

RESIDENTIAL TRIM INDEX

<u>DWG #:</u>	<u>DESCRIPTION:</u>	<u>IMAGE #:</u>
RSTW-0001	Residential Ridge Flashing	72
RSTW-0002	Hip Cap	69
RSTW-0003	High Side Eave Trim	9
RSTW-0004	High Side Tie-In Trim	14
RSTW-0005	Rake Trim	51
RSTW-0006	Valley Trim	30
RSTW-0007	Gutter	118
RSTW-0008	Rake Tie-In	64
RSTW-0009	Gutter Strap	123
RSTW-0010	5V - Crimp Panel Cap	284
RSTW-0011	Gutter End Cap	121
RSTW-0012	Ridge Cap (R-RC-13)	76
RSTW-0013	Eave Trim	22
RSTW-0014	Max-Rib / Mesa Panel Cap	285
RSTW-0015	D-Edge Trim	54

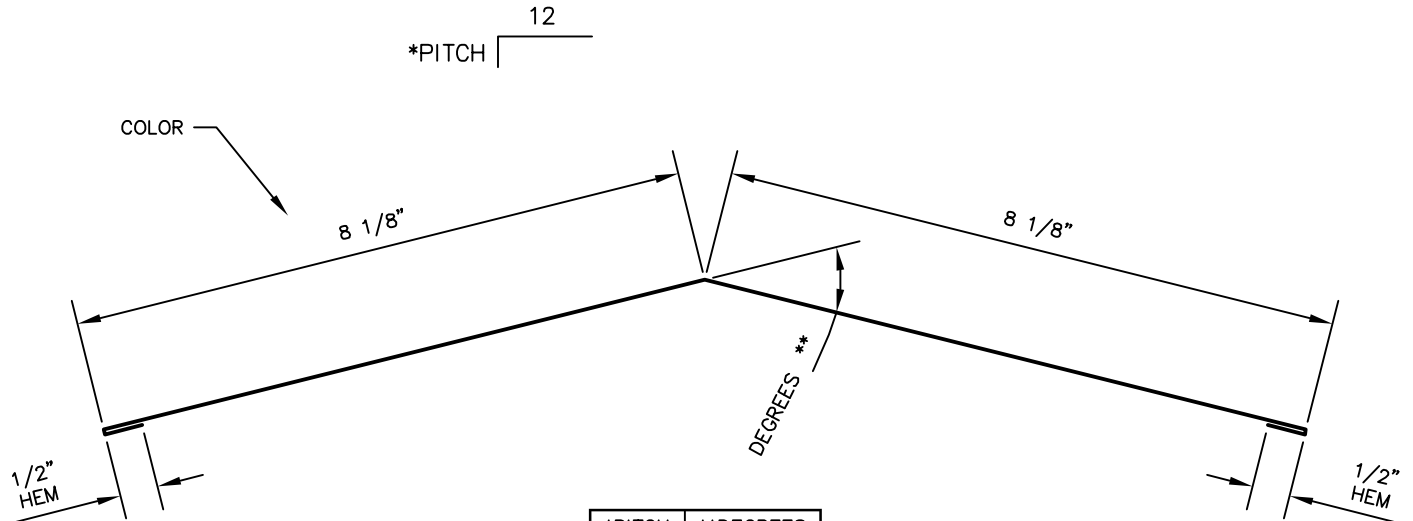

*PITCH	**DEGREES
1:12	10°
2:12	19°
3:12	28°
4:12	37°
5:12	45°
6:12	53°
7:12	61°
8:12	68°
9:12	74°
10:12	80°
11:12	85°
12:12	90°

RESIDENTIAL RIDGE FLASHING

PANEL PROFILES	GAUGE
MAX-RIB	26 or 29
MESA	26 or 29
5V-CRIMP	26 or 29

7-28-15 rev.
 6-04-13 rev.
 7-20-11 rev.
 9-12-96

GIRTH: 17 1/4"
 BENDS: 90° AND AS SPECIFIED

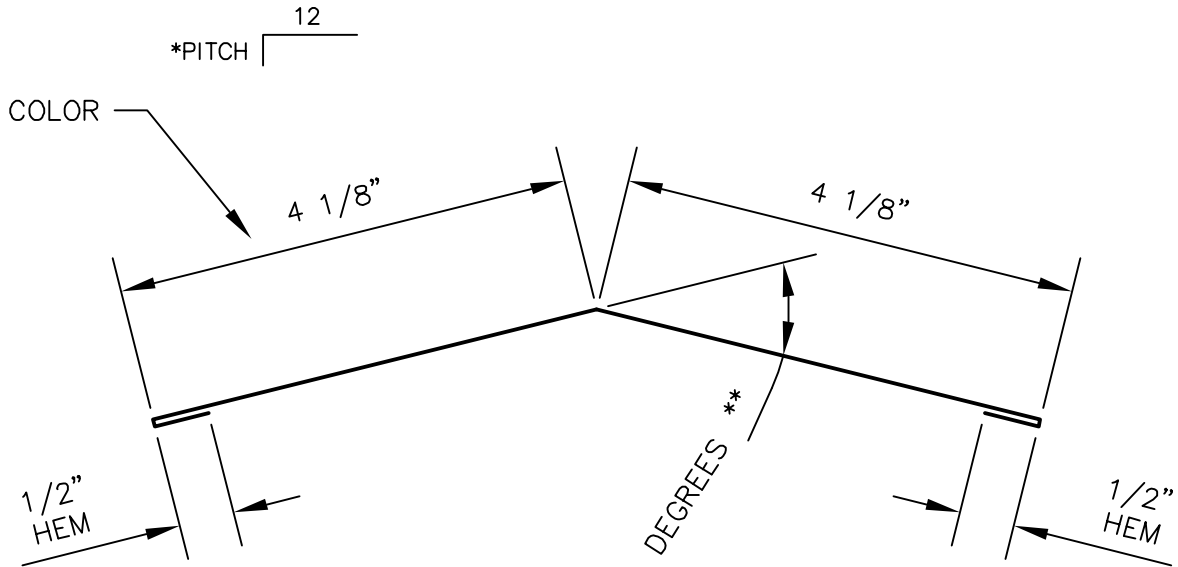

HIP TRIM	
*PITCH	**DEGREES
1:12	7°
2:12	14°
3:12	20°
4:12	27°
5:12	33°
6:12	39°
7:12	45°
8:12	51°
9:12	57°
10:12	63°
11:12	69°
12:12	75°

HIP CAP

PANEL PROFILES	GAUGE
MAX-RIB	26 or 29
MESA	26 or 29
MERIDIAN	26
U PANEL	26 or 29
5V-CRIMP	26 or 29

7-28-15 rev.
 6-04-13 rev.
 7-20-11 rev.
 9-12-96

GIRTH: 9 1/4"
 BENDS: 90° AND AS SPECIFIED



* PITCH $\left| \begin{array}{l} 12 \\ \hline \end{array} \right.$

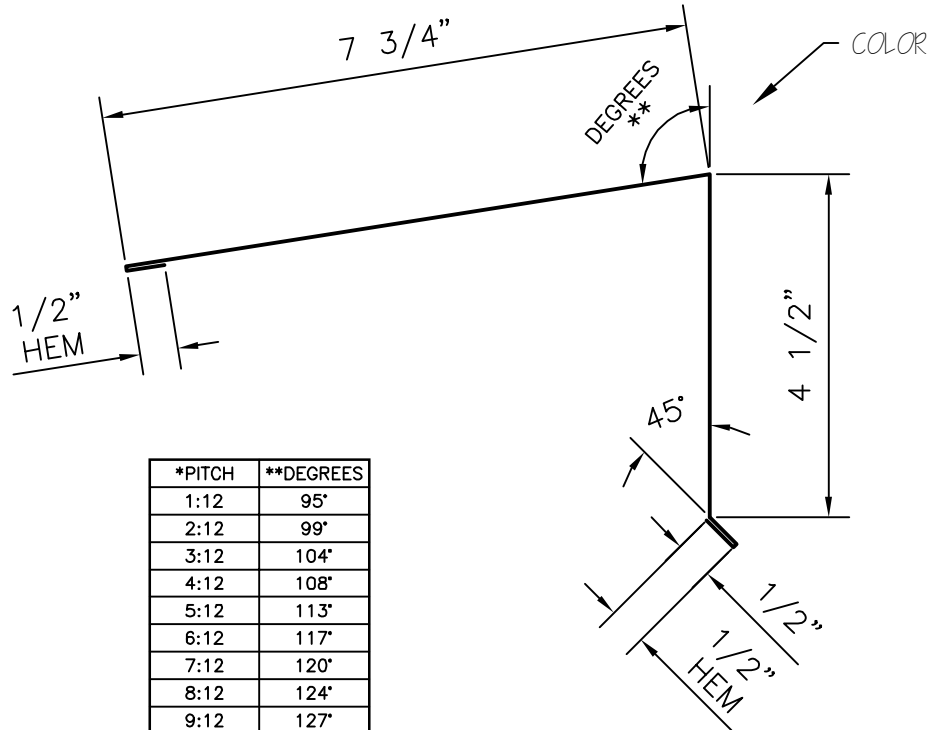

*PITCH	**DEGREES
1:12	95°
2:12	99°
3:12	104°
4:12	108°
5:12	113°
6:12	117°
7:12	120°
8:12	124°
9:12	127°
10:12	130°
11:12	133°
12:12	135°

HIGH SIDE EAVE TRIM

PANEL PROFILES	GAUGE
MAX-RIB	26 or 29
MESA	26 or 29
MERIDIAN (EF)	26
5V-CRIMP	26 or 29

7-28-15 rev.
 8-25-13 rev.
 4-29-11

GIRTH: 13 3/4"
 BENDS: AS SPECIFIED



12 * PITCH

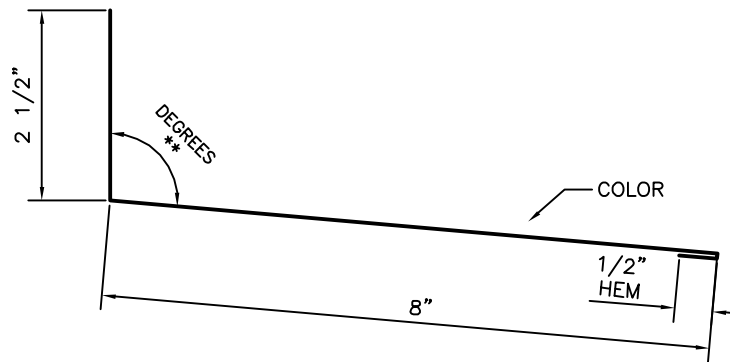

* USE 3:12 UNLESS NOTED

* PITCH	IN DEGREES
1:12	95°
2:12	99°
3:12	104°
4:12	108°
5:12	113°
6:12	117°
7:12	120°
8:12	124°
9:12	127°
10:12	130°
11:12	133°
12:12	135°

HIGH-SIDE TIE-IN TRIM

PANEL PROFILES	GAUGE
MAX-RIB	26 or 29
MESA	26 or 29
MERIDIAN	26
5V-CRIMP	26 or 29

7-28-15 rev.
 6-04-13 rev.
 4-29-11

GIRTH: 11"
 BENDS: AS SPECIFIED

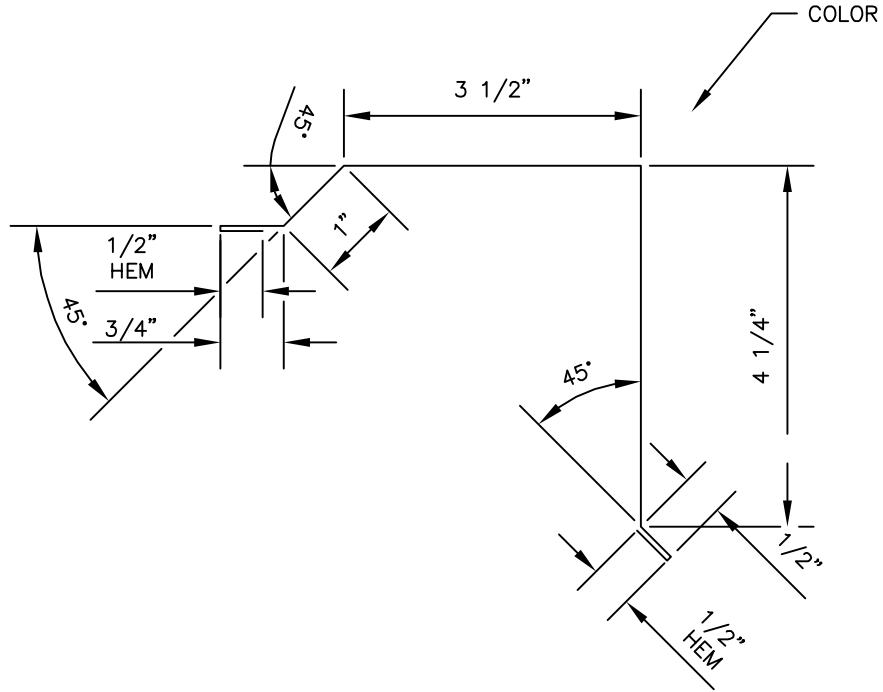

RAKE TRIM

PANEL PROFILES	GAUGE
MAX-RIB	26 or 29
MESA	26 or 29
5V-CRIMP	26 or 29

7-28-15 rev.
 6-04-13 rev.
 6-20-11

GIRTH: 11"
 BENDS: 90° AND AS SPECIFIED

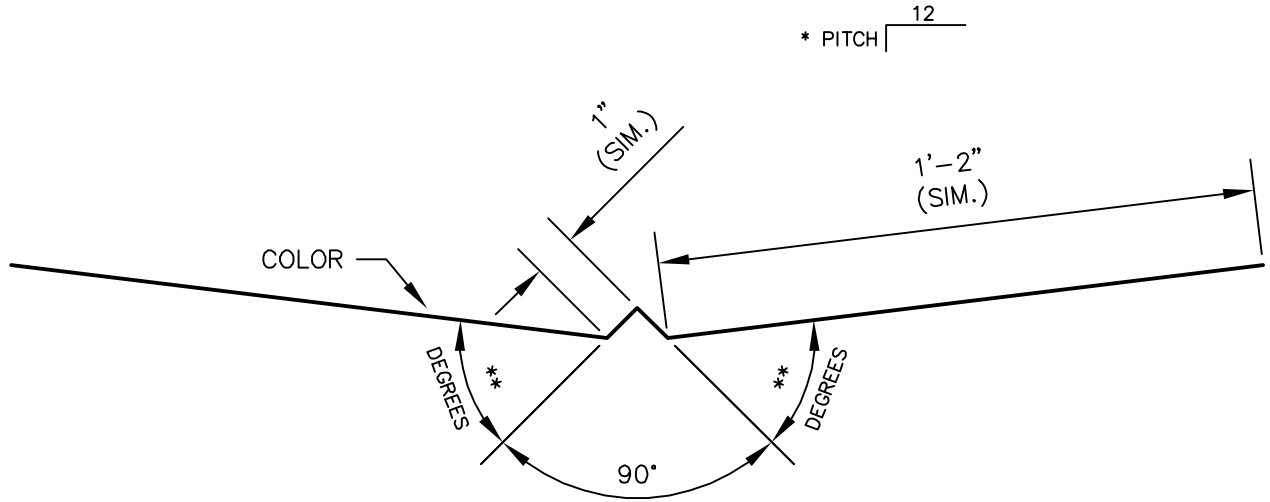

* PITCH	**DEGREES
1:12	48°
2:12	52°
3:12	55°
4:12	58°
5:12	61°
6:12	64°
7:12	68°
8:12	70°
9:12	73°
10:12	76°
11:12	79°
12:12	82°

VALLEY TRIM

PANEL PROFILES	GAUGE
MAX-RIB	26 or 29
MESA	26 or 29
5V-CRIMP	26 or 29

7-28-15 rev.
 8-26-13 rev.
 7-20-11 rev.
 9-12-96

GIRTH: 30"
 BENDS: 90° AND AS SPECIFIED

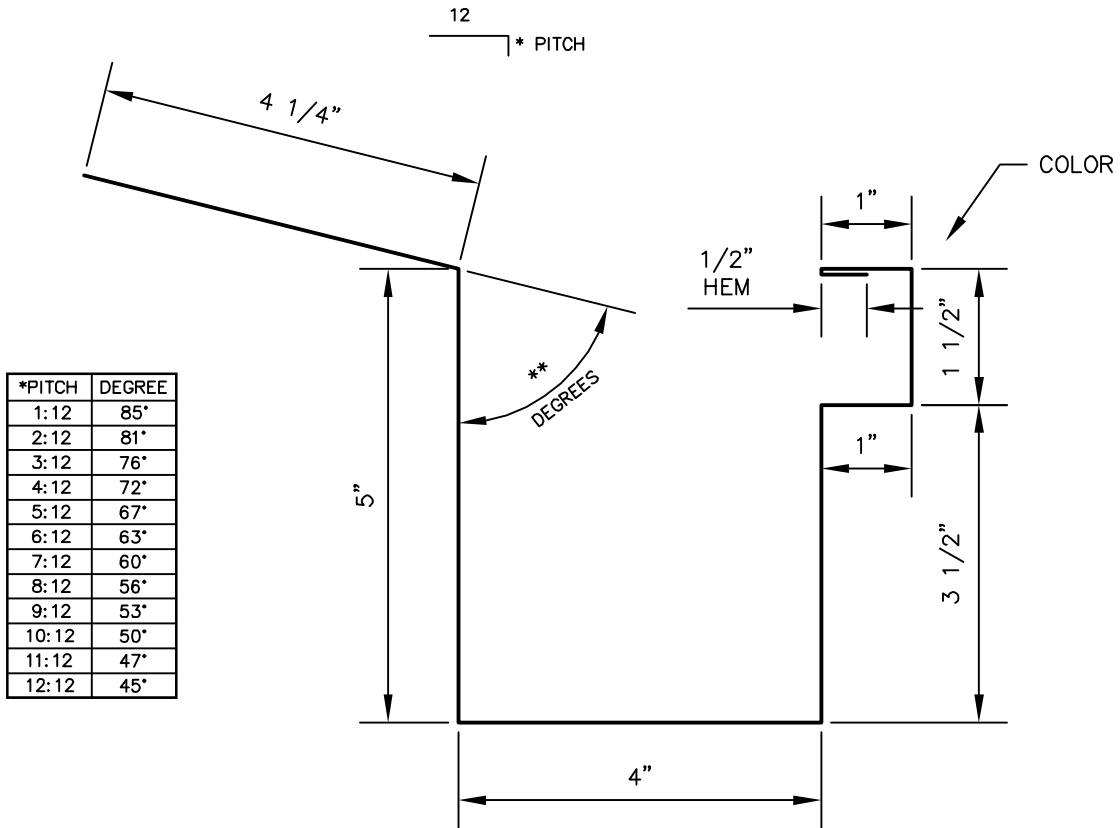

GUTTER

PANEL PROFILES	GAUGE
MAX-RIB	26 or 29
MESA	26 or 29
M-COR	26 or 29
MULTI-COR	26 or 29
U-PANEL	26 or 29
5V-CRIMP	26 or 29

7-28-15 rev.
 6-04-13 rev.
 9-27-11 rev.
 9-12-96

GIRTH: 20 3/4"
 BENDS: 90° AND AS SPECIFIED

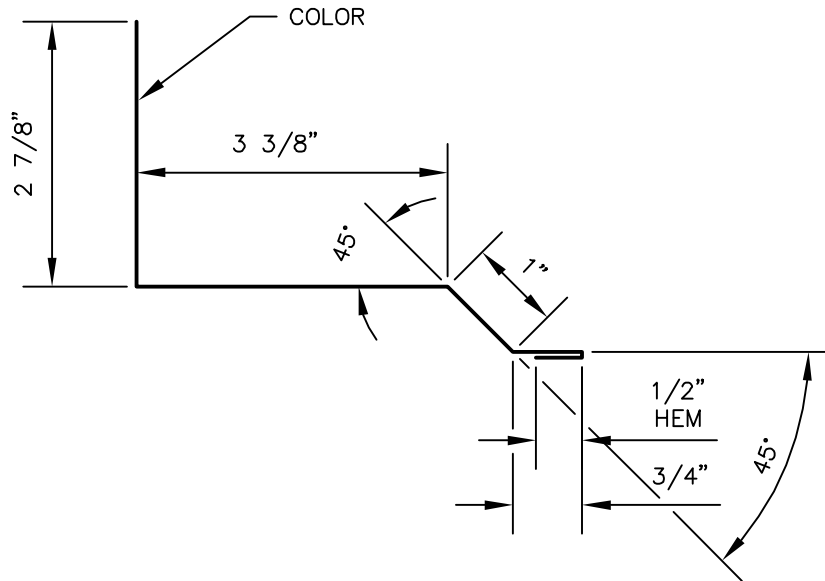

RAKE TIE-IN TRIM

PANEL PROFILES	GAUGE
MAX-RIB	26 or 29
MESA	26 or 29
5V-CRIMP	26 or 29

7-28-15 rev.
6-04-13 rev.
6-20-11 rev.
9-12-96

GIRTH: 8 1/2"
BENDS: 90° AND AS SPECIFIED

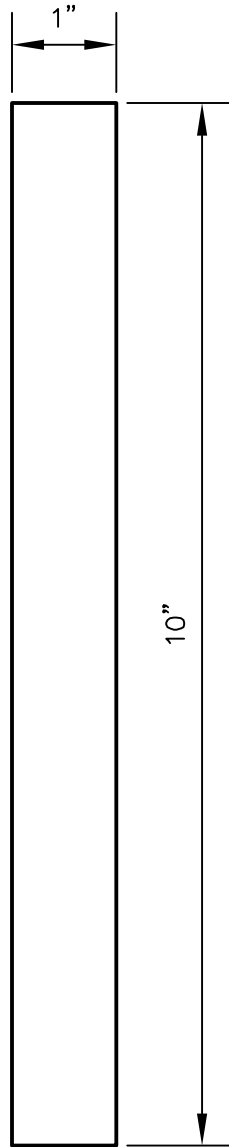

GUTTER STRAP

PANEL PROFILES	GAUGE
ALL PANELS	24, 26 or 29

7-28-15 rev.
9-27-11 rev.
9-12-96

GIRTH: 1" X 10"
BENDS: NONE

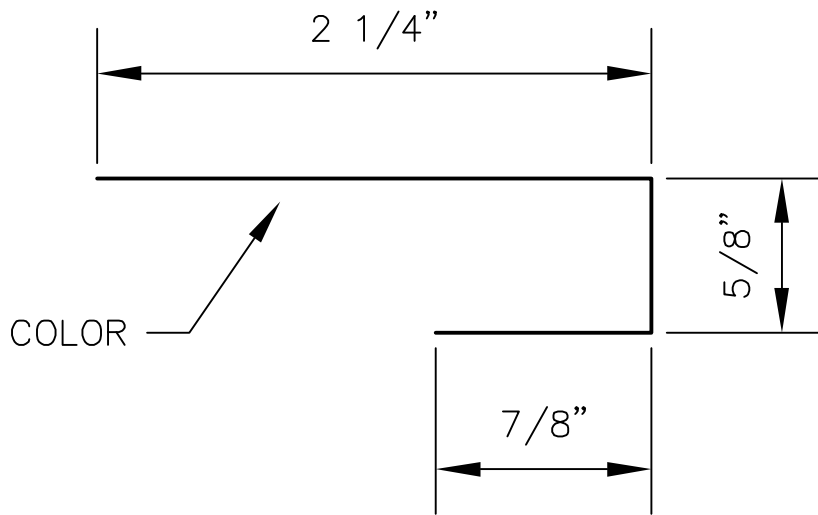

5V-CRIMP PANEL CAP TRIM

PANEL PROFILES	GAUGE
5V-CRIMP	26 or 29
MINI-RIB	26 or 29

3-18-20 rev.
7-28-15 rev.
8-06-08 rev.
11-16-04

GIRTH: 3 3/4"
BENDS: 90° AND AS SPECIFIED

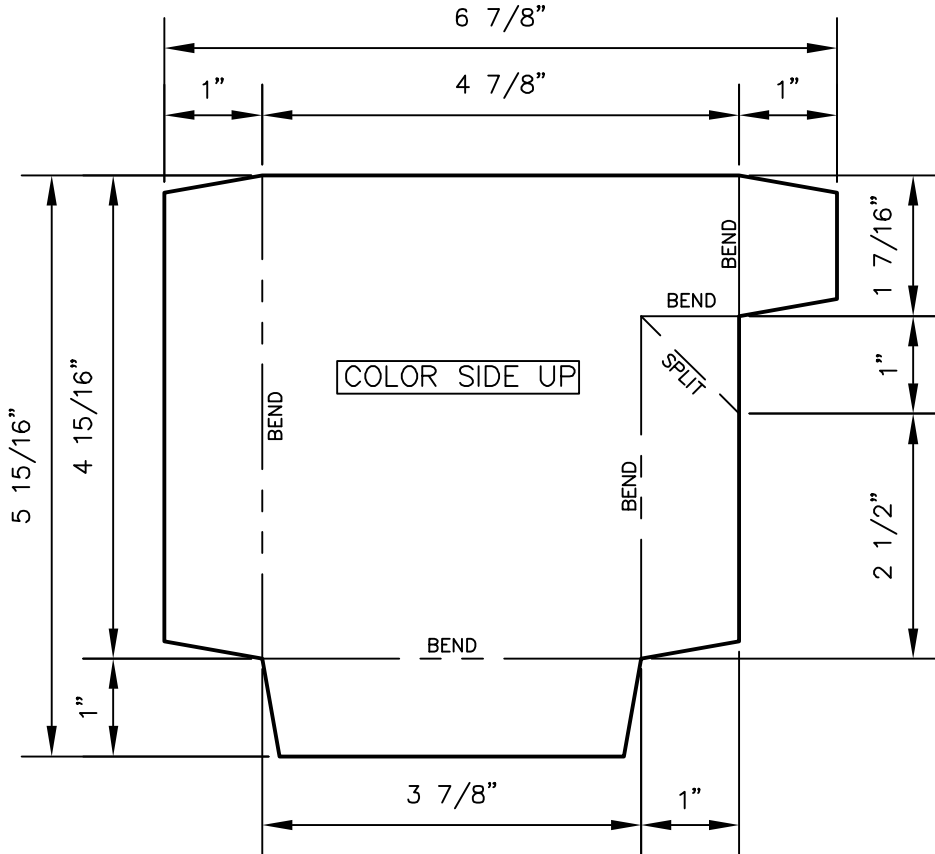
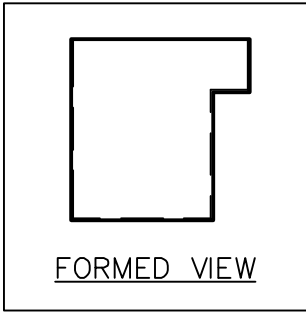

PANEL PROFILES	GAUGE
MAXIMA 1.5"	24
MAXIMA 2"	24
MAXIMA 3"	24
MAXIMA ADV	24
MEDALLION I	24
MEDALLION II	24
MEDALLION-LOK	24
MERIDIAN	26
MAX-RIB	26 or 29
MESA	26 or 29
5V-CRIMP	26 or 29

GUTTER END CAP

(L.H. SHOWN - R.H. OPP.)

7-28-15 rev.
 6-04-13 rev.
 9-27-11 rev.
 9-12-96

GIRTH: 5 15/16" X 6 7/8"
 BENDS: 90° AND AS SPECIFIED

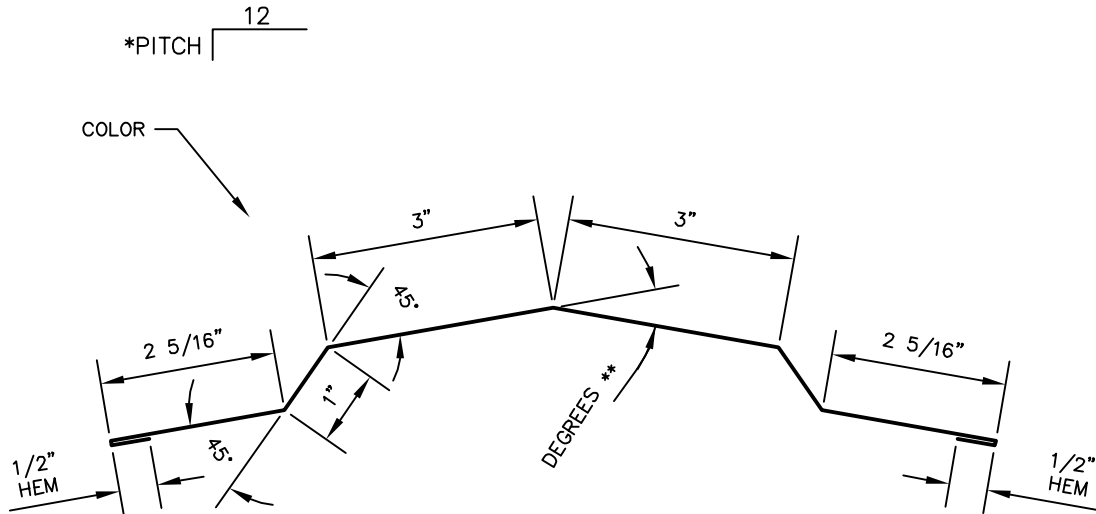

*PITCH	**DEGREES
1:12	10°
2:12	19°
3:12	28°
4:12	37°
5:12	45°
6:12	53°
7:12	61°
8:12	68°
9:12	74°
10:12	80°
11:12	85°
12:12	90°

RIDGE CAP

(R-RC-13)

PANEL PROFILES	GAUGE
MAX-RIB	26 or 29
MESA	26 or 29
5V-CRIMP	26 or 29

7-28-15 rev.
 2-14-14 rev.
 6-04-13 rev.
 7-20-11 rev.
 5-07-95

GIRTH: 13 5/8"
 BENDS: 90° AND AS SPECIFIED

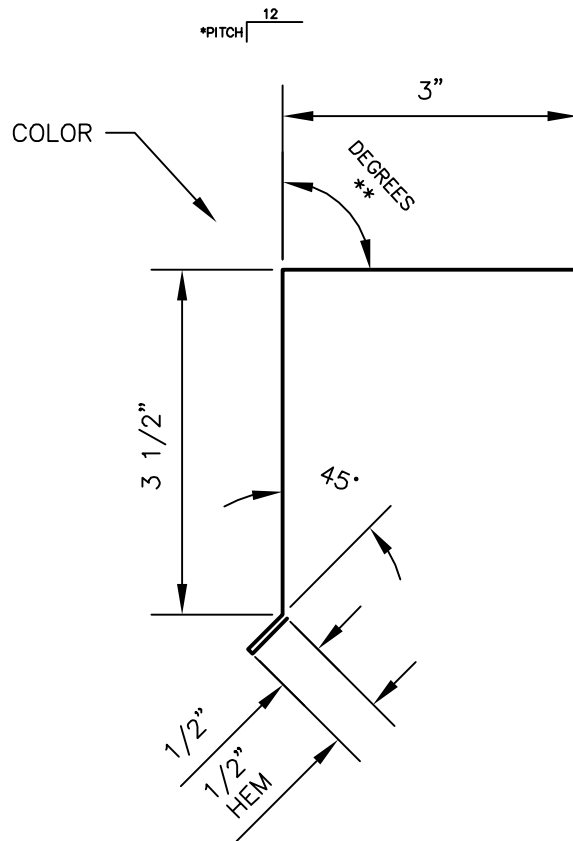

*PITCH	**DEGREES
0:12	90°
1:12	85°
2:12	81°
3:12	76°
4:12	72°
5:12	67°
6:12	63°
7:12	60°
8:12	56°
9:12	53°
10:12	50°
11:12	47°
12:12	45°

EAVE TRIM

PANEL PROFILES	GAUGE
MULTI-RIB	26 or 29
R-PANEL	26 or 29
MULTI-COR	26 or 29
M-COR	26 or 29
U-PANEL	26 or 29
MAX-RIB	26 or 29
MESA	26 or 29
5V-CRIMP	26 or 29

7-28-15 rev.
 6-04-13 rev.
 6-20-11

GIRTH: 7 1/2"
 BENDS: 90° AND AS SPECIFIED

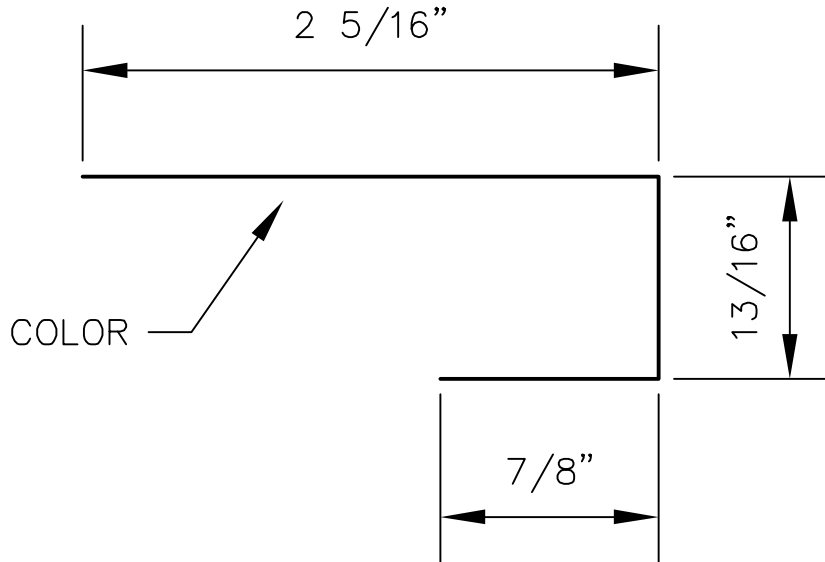

PANEL CAP TRIM
(FOR MAX-RIB OR MESA)

PANEL PROFILES	GAUGE
MAX-RIB	26 or 29
MESA	26 or 29

7-28-15 rev.
10-12-11 rev.
11-16-04

GIRTH: 4"
BENDS: 90° AND AS SPECIFIED

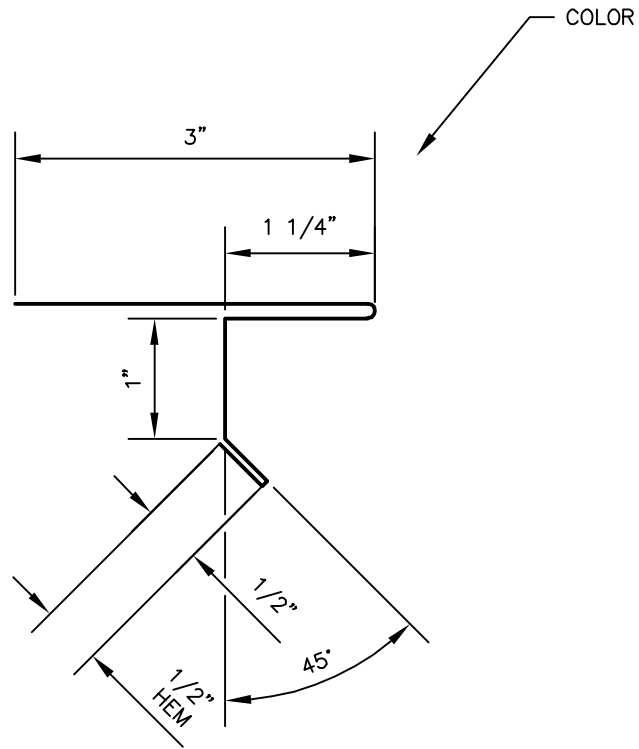

D-EDGE TRIM
 (FOR USE AT RAKES ONLY)

PANEL PROFILES	GAUGE
MAX-RIB	26 or 29
MESA	26 or 29
5V-CRIMP	26 or 29

- 5-21-19 rev.
- 2-20-18 rev.
- 5-11-16 rev.
- 7-28-15 rev.
- 6-20-11

GIRTH: 6 1/4"
 BENDS: 90° AND AS SPECIFIED