

# MAXIMA TRIM INDEX

<u>DWG #:</u>	<u>DESCRIPTION:</u>	<u>IMAGE #:</u>
MXTW-0101	Sculptured Eave Trim - 2" Panel Only	36
MXTW-0102	Rake Trim	44
MXTW-0103	Gutter - up to 2:12 (2" Maxima Panel only)	89
MXTW-0104	Gutter End Cap - up to 2:12 (1.5" & 2" Maxima Panel only) Pattern	105B
MXTW-0104A	Gutter End Cap - up to 2:12 (1.5" & 2" Maxima Panel only) Finished	105A
MXTW-0105	Gutter - 2:12 to 4:12 (2" Maxima Panel only)	95
MXTW-0106	Gutter End Cap -2:12 to 4:12 (1.5" & 2" Maxima Panel only) Pattern	110B
MXTW-0106A	Gutter End Cap -2:12 to 4:12 (1.5" & 2" Maxima Panel only) Finished	110A
MXTW-0107	Valley Trim	30
MXTW-0108	Hip Trim	70
MXTW-0109	2" Zee Flashing (2" Maxima Panel only)	135
MXTW-0110	Fixed High-Side Tie-In Trim	12
MXTW-0113	Floating High-Side Tie-In Trim	16
MXTW-0114	Rake Tie-In Trim	58
MXTW-0115	Gutter - up to 2:12 (3" Maxima Panel only)	94
MXTW-0116	Sculptured Eave Trim (3" Maxima Panel only)	35
MXTW-0122	Cinch Angle	210
MXTW-0123	Gutter Strap	117
MXTW-0124	Fixed Ridge Trim - up to 4:12	73
MXTW-0126	Floating Ridge Trim - up to 4:12	81
MXTW-0128	Zee Closure (3" Maxima Panel only)	136
MXTW-0129	Rake End Closure (Pattern)	191B
MXTW-0130	Rake End Closure (Finished)	191A
MXTW-0131	High Side Eave Trim - up to 2:12	1
MXTW-0132	Rake Slide	55
MXTW-0133	Gutter End Cap - up to 2:12 (3" Maxima Panel only) - Pattern	106B
MXTW-0134	Gutter End Cap - up to 2:12 (3" Maxima Panel only) - Finished	106A
MXTW-0135	Gutter - 2:12 to 4:12 (3" Maxima Panel only)	94
MXTW-0136	Gutter End Cap - 2:12 to 4:12 (3" Maxima Panel only) - Finish	109A
MXTW-0137	Gutter End Cap - 2:12 to 4:12 (3" Maxima Panel only) - Pattern	109B
MXTW-0138	High Side Eave Trim - 2:12 to 4:12	2
MXTW-0139	Simple Eave Trim	20
MXTW-0140	Peak Box - 2:12 to 4:12 - Pattern	241B
MXTW-0141	Peak Box - 2:12 to 4:12 - Finished	241A
MXTW-0142	Peak Box - up to 2:12 - Pattern	239B
MXTW-0143	Peak Box - up to 2:12 - Finished	239A

<u>DWG #:</u>	<u>DESCRIPTION:</u>	<u>IMAGE #:</u>
MXTW-0144	Floating Peak Box - up to 2:12 - Finished	243A
MXTW-0145	Floating Peak Box - Pattern "A" - up to 2:12	243B
MXTW-0146	Floating Peak Box - Pattern "B" - up to 2:12	243C
MXTW-0147	Floating Peak Box - 2:12 to 4:12 - Finished	246A
MXTW-0148	Floating Peak Box - Pattern "A" 2:12 to 4:12	246B
MXTW-0149	Floating Peak Box - Pattern "B" 2:12 to 4:12	246C
MXTW-0160	Gutter for 6:12 (2" Maxima Panel only)	92
MXTW-0161	Gutter End Cap for 6:12 (2" Maxima Panel only) - Pattern	111B
MXTW-0161A	Gutter End Cap for 6:12 (2" Maxima Panel only) - Finished	111A
MXTW-0165	Floating Hip Trim	75
MXTW-0166	Zee Closure (1.5" Maxima Panel only)	132
MXTW-0167	Sculptured Eave Trim (1.5" Maxima Panel only)	37
MXTW-0168	Gutter - up to 2:12 (1.5" Maxima Panel only)	90
MXTW-0169	Gutter - 2:12 to 4:12 (1.5" Maxima Panel only)	96
MXTW-0170	Angle Trim	144
MXTW-0171	Outside Corner Box for Standard Gutter - Finished	193A
MXTW-0172	Outside Corner Box for Standard Gutter - Rake Pattern	193B
MXTW-0173	Outside Corner Box for Standard Gutter - Eave Pattern	193C
MXTW-0174	High Side Corner Box - Finished	204A
MXTW-0175	High Side Corner Box - Rake Pattern	204B
MXTW-0176	High Side Corner Box - Eave Pattern	204C
MXTW-0177	Gutter Corner Box for Sculptured Eave - Finished	200A
MXTW-0178	Gutter Corner Box for Sculptured Eave - Patterns	200B
		200C
		200D
MXTW-0179	Gutter Corner Box for Standard Gutter - Finished	196A
MXTW-0180	Gutter Corner Box for Standard Gutter - Patterns	196B
		196C
		196D

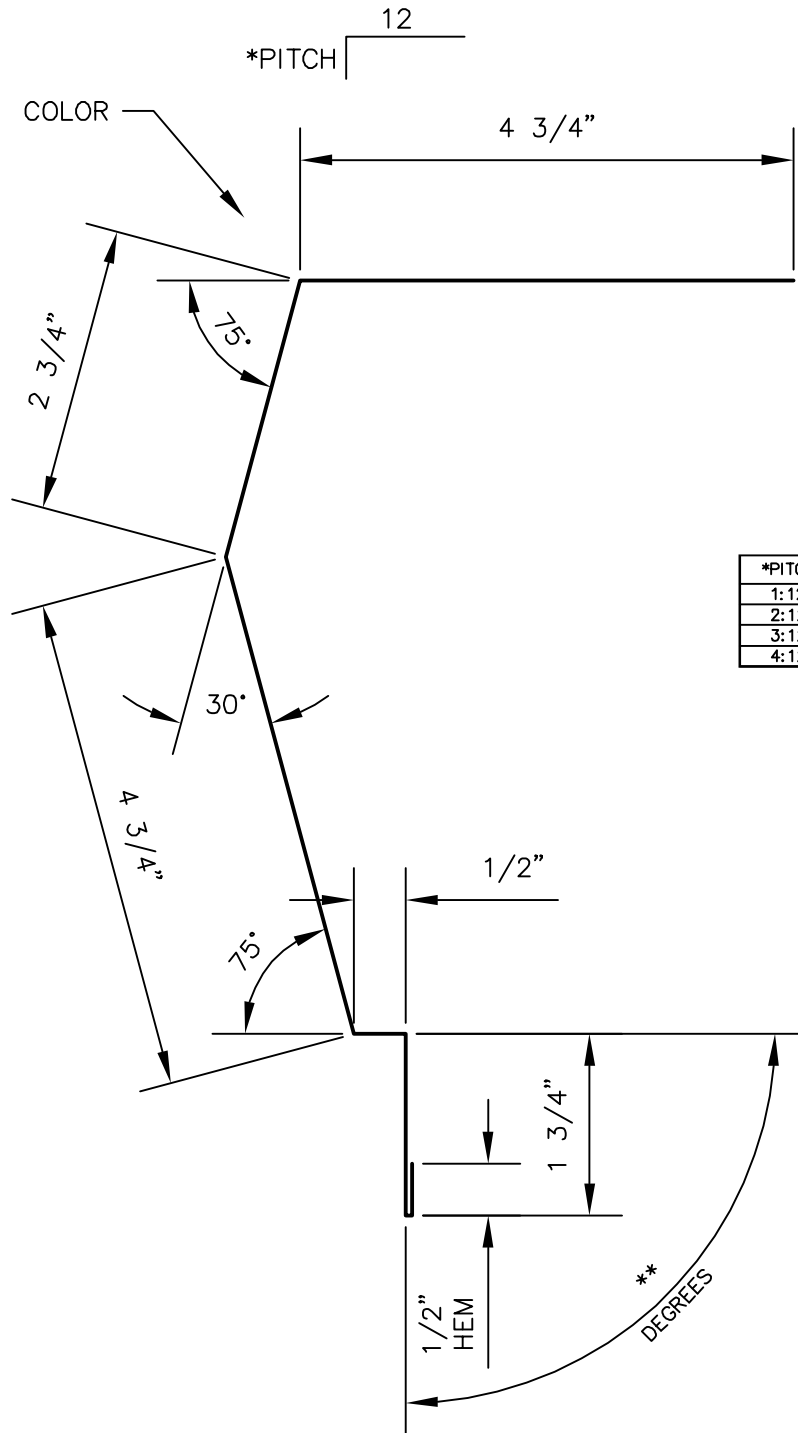

*PITCH	**DEGREES
1:12	95°
2:12	99°
3:12	103°
4:12	108°

### SCULPTURED EAVE TRIM

PANEL PROFILES	GAUGE
MAXIMA 2"	24
MAXIMA ADV	24

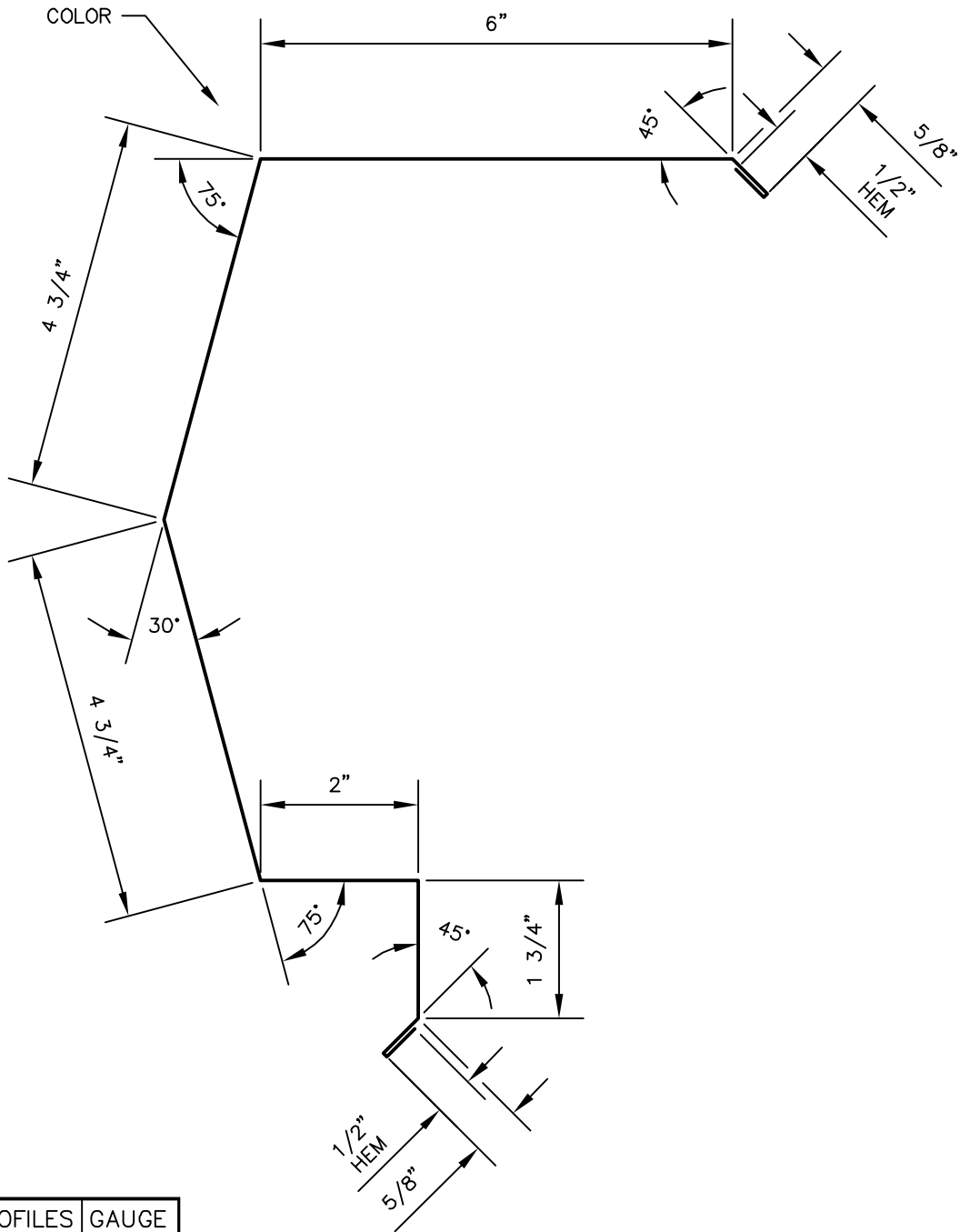

PANEL PROFILES	GAUGE
MAXIMA 1.5"	24
MAXIMA 2"	24
MAXIMA 3"	24
MAXIMA ADV	24

RAKE TRIM

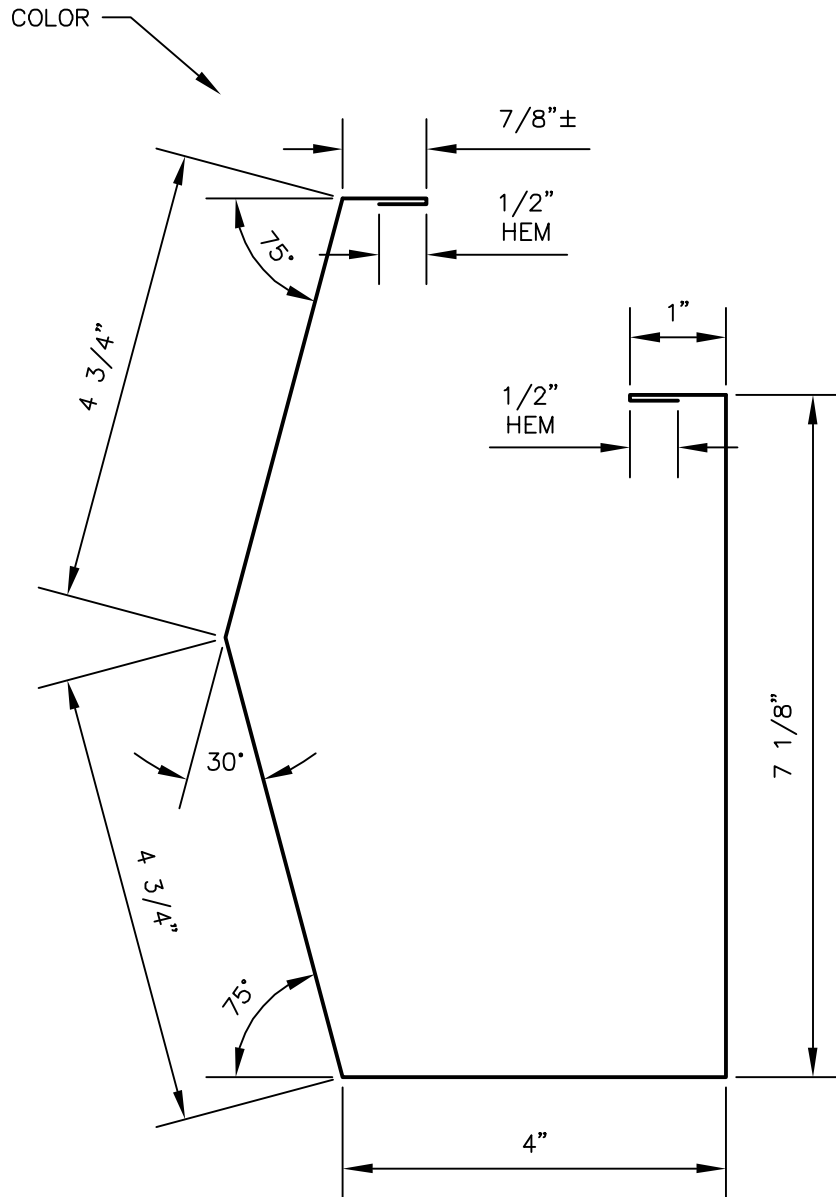

### GUTTER (FOR UP TO 2:12)

(FOR 2" MAXIMA PANEL ONLY)

PANEL PROFILES	GAUGE
MAXIMA 2"	24
MAXIMA ADV	24

7-01-13 rev.  
 9-27-11 rev.  
 9-18-97

GIRTH:  $23 \frac{1}{2}"$   
 BENDS:  $90^\circ$  UNLESS NOTED

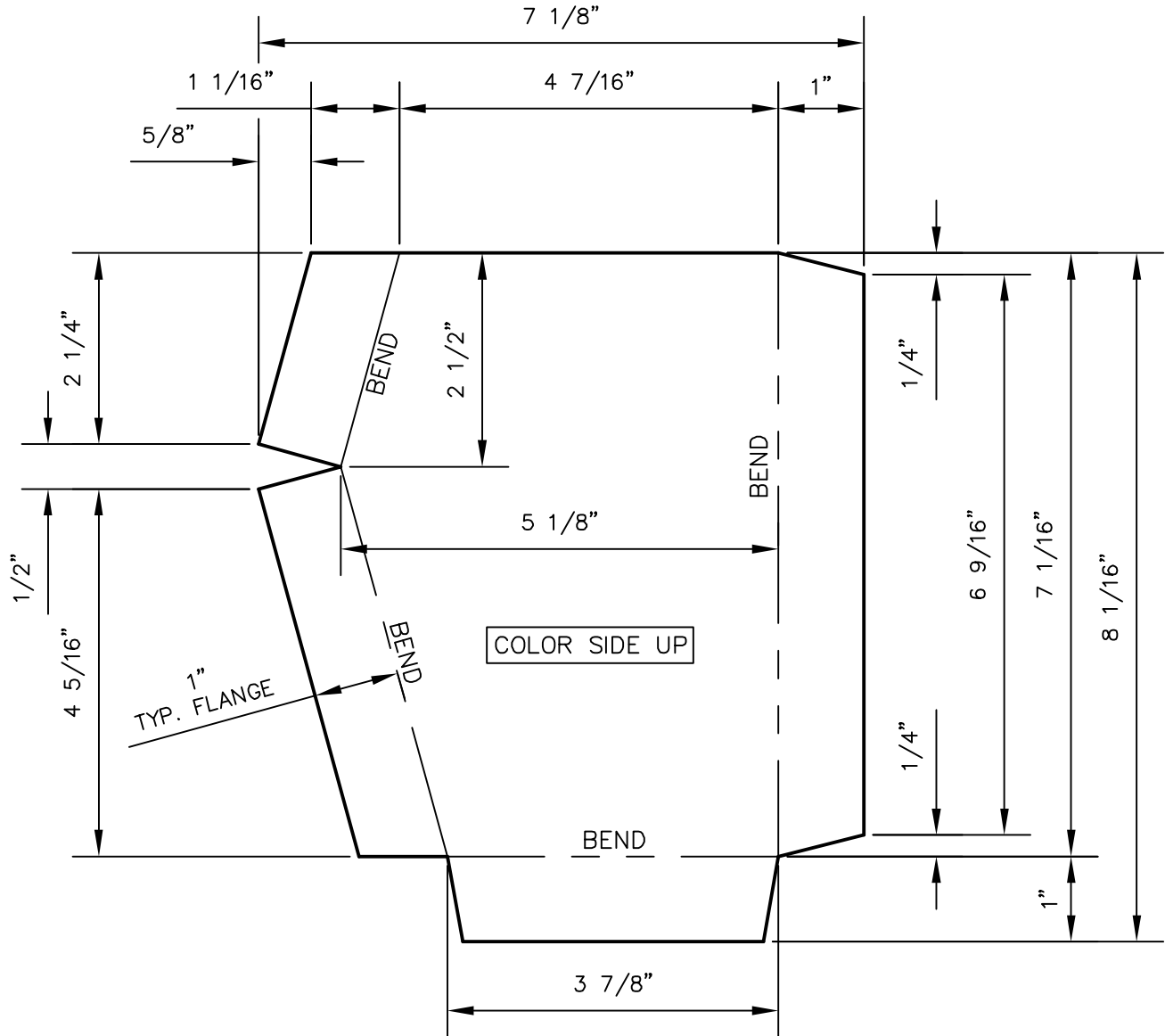

## GUTTER END CAP (UP TO 2:12) - PATTERN

(RIGHT HAND SHOWN - LEFT HAND OPPOSITE)

(FOR MAXIMA 1.5" & 2" PANELS ONLY)

PANEL PROFILES	GAUGE
MAXIMA 1.5"	24 or 26
MAXIMA 2"	24 or 26
MAXIMA ADV	24 or 26

5-19-16 rev.  
 8-22-13 rev.  
 9-27-11 rev.  
 1-20-98 rev.  
 1-03-94

GIRTH: 7 1/8" X 8 1/16"  
 BENDS: DOWN 90°  
 FINISHED DETAIL: MXTW-0104A

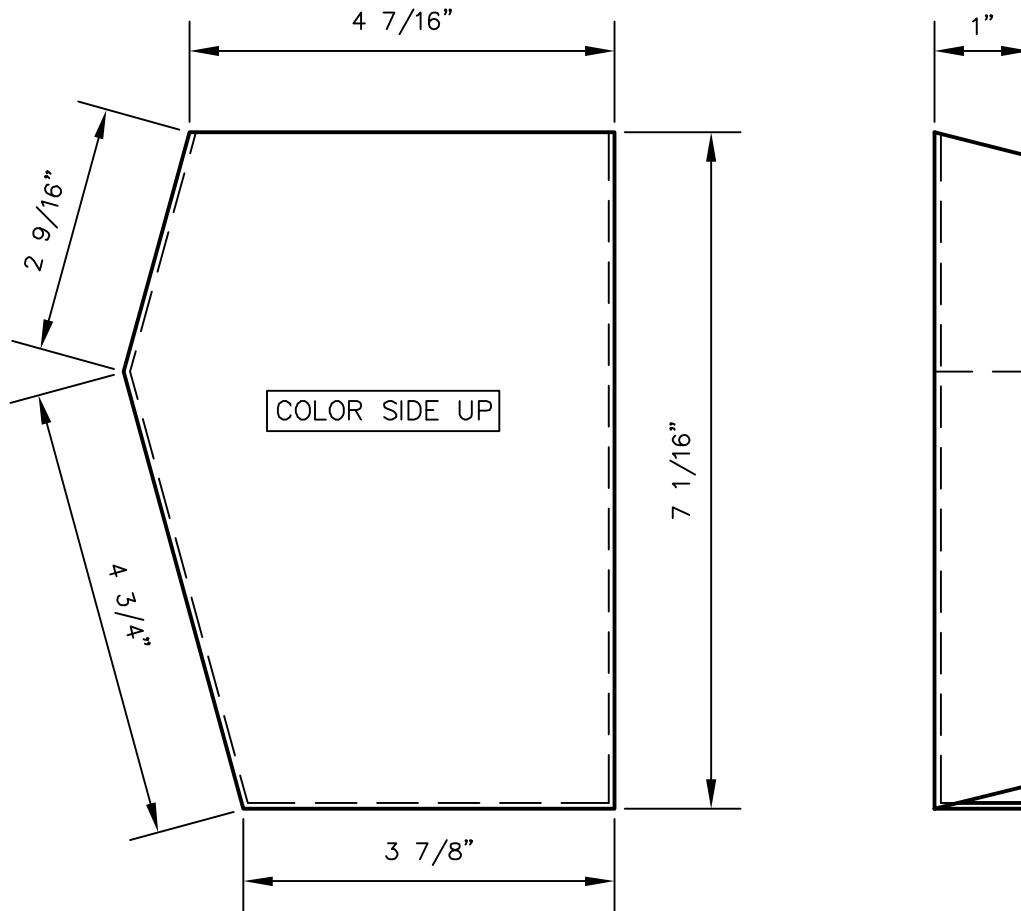

### GUTTER END CAP (UP TO 2:12) - FINISHED

(RIGHT HAND SHOWN – LEFT HAND OPPOSITE)

(FOR MAXIMA 1.5" & 2" PANELS ONLY)

PANEL PROFILES	GAUGE
MAXIMA 1.5"	24 or 26
MAXIMA 2"	24 or 26
MAXIMA ADV	24 or 26

5-19-16 rev.  
 8-22-13 rev.  
 9-27-11 rev.  
 12-24-97

GIRTH: SEE PATTERN MXTW-0104  
 BENDS: SEE PATTERN MXTW-0104

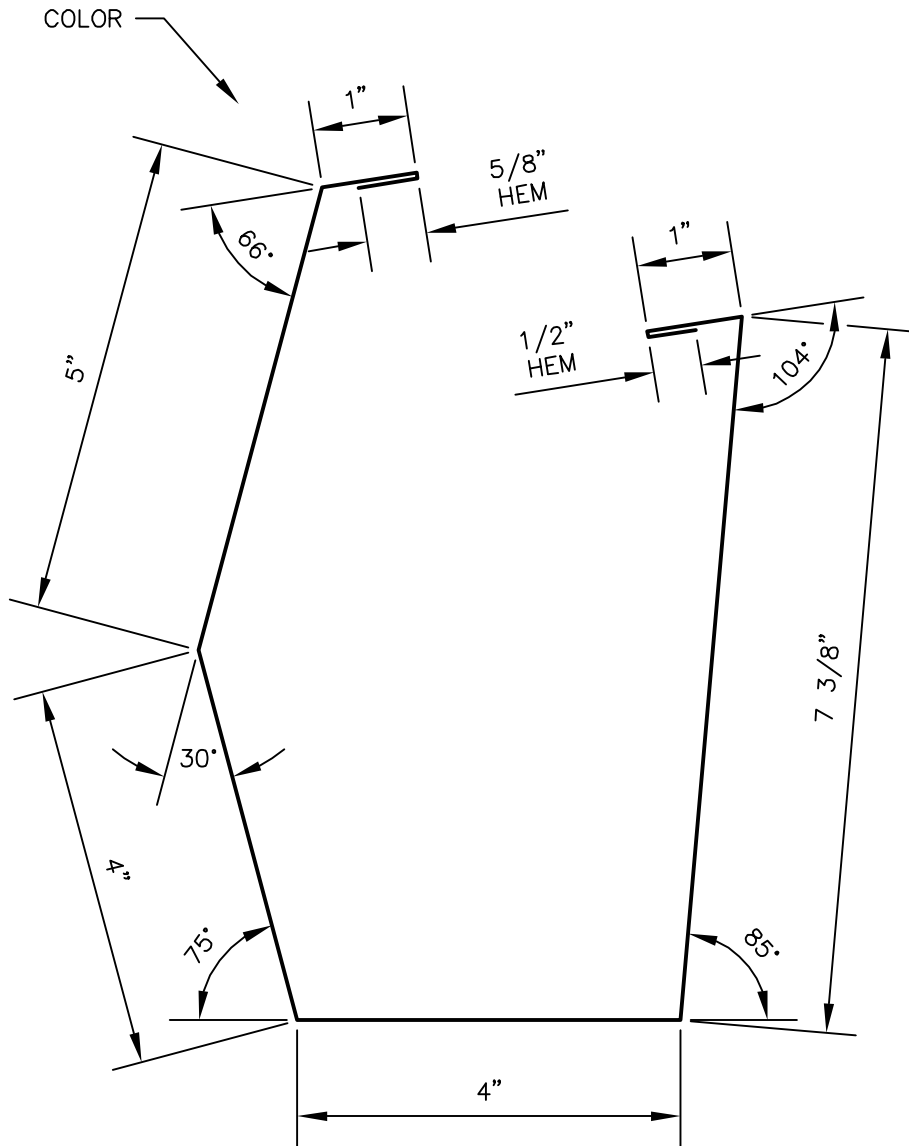

**GUTTER (2:12 TO 4:12)**

(RIGHT HAND SHOWN – LEFT HAND OPPOSITE)

(FOR MAXIMA 2" PANEL ONLY)

PANEL PROFILES	GAUGE
MAXIMA 2"	24
MAXIMA ADV	24

7-01-13 rev.  
 9-27-11 rev.  
 4-15-03 rev.  
 6-18-98 rev.  
 9-18-97

GIRTH: 23 1/2"  
 BENDS: 90° AND AS NOTED



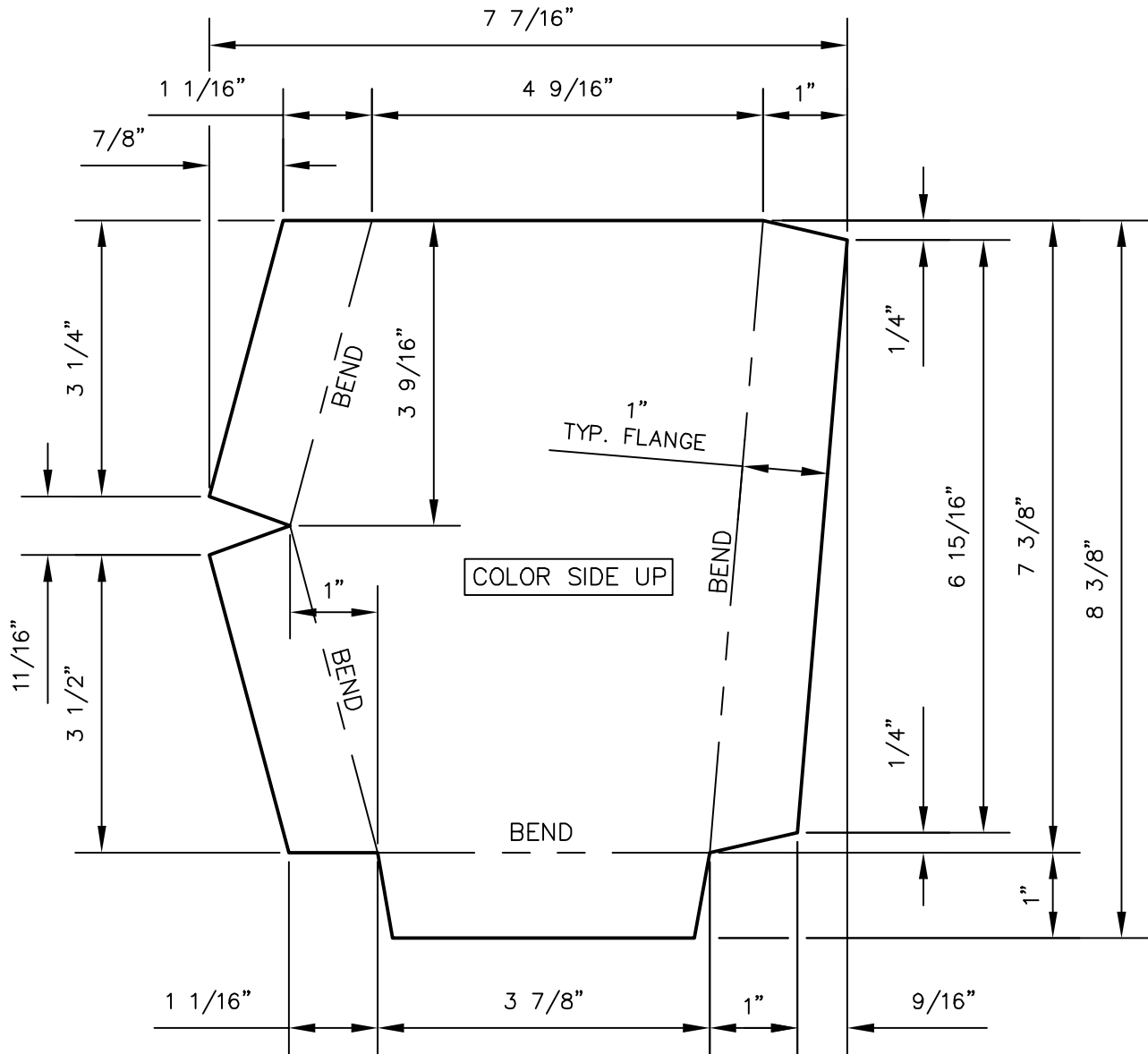

### GUTTER END CAP (2:12 TO 4:12) - PATTERN

(RIGHT HAND SHOWN - LEFT HAND OPPOSITE)  
 (FOR MAXIMA 1.5" & 2" PANELS ONLY)

PANEL PROFILES	GAUGE
MAXIMA 1.5"	24 or 26
MAXIMA 2"	24 or 26
MAXIMA ADV	24 or 26

5-19-16 rev.  
 8-22-13 rev.  
 9-27-11 rev.  
 9-18-97

GIRTH:  $7 \frac{7}{16}$ " X  $8 \frac{3}{8}$ "  
 BENDS: DOWN 90°  
 FINISHED DETAIL: MXTW-0106A

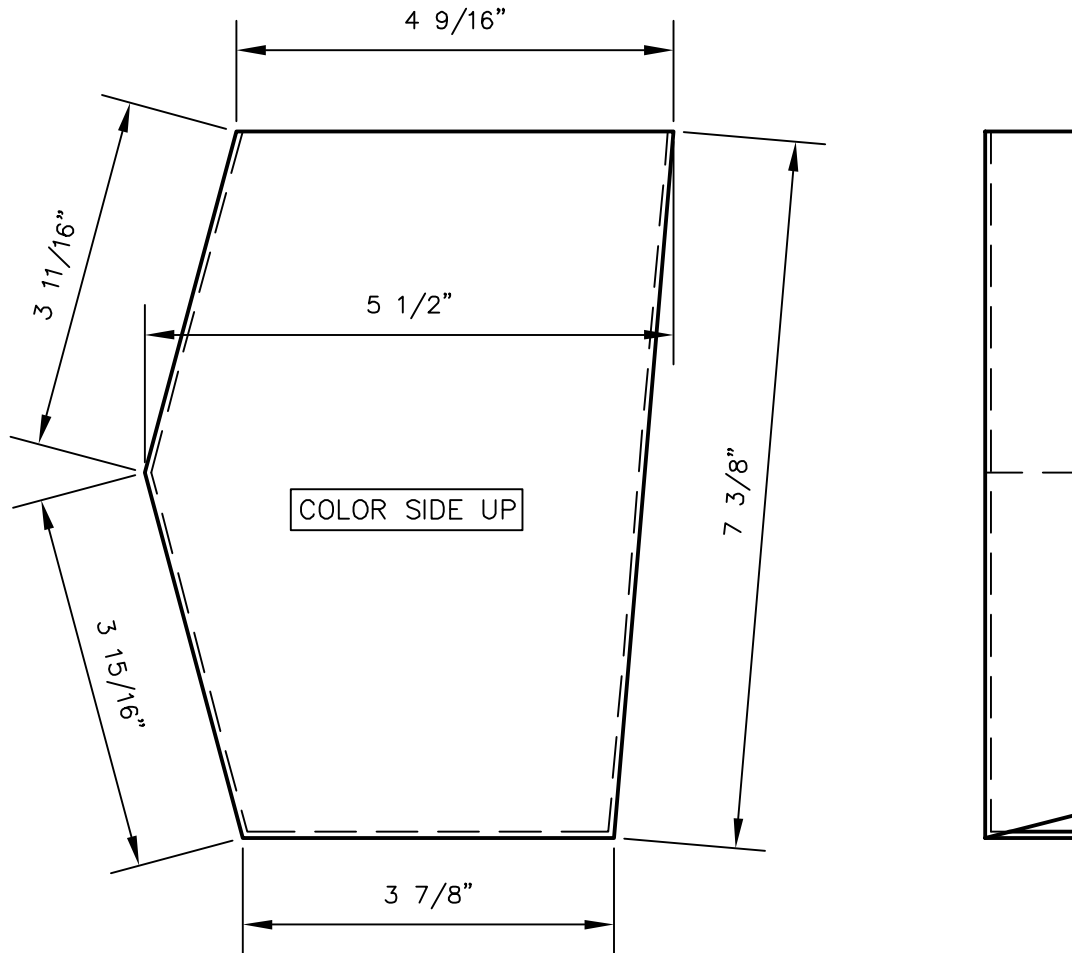

## GUTTER END CAP (2:12 TO 4:12) - FINISHED

(RIGHT HAND SHOWN – LEFT HAND OPPOSITE)  
 (FOR MAXIMA 1.5" & 2" PANELS ONLY 2:12 TO 4:12)

PANEL PROFILES	GAUGE
MAXIMA 1.5"	24 or 26
MAXIMA 2"	24 or 26
MAXIMA ADV	24 or 26

5-19-16 rev.  
 8-22-13 rev.  
 9-27-11 rev.  
 12-23-97

GIRTH: SEE PATTERN MXTW-0106  
 BENDS: SEE PATTERN MXTW-0106

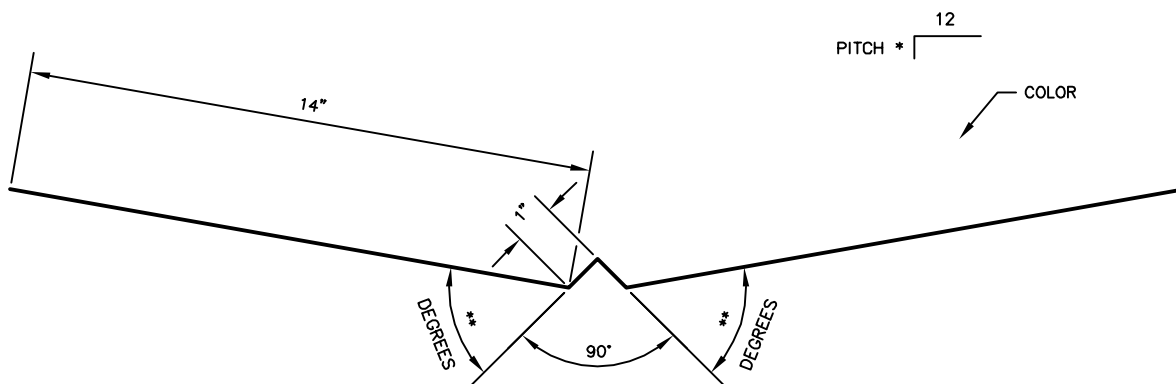

PITCH	**DEGREES
1:12	48.5°
2:12	52°
3:12	55°
4:12	58.5°

## VALLEY TRIM

PANEL PROFILES	GAUGE
MAXIMA 1.5"	24
MAXIMA 2"	24
MAXIMA 3"	24
MAXIMA ADV	24

1-15-15 rev.  
 7-01-13 rev.  
 7-19-11 rev.  
 9-18-97

GIRTH: 30"  
 BENDS: AS SPECIFIED

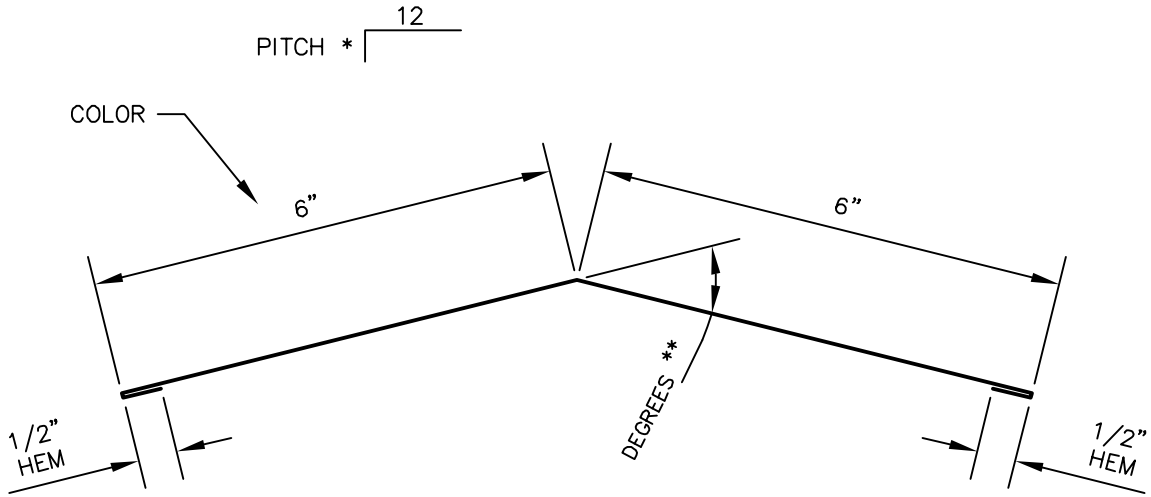

*PITCH	**DEGREES
1:12	7°
2:12	14°
3:12	21°
4:12	27°

### HIP TRIM

PANEL PROFILES	GAUGE
MAXIMA 1.5"	24
MAXIMA 2"	24
MAXIMA 3"	24
MAXIMA ADV	24
MASTERLOK-90	24
MASTERLOK-FS	24

7-01-13 rev.  
 7-20-11  
 5-19-04

GIRTH: 13"  
 BENDS: 90° UNLESS SPECIFIED

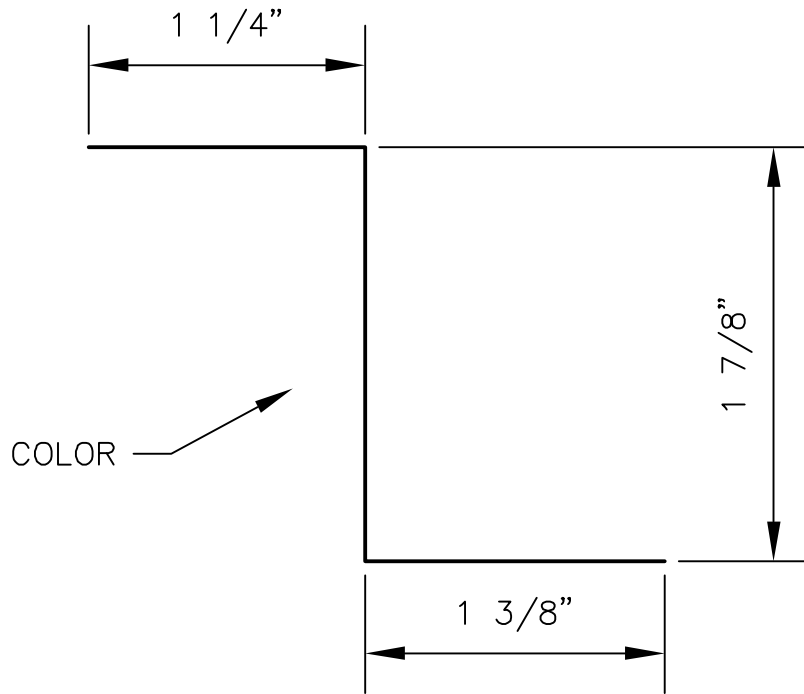

ZEE CLOSURE

PANEL PROFILES	GAUGE
MAXIMA 2"	24
MAXIMA ADV	24

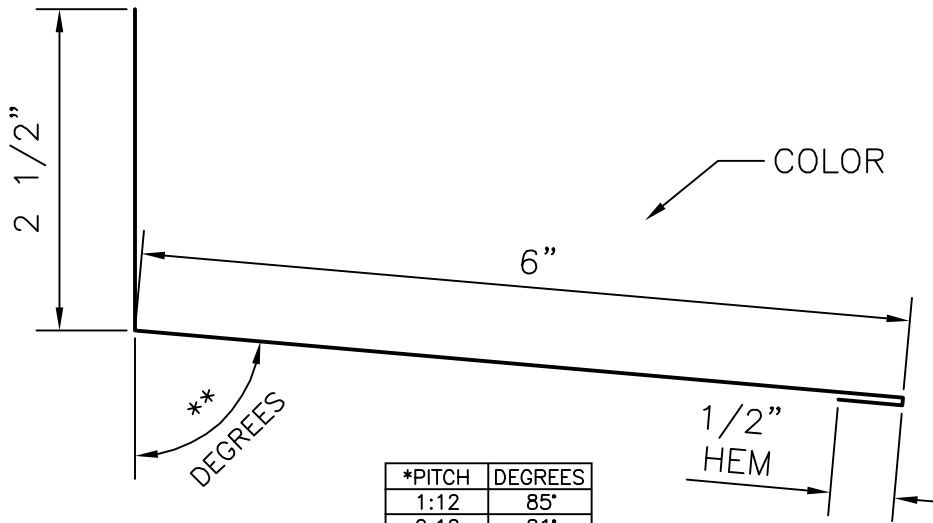
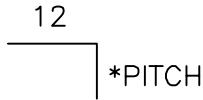

*PITCH	DEGREES
1:12	85°
2:12	81°
3:12	76°
4:12	72°
5:12	67°
6:12	63°
7:12	60°
8:12	56°
9:12	53°
10:12	50°
11:12	47°
12:12	45°

## FIXED HIGH-SIDE TIE-IN FLASHING

PANEL PROFILES	GAUGE
MAXIMA 1.5"	24
MAXIMA 2"	24
MAXIMA 3"	24
MAXIMA ADV	24

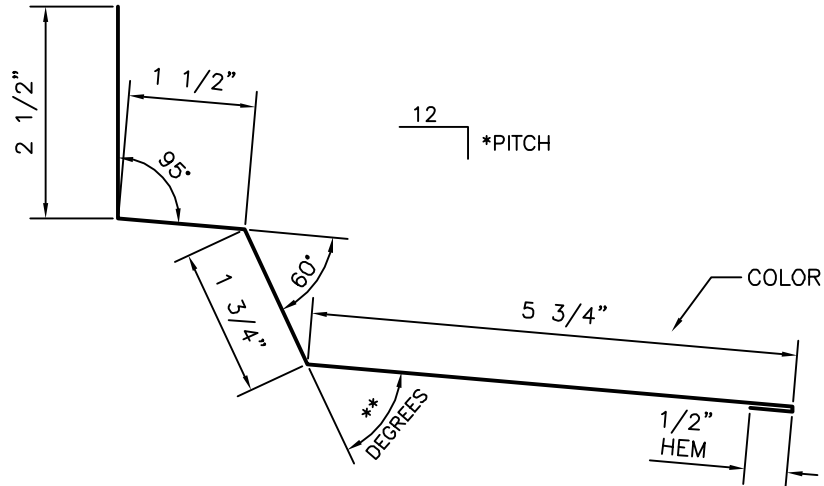

*PITCH	IN DEGREES
1:12	60°
2:12	56°
3:12	52°
4:12	47°
5:12	42°
6:12	38°
7:12	35°
8:12	31°
9:12	28°
10:12	25°
11:12	22°
12:12	20°

## FLOATING HIGH-SIDE TIE-IN TRIM

PANEL PROFILES	GAUGE
MAXIMA 1.5"	24
MAXIMA 2"	24
MAXIMA 3"	24
MAXIMA ADV	24
MASTERLOK-90	24
MASTERLOK-FS	24
MIRAGE I	24
MIRAGE II	24

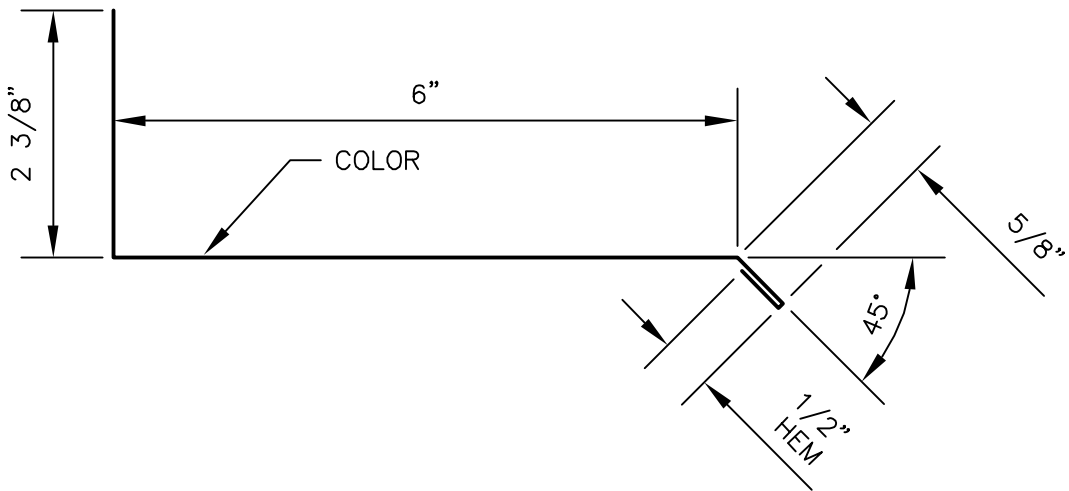

RAKE TIE-IN TRIM

PANEL PROFILES	GAUGE
MAXIMA 1.5"	24
MAXIMA 2"	24
MAXIMA 3"	24
MAXIMA ADV	24

2-04-14 rev.  
6-20-11

GIRTH: 9 1/2"  
BENDS: 90° UNLESS SPECIFIED



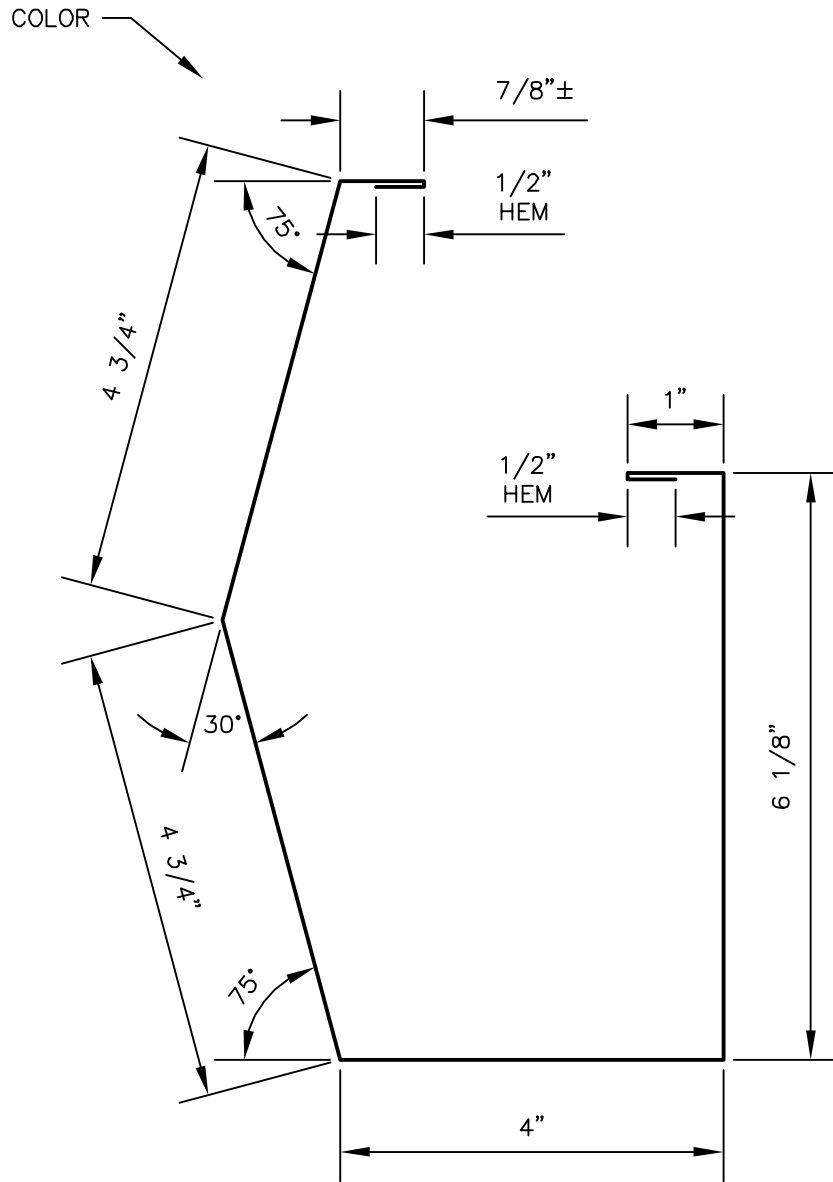

### GUTTER (UP TO 2:12)

(RIGHT HAND SHOWN – LEFT HAND OPPOSITE)  
 (FOR MAXIMA 3" PANEL ONLY)

PANEL PROFILES	GAUGE
MAXIMA 3"	24
MASTERLOK-90	24
MASTERLOK-FS	24

7-01-13 rev.  
 9-27-11 rev.  
 4-16-02

GIRTH: 22 1/2"  
 BENDS: 90° UNLESS NOTED

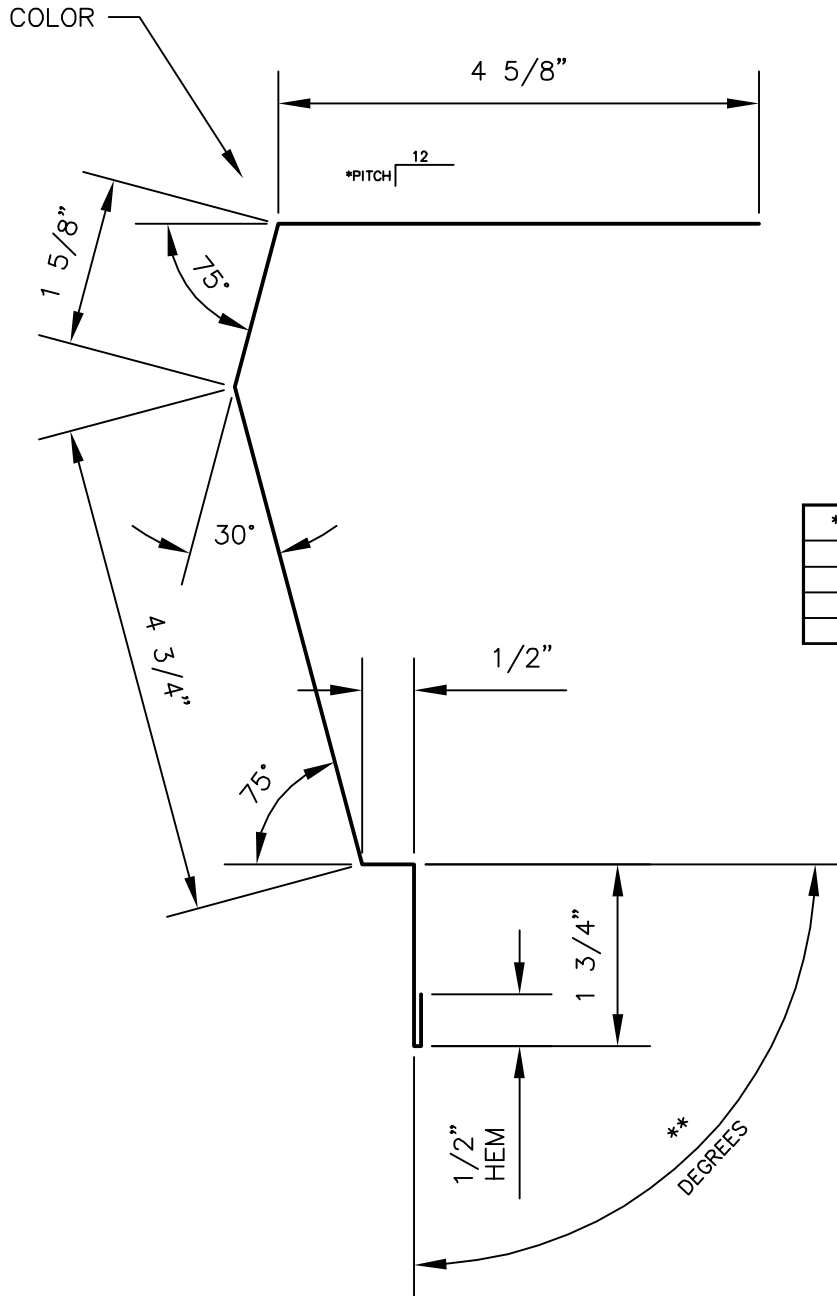

*PITCH	**DEGREES
1:12	95°
2:12	99°
3:12	103°
4:12	108°

### SCULPTURED EAVE TRIM

(MAXIMA 3" ONLY)

PANEL PROFILES	GAUGE
MAXIMA 3"	24
MASTERLOK-90	24
MASTERLOK-FS	24

7-01-13 rev.  
6-20-11

GIRTH: 13 3/4"  
BENDS: 90° UNLESS SPECIFIED

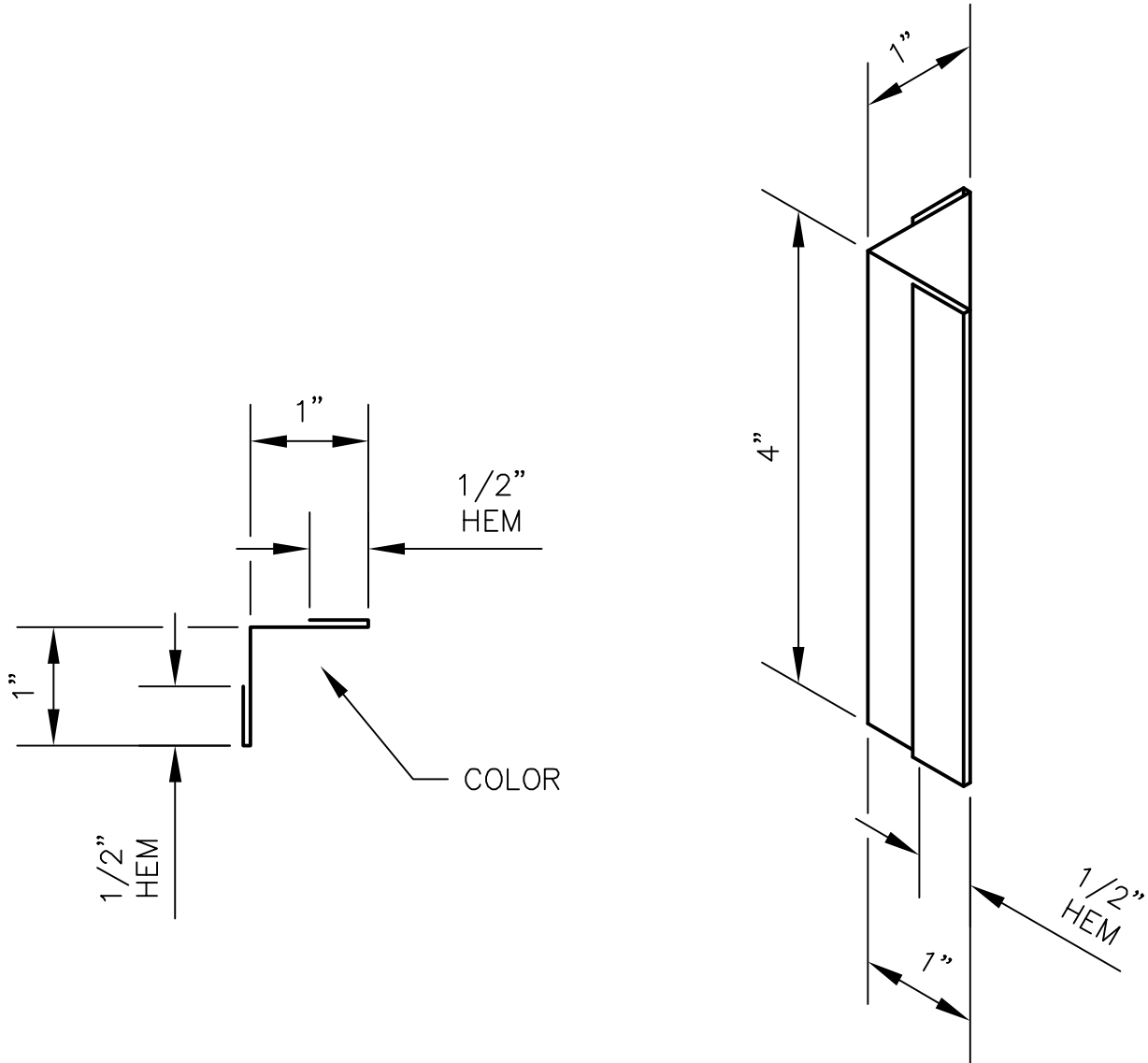

## CINCH ANGLE

PANEL PROFILES	GAUGE
MAXIMA 1.5"	24
MAXIMA 2"	24
MAXIMA 3"	24
MAXIMA ADV	24
MASTERLOK-90	24
MASTERLOK-FS	24
MIRAGE	24
MIRAGE II	24

8-26-13 rev.  
 8-09-11 rev.  
 4-17-02

GIRTH: 3" X 4" LONG  
 BENDS: 90°

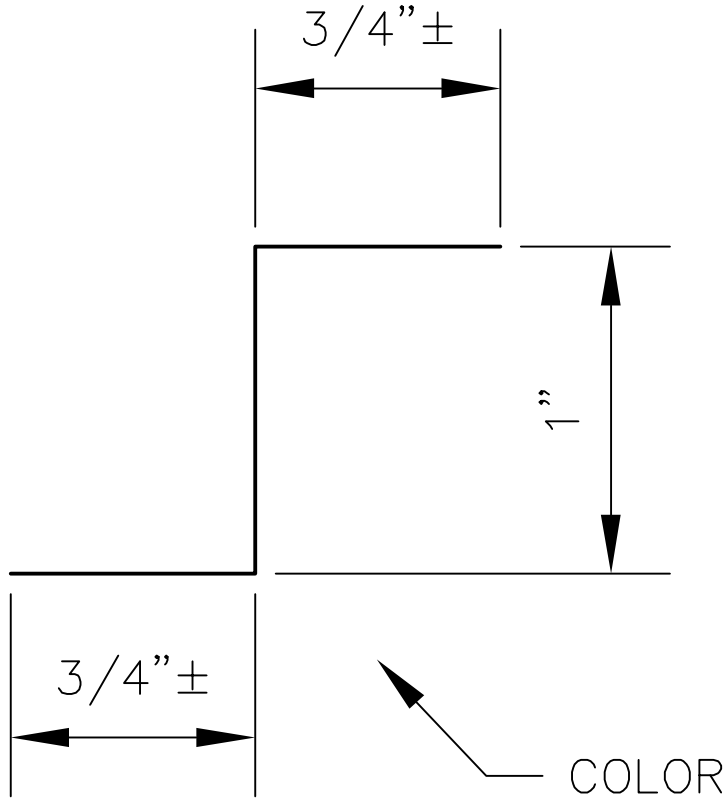

GUTTER STRAP

PANEL PROFILES	GAUGE
MAXIMA 1.5"	24
MAXIMA 2"	24
MAXIMA 3"	24
MASTERLOK-90	24
MASTERLOK-FS	24

7-01-13 rev.  
 9-27-11 rev.  
 4-16-02

GIRTH: 2 1/2"  
 BENDS: 90° UNLESS NOTED

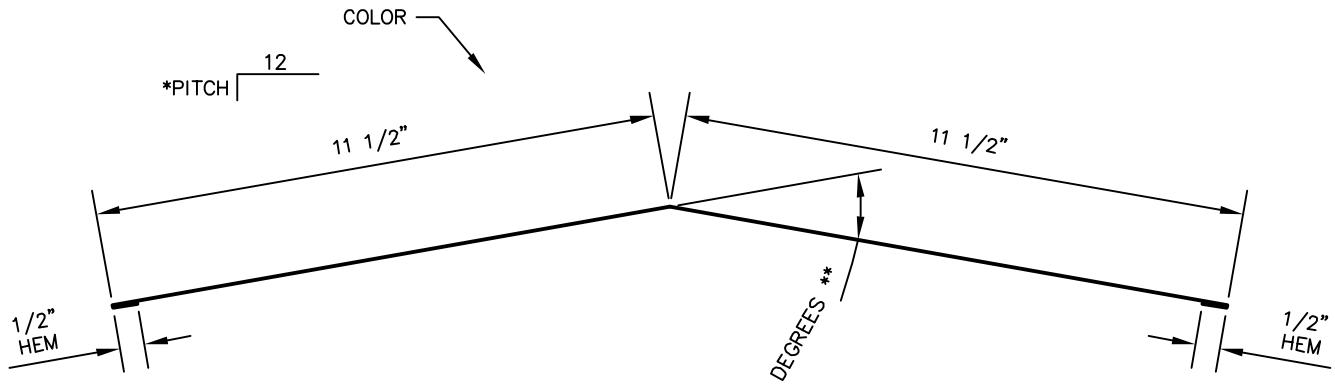

*PITCH	**DEGREES
1:12	10°
2:12	19°
3:12	28°
4:12	37°

## FIXED RIDGE TRIM

(UP TO 4:12 PITCH)

PANEL PROFILES	GAUGE
MAXIMA 1.5"	24
MAXIMA 2"	24
MAXIMA 3"	24
MAXIMA ADV	24
MASTERLOK-90	24
MASTERLOK-FS	24
U-PANEL	26
R-PANEL	26
MULTI-RIB	26
MEGA-RIB	26
M-COR	26
MULTI-COR	26
MIRAGE	26
MIRAGE II	26

7-01-13 rev.  
 7-19-11 rev.  
 4-16-02

GIRTH: 24"  
 BENDS: 90° UNLESS SPECIFIED

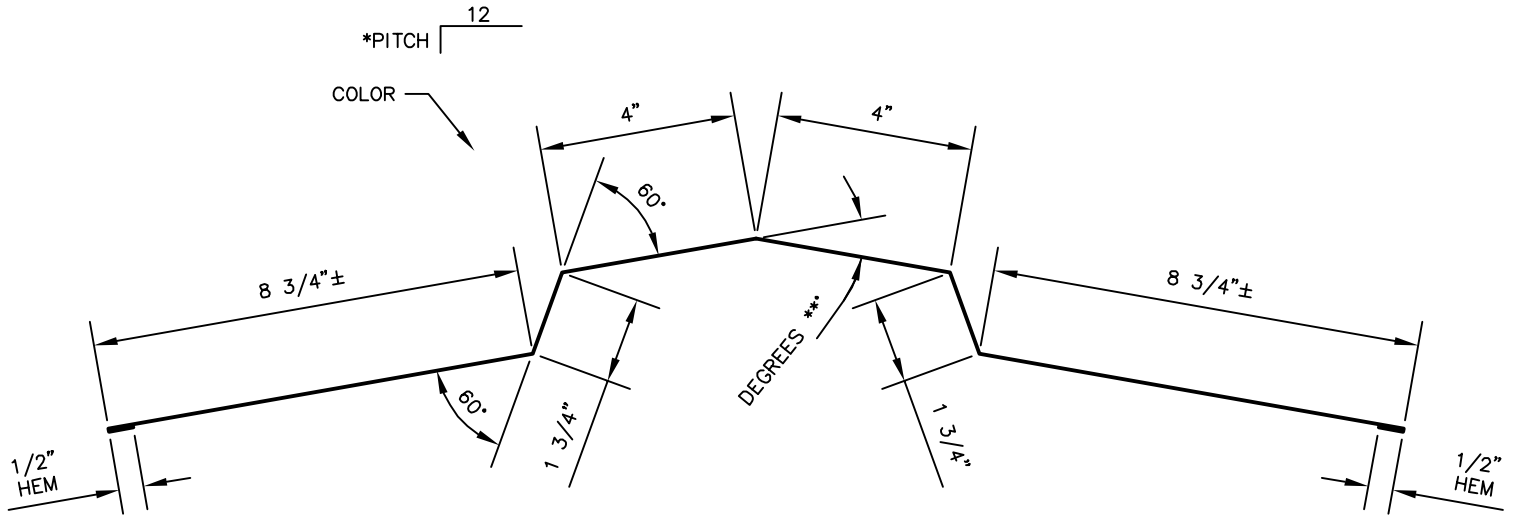

*PITCH	**DEGREES
1:12	10°
2:12	19°
3:12	28°
4:12	37°

## FLOATING RIDGE TRIM

(UP TO 4:12 PITCH)

PANEL PROFILES	GAUGE
MAXIMA 1.5"	24
MAXIMA 2"	24
MAXIMA 3"	24
MAXIMA ADV	24
MASTERLOK-90	24
MASTERLOK-FS	24

7-01-13 rev.  
 7-20-11 rev.  
 4-16-02

GIRTH: 30"  
 BENDS: 90° UNLESS SPECIFIED

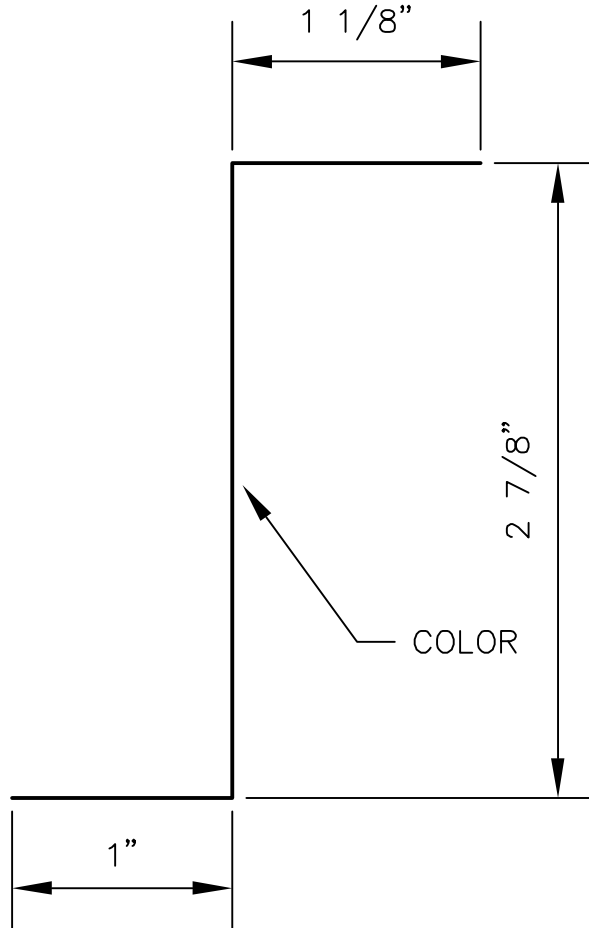

**ZEE CLOSURE**  
 (MAXIMA 3" PANEL ONLY)  
 (MASTERLOK-90 & MASTERLOK-FS)

PANEL PROFILES	GAUGE
MAXIMA 3"	24
MASTERLOK-90	24
MASTERLOK-FS	24

7-01-13 rev.  
 10-12-11 rev.  
 4-17-03 rev.  
 1-03-94

GIRTH: 5"  
 BENDS: 90°

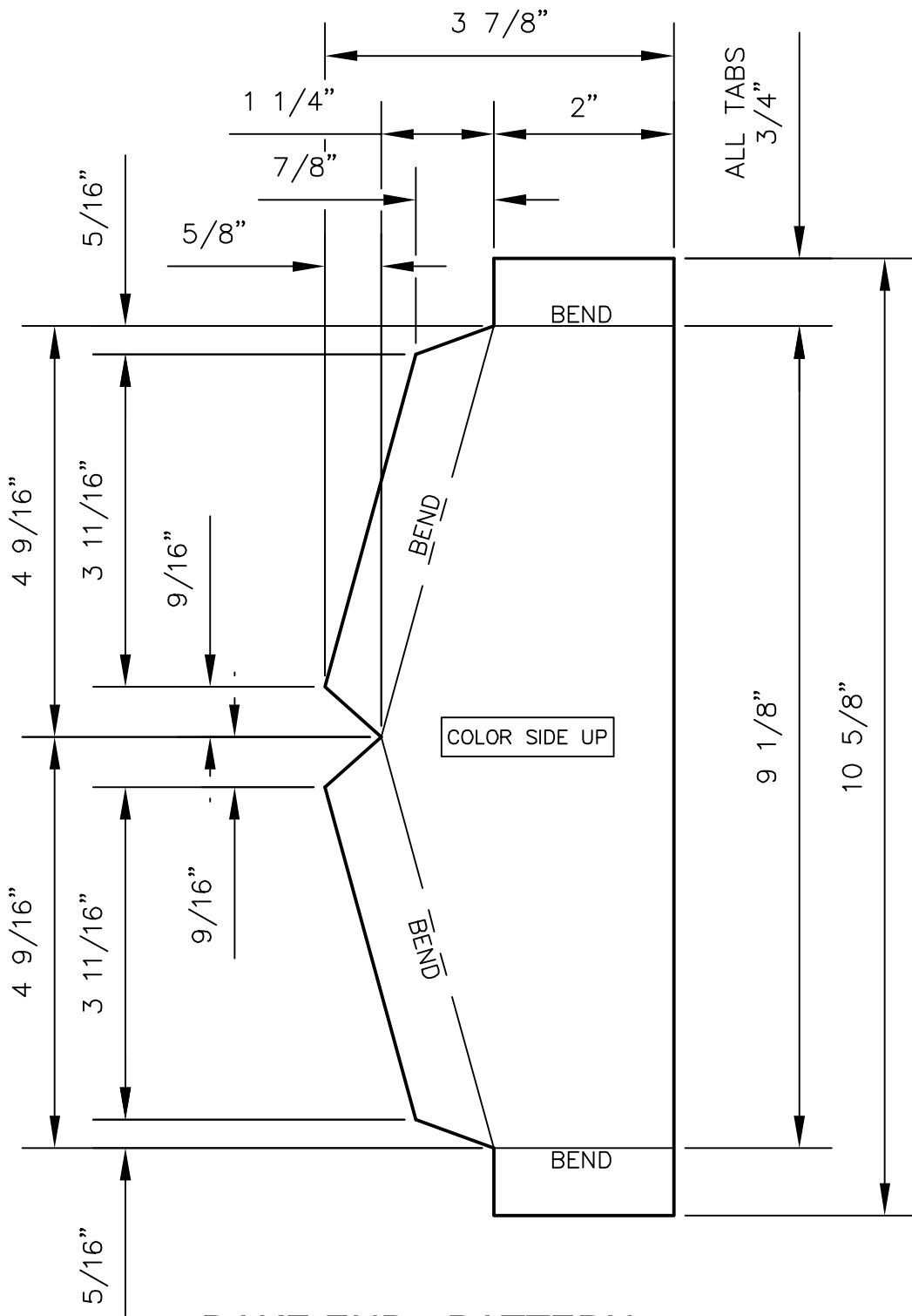

PANEL PROFILES	GAUGE
MAXIMA 1.5"	24 or 26
MAXIMA 2"	24 or 26
MAXIMA 3"	24 or 26
MAXIMA ADV	24 or 26
MASTERLOK-90	24 or 26
MASTERLOK-FS	24 or 26

**RAKE END - PATTERN**

8-26-13 rev.  
 8-09-11 rev.  
 4-16-02

GIRTH: 3 7/8" X 10 5/8"  
 BENDS: DOWN 90°  
 FINISHED DETAIL: MXTW-0130



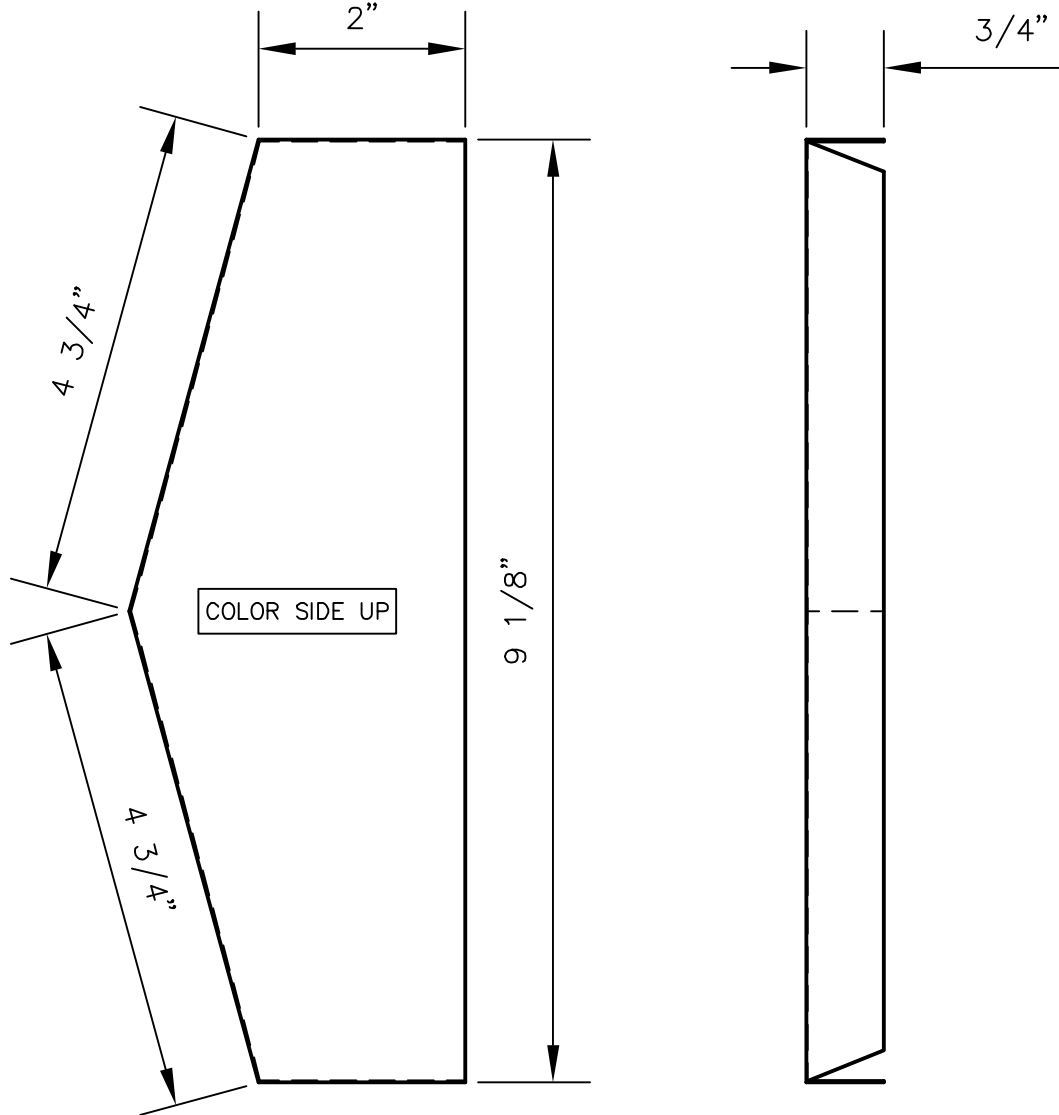

RAKE END - FINISHED

PANEL PROFILES	GAUGE
MAXIMA 1.5"	24 or 26
MAXIMA 2"	24 or 26
MAXIMA 3"	24 or 26
MAXIMA ADV	24 or 26
MASTERLOK-90	24 or 26
MASTERLOK-FS	24 or 26

8-26-13 rev.  
 8-09-11 rev.  
 4-16-02

GIRTH: SEE PATTERN MXTW-0129  
 BENDS: DOWN 90°  
 SEE PATTERN: MXTW-0129

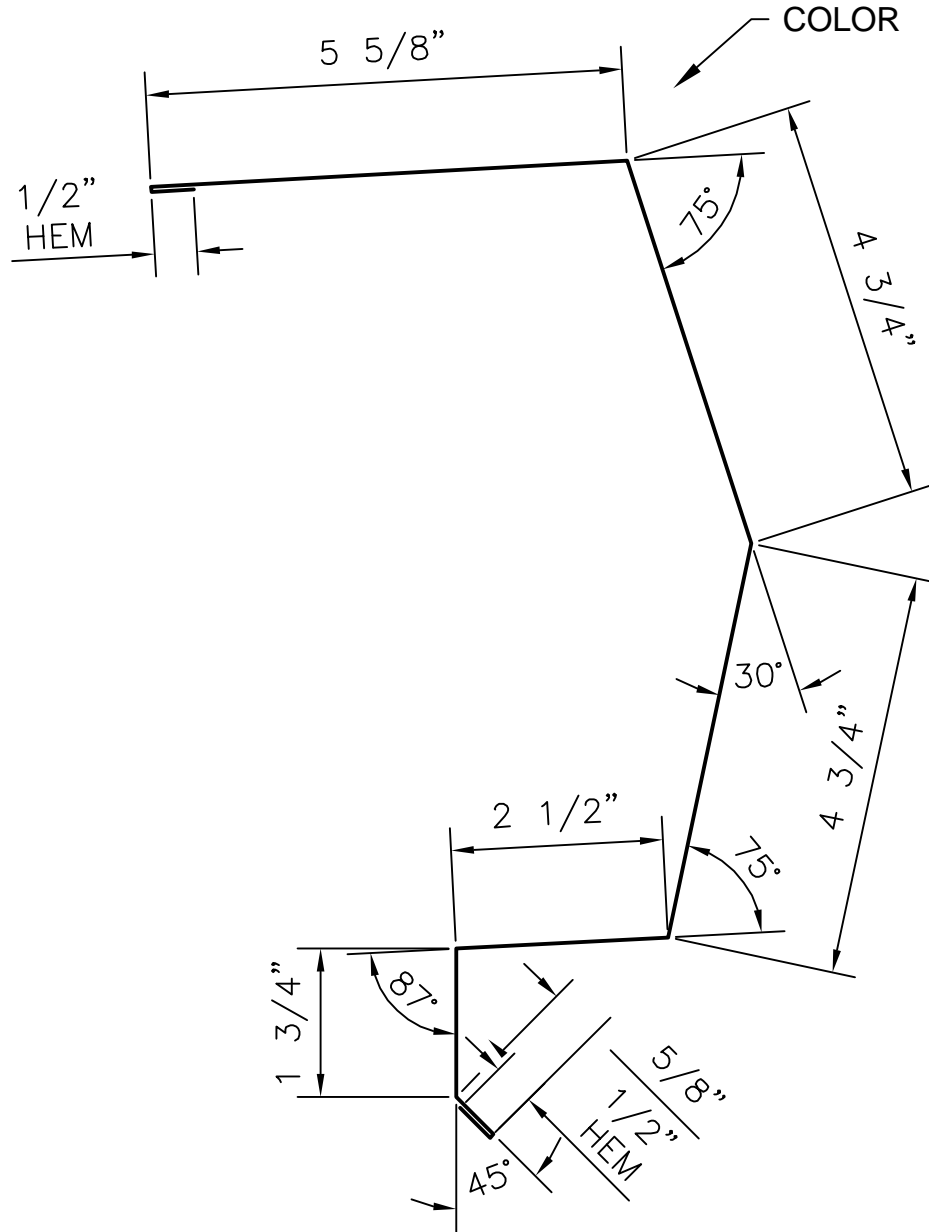

## HIGH SIDE EAVE TRIM

(FOR UP TO 2:12 PITCH)

PANEL PROFILES	GAUGE
MAXIMA 1.5"	24
MAXIMA 2"	24
MAXIMA 3"	24
MAXIMA ADV	24
MASTERLOK-90	24
MASTERLOK-FS	24

6-25-13 rev.  
 4-09-13 rev.  
 4-29-11

GIRTH: 21"  
 BENDS: AS SPECIFIED

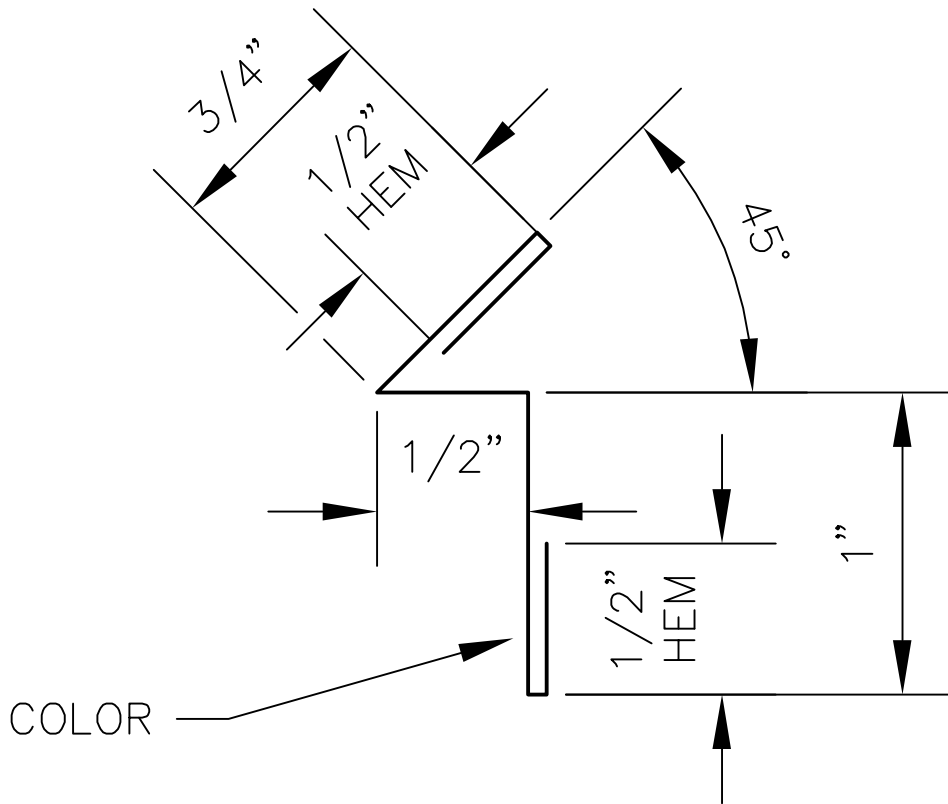

## RAKE SLIDE

PANEL PROFILES	GAUGE
MAXIMA 1.5"	24
MAXIMA 2"	24
MAXIMA 3"	24
MAXIMA ADV	24
MASTERLOK-90	24
MASTERLOK-FS	24
MIRAGE	24
MIRAGE II	24

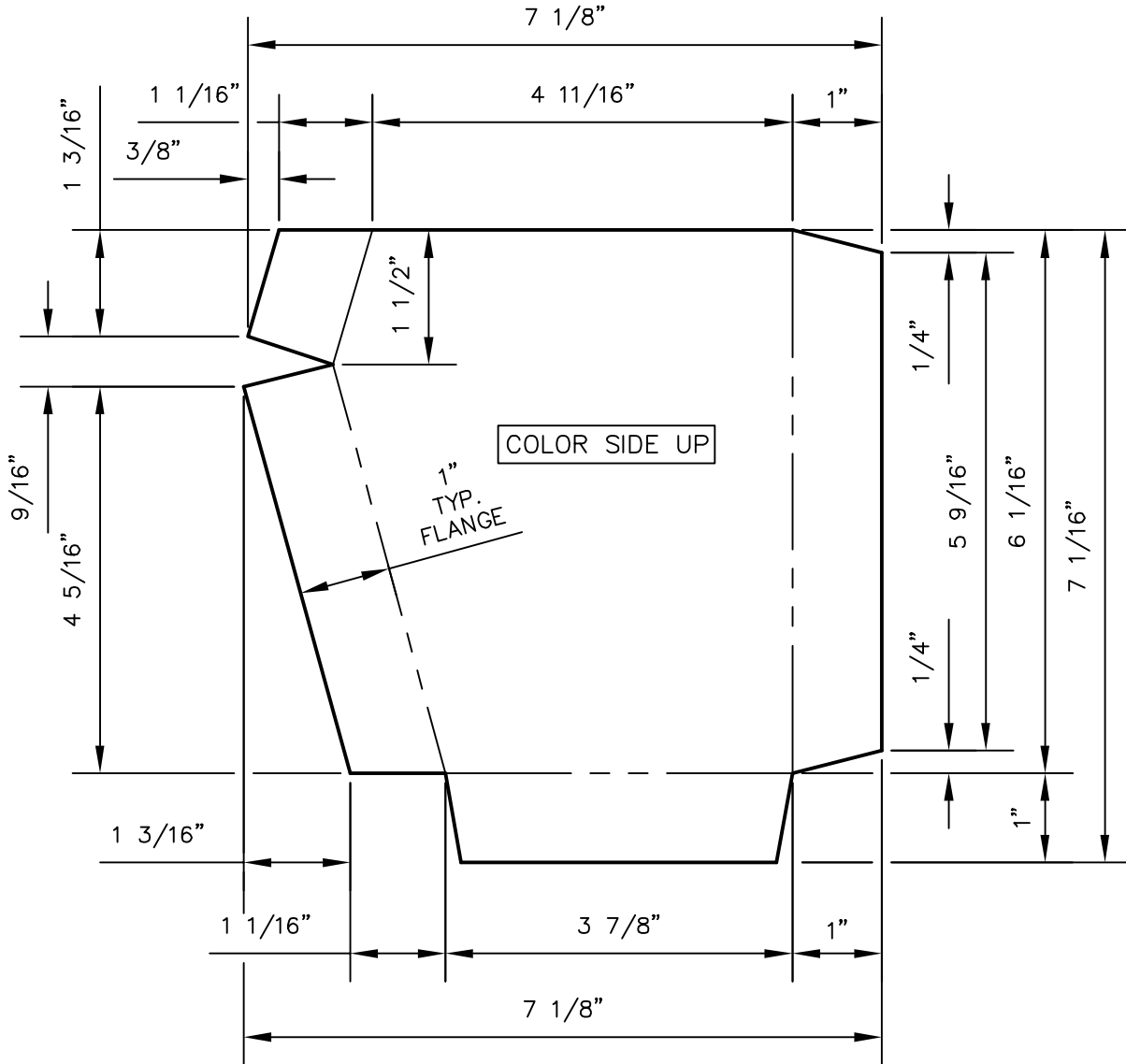

**GUTTER END CAP (UP TO 2:12) - PATTERN**

(RIGHT HAND SHOWN – LEFT HAND OPPOSITE)

PANEL PROFILES	GAUGE
MAXIMA 3"	24 or 26
MASTERLOK-90	24 or 26
MASTERLOK-FS	24 or 26

8-22-13 rev.  
 9-27-11 rev.  
 4-17-02

GIRTH: 7 1/16" X 7 1/8"  
 BENDS: DOWN 90°  
 FINISHED DETAIL: MXTW-0134

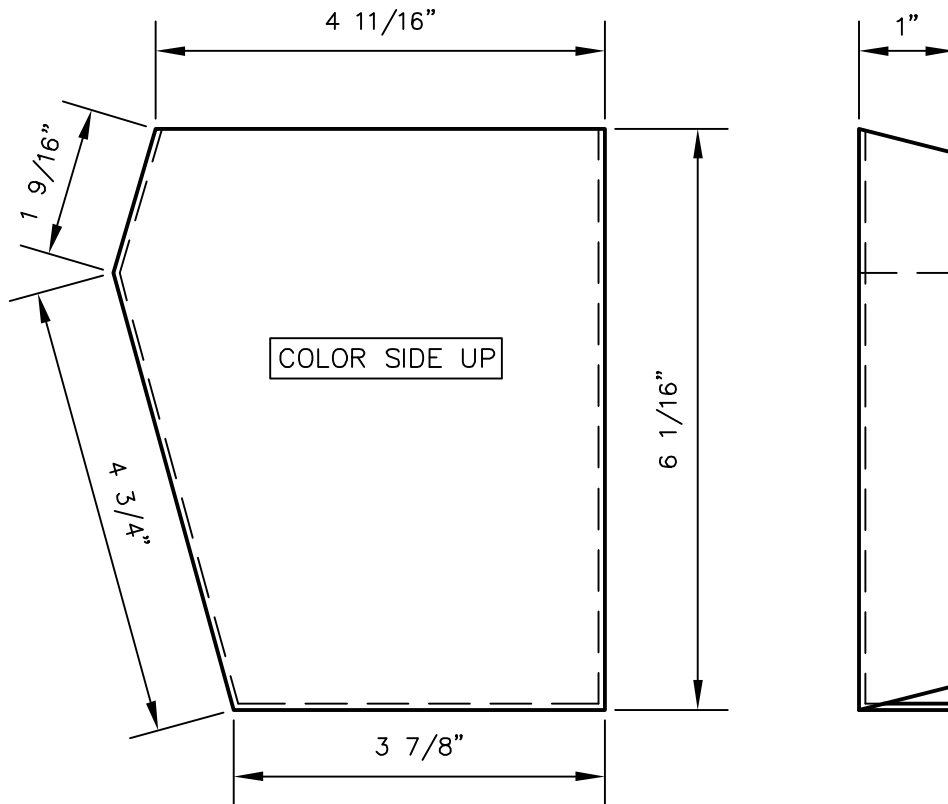

## GUTTER END CAP (UP TO 2:12) - FINISHED

(RIGHT HAND SHOWN – LEFT HAND OPPOSITE)

(FOR MAXIMA 3" PANEL ONLY)

PANEL PROFILES	GAUGE
MAXIMA 3"	24 or 26
MASTERLOK-90	24 or 26
MASTERLOK-FS	24 or 26

8-22-13 rev.  
9-27-11 rev.  
4-17-02

GIRTH: SEE PATTERN MXTW-0133  
BENDS: SEE PATTERN MXTW-0133

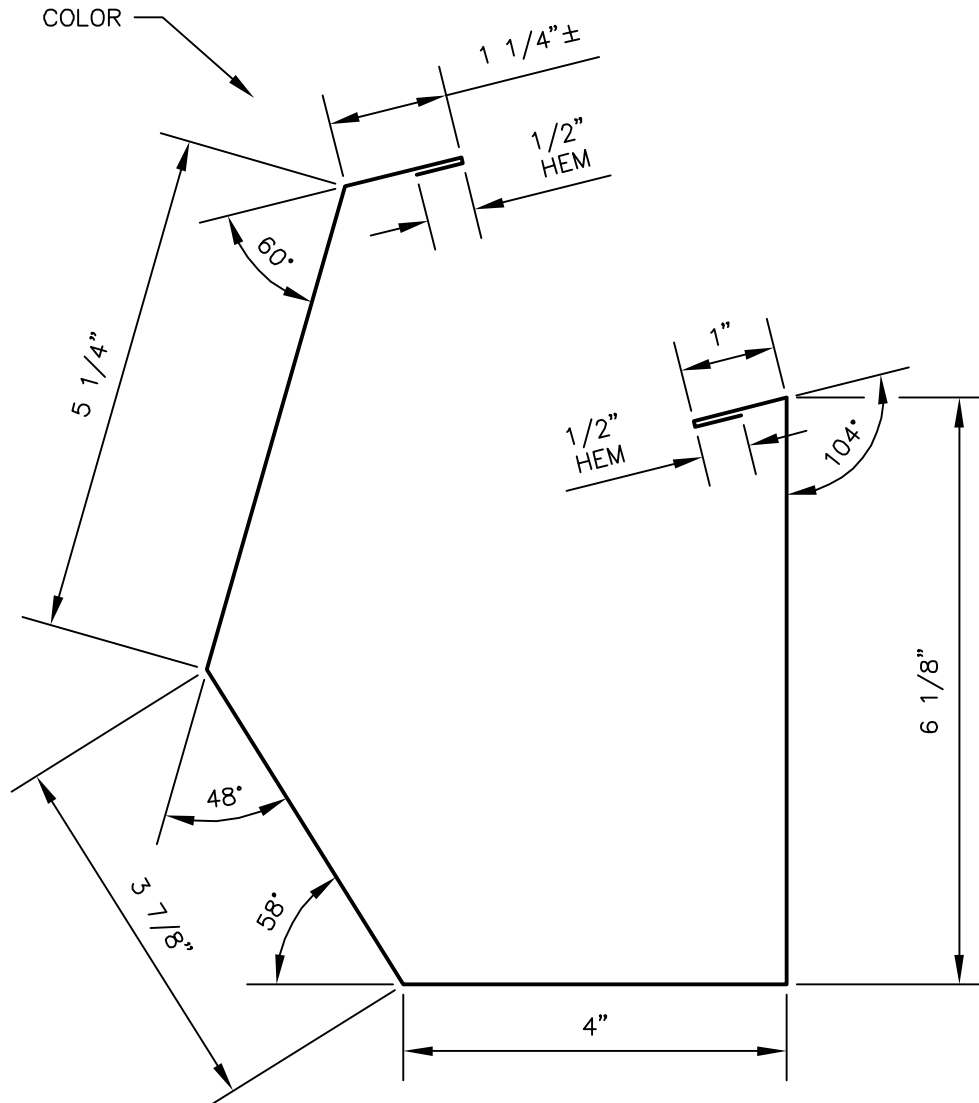

**GUTTER (2:12 TO 4:12)**

(RIGHT HAND SHOWN – LEFT HAND OPPOSITE)

PANEL PROFILES	GAUGE
MAXIMA 3"	24
MASTERLOK-90	24
MASTERLOK-FS	24

7-01-13 rev.  
 9-27-11 rev.  
 1-17-02

GIRTH: 22 1/2"  
 BENDS: 90° AND AS SPECIFIED

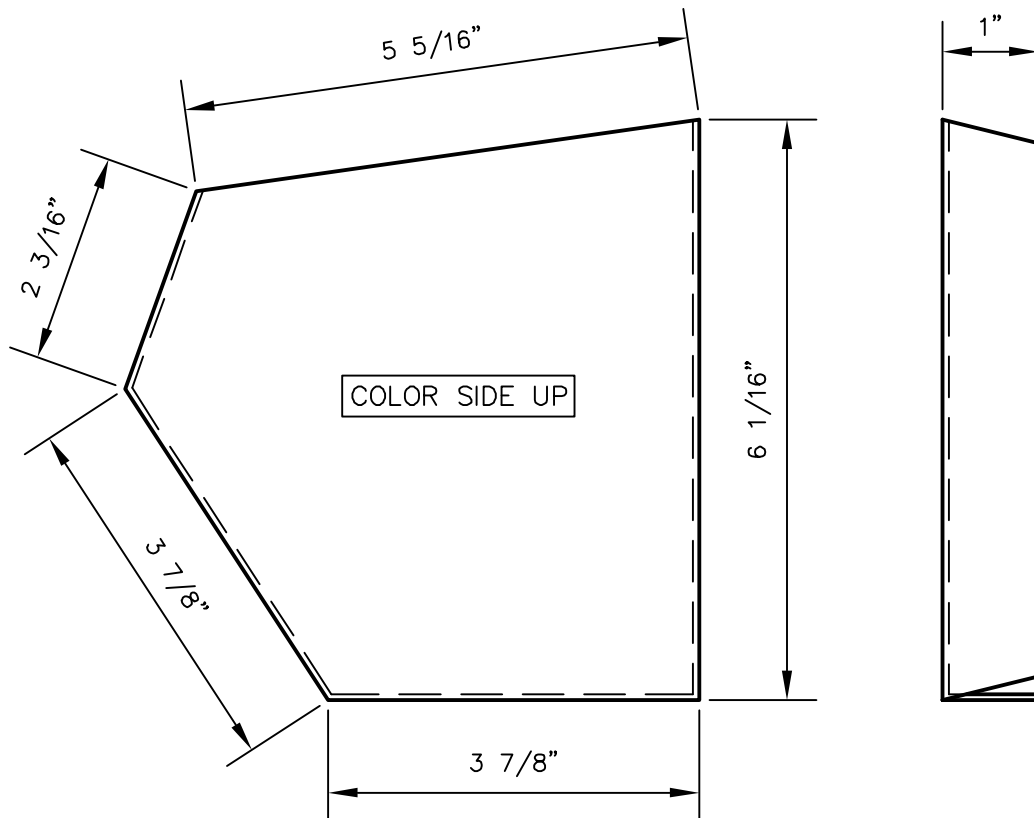

## GUTTER END CAP (2:12 TO 4:12) - FINISHED

(RIGHT HAND SHOWN – LEFT HAND OPPOSITE)

PANEL PROFILES	GAUGE
MAXIMA 3"	24 or 26
MASTERLOK-90	24 or 26
MASTERLOK-FS	24 or 26

8-22-13 rev.  
9-27-11 rev.  
4-17-02

GIRTH: SEE PATTERN MXTW-0137  
BENDS: SEE PATTERN MXTW-0137

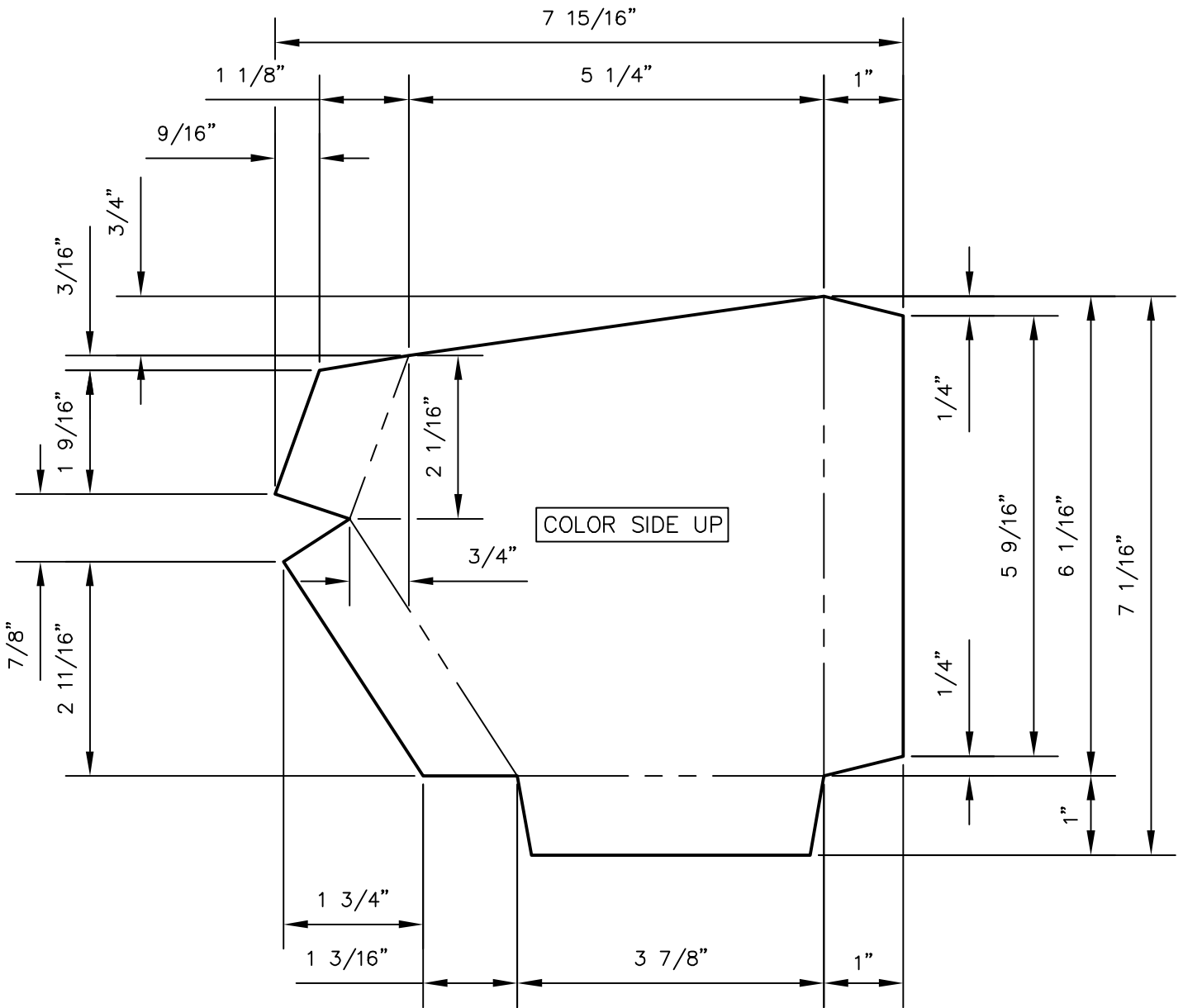

### GUTTER END CAP (2:12 TO 4:12) - PATTERN

(RIGHT HAND SHOWN – LEFT HAND OPPOSITE)

PANEL PROFILES	GAUGE
MAXIMA 3"	24 or 26
MASTERLOK-90	24 or 26
MASTERLOK-FS	24 or 26

8-22-13 rev.  
 9-27-11 rev.  
 4-17-02

GIRTH:  $7 \frac{15}{16}$ " X  $7 \frac{1}{16}$ "  
 BENDS: DOWN 90°  
 FINISHED DETAIL: MXTW-0136



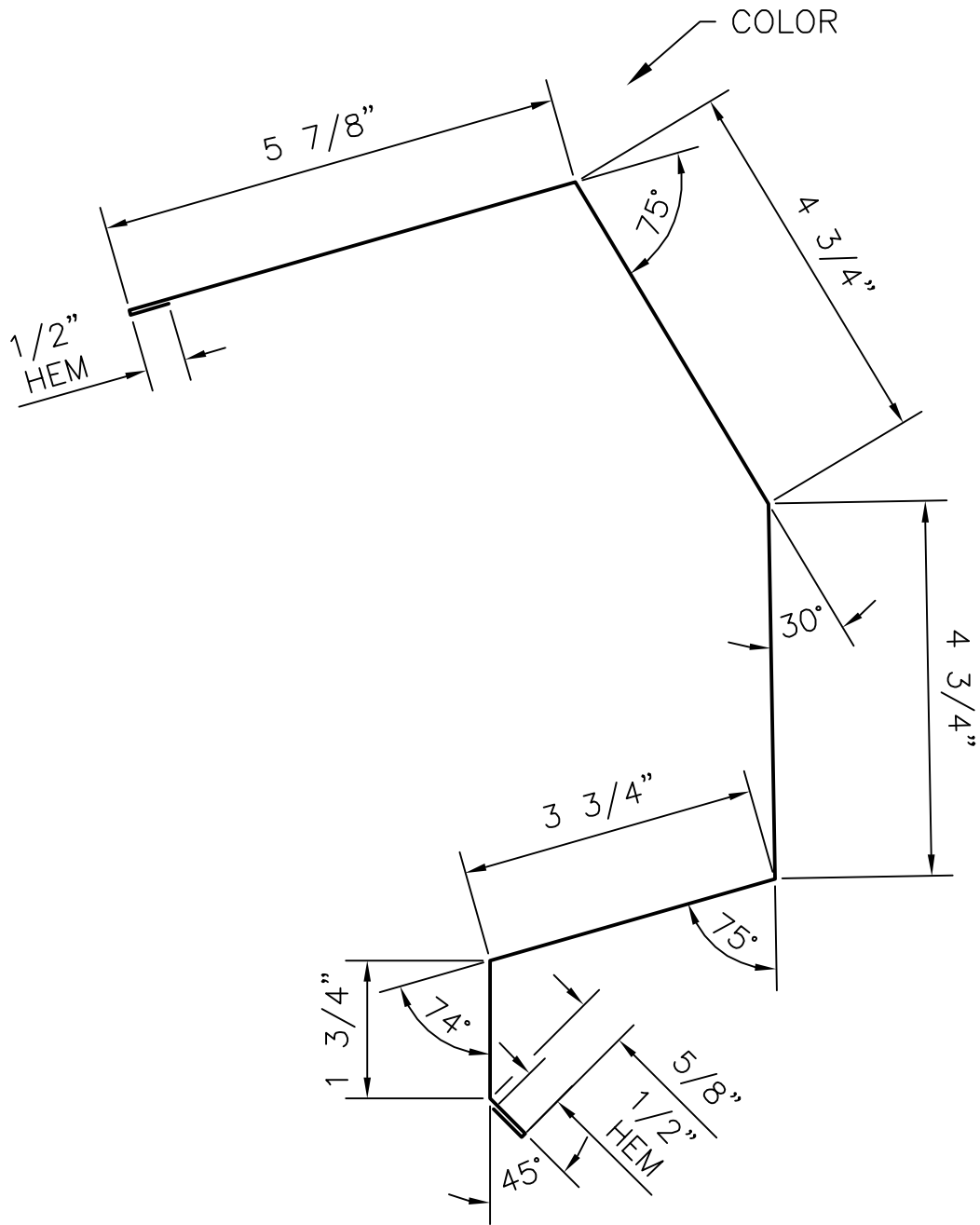

## HIGH SIDE EAVE TRIM

(FOR 2:12 - 4:12 PITCH)

PANEL PROFILES	GAUGE
MAXIMA 1.5"	24
MAXIMA 2"	24
MAXIMA 3"	24
MAXIMA ADV	24
MASTERLOK-90	24
MASTERLOK-FS	24

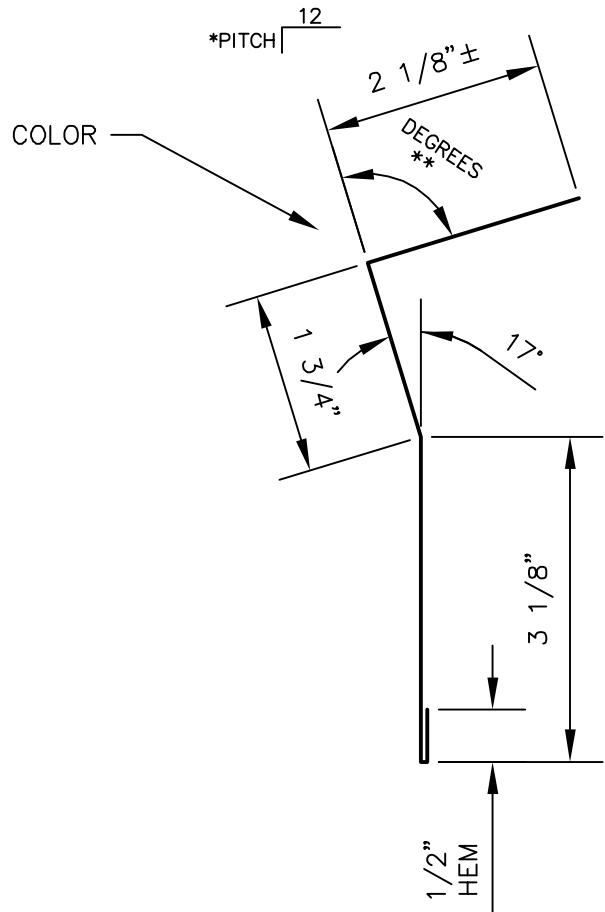

*PITCH	**DEGREES
1:12	104°
2:12	99°
3:12	94°
4:12	90°

### SIMPLE EAVE TRIM

PANEL PROFILES	GAUGE
MAXIMA 1.5"	24
MAXIMA 2"	24
MAXIMA 3"	24
MAXIMA ADV	24
MAXIMA 3"	24
MASTERLOK-90	24
MASTERLOK-FS	24

7-01-13 rev.  
6-20-11

GIRTH: 7 1/2"  
BENDS: 90° UNLESS SPECIFIED

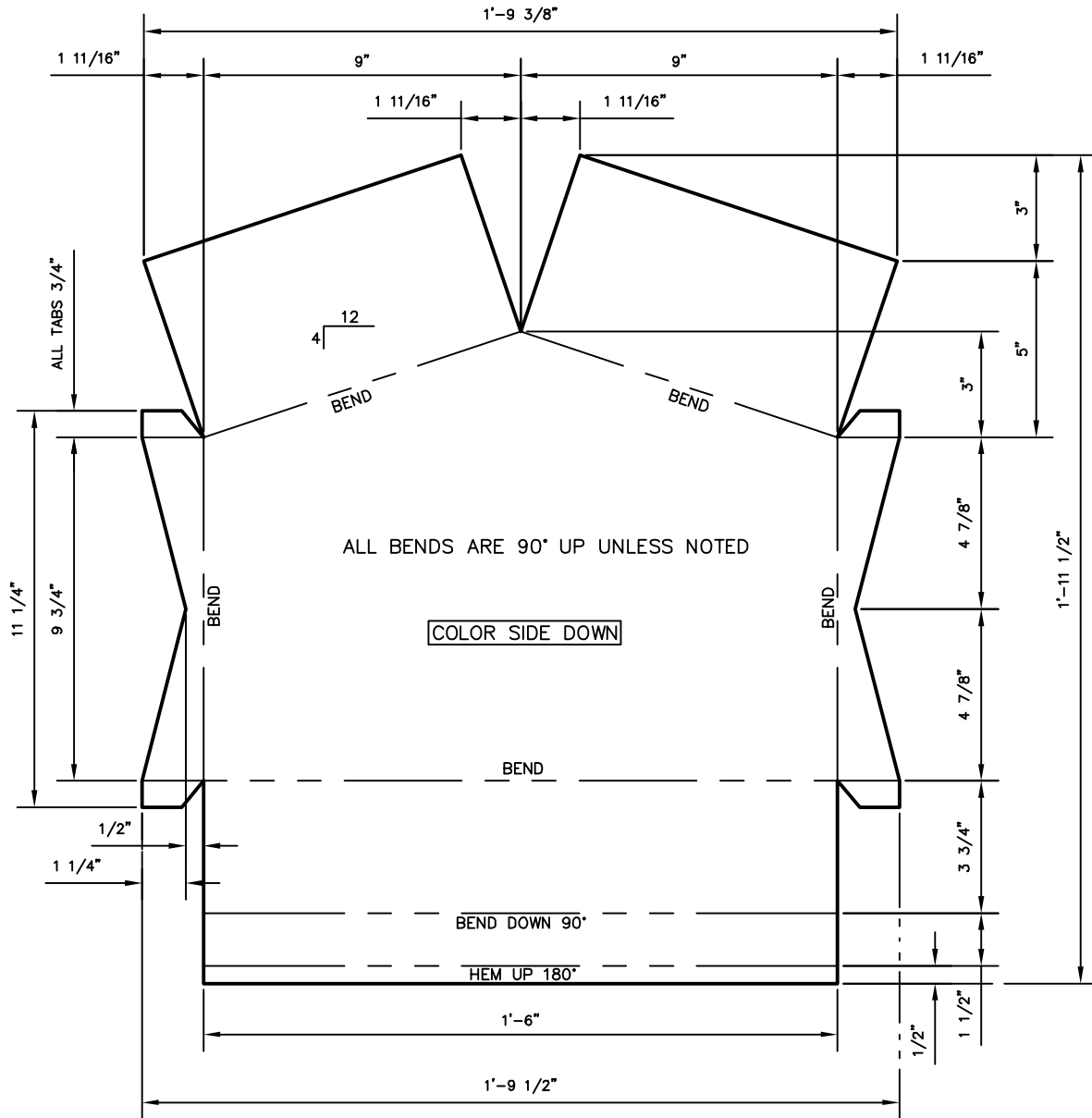

## PEAK BOX (2:12 - 4:12) - PATTERN

PANEL PROFILES	GAUGE
MAXIMA 1.5"	24
MAXIMA 2"	24
MAXIMA 3"	24
MAXIMA ADV	24
MASTERLOK-FS	24
MASTERLOK-90	24

7-01-13 rev.  
 8-09-11 rev.  
 4-17-02

GIRTH: 1'-9 1/2" X 1'-11 1/2"  
 BENDS: 90° AND AS SPECIFIED

241A

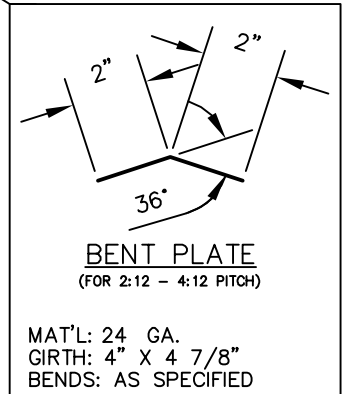
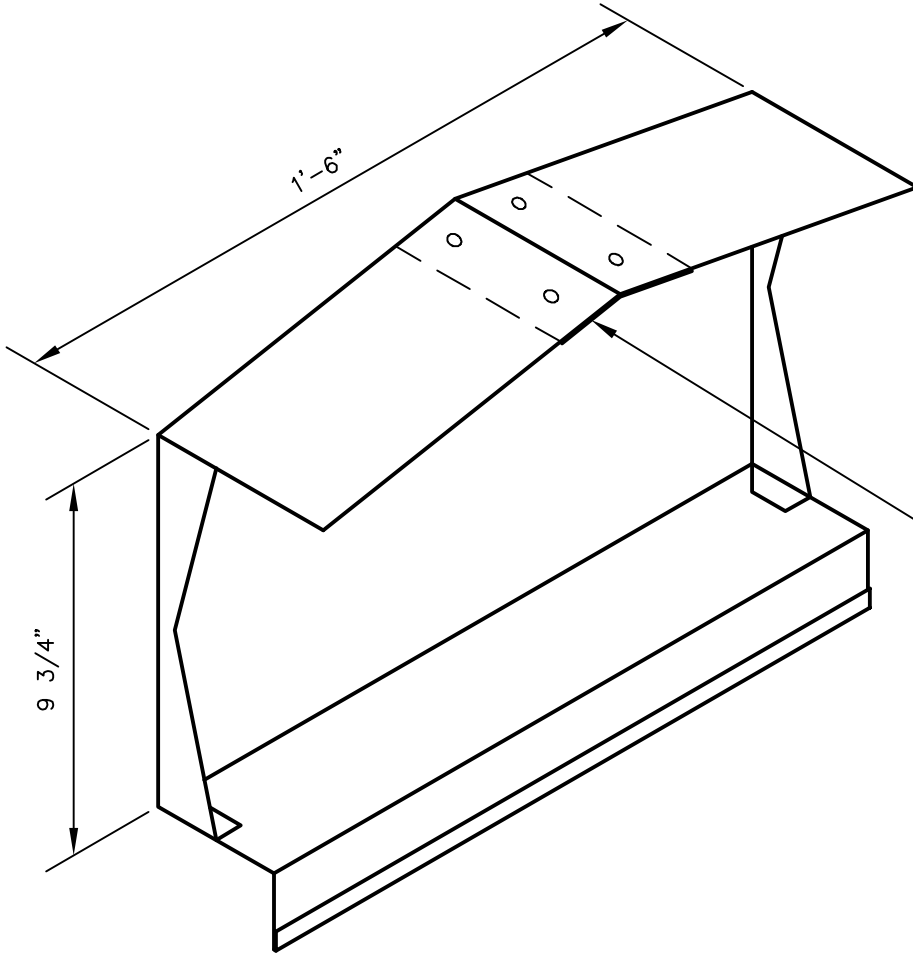

**PEAK BOX - FINISHED**  
(FOR 2:12 TO 4:12)

PANEL PROFILES	GAUGE
MAXIMA 1.5"	24
MAXIMA 2"	24
MAXIMA 3"	24
MAXIMA ADV	24
MASTERLOK-FS	24
MASTERLOK-90	24

7-01-13 rev.  
8-10-11 rev.  
4-17-02

GIRTH: SEE PATTERN: MXTW-0140  
BENDS: SEE PATTERN: MXTW-0140

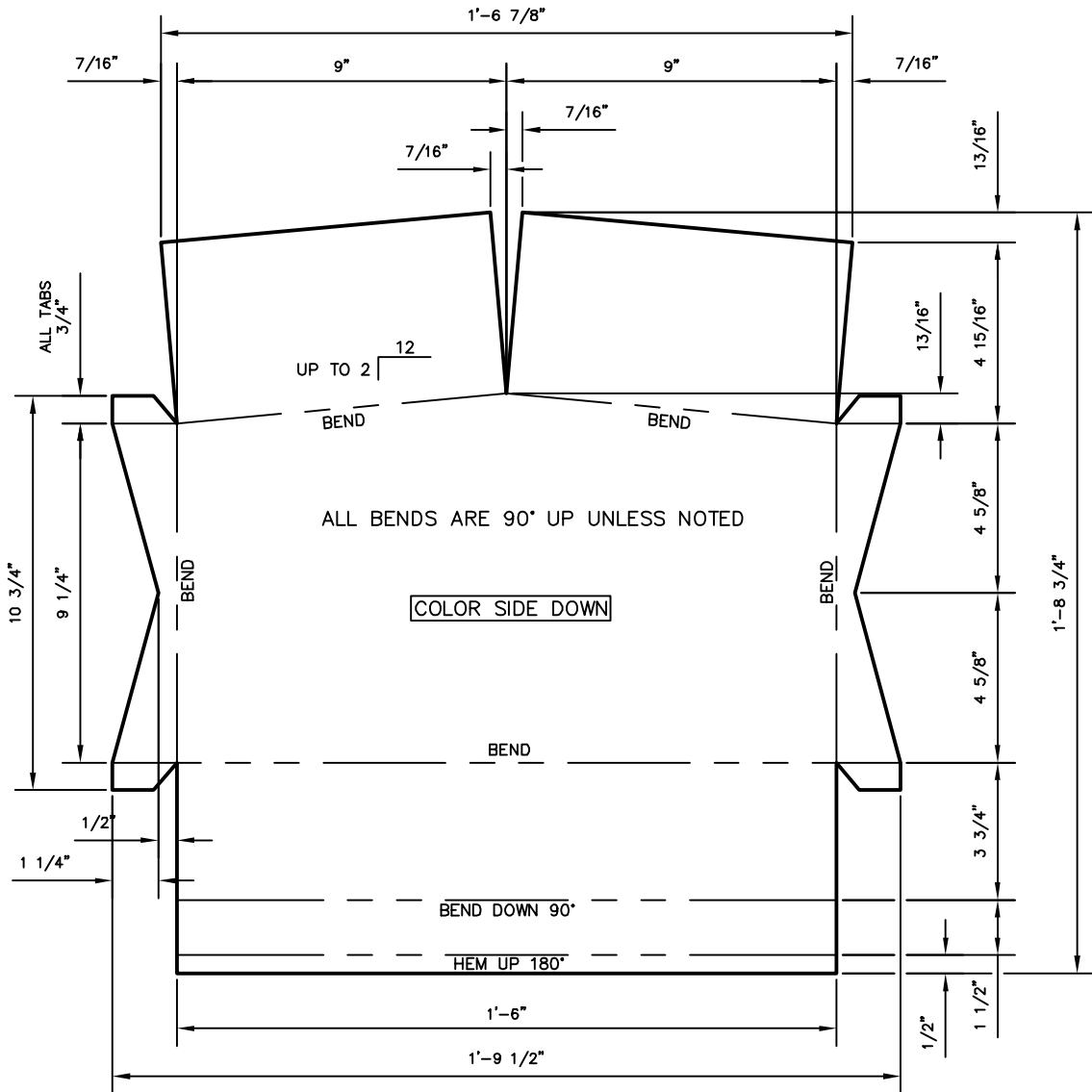

**PEAK BOX (UP TO 2:12) - PATTERN**

PANEL PROFILES	GAUGE
MAXIMA 1.5"	24
MAXIMA 2"	24
MAXIMA 3"	24
MAXIMA ADV	24
MASTERLOK-FS	24
MASTERLOK-90	24

7-01-13 rev.  
 8-09-11 rev.  
 4-17-02

GIRTH: 1'-9 1/2" X 1'-8 3/4"  
 BENDS: 90° AND AS SPECIFIED

239A

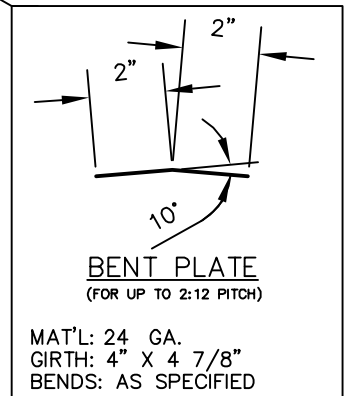
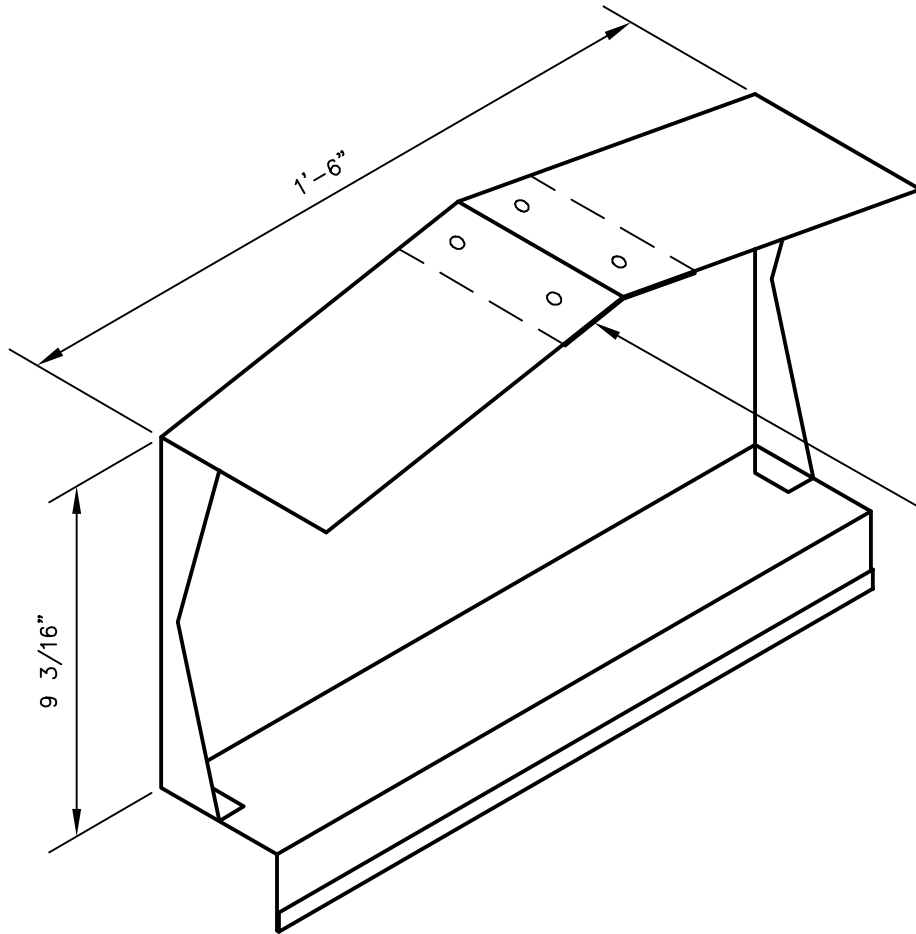

## PEAK BOX - FINISHED

(FOR UP TO 2:12 PITCH)

PANEL PROFILES	GAUGE
MAXIMA 1.5"	24
MAXIMA 2"	24
MAXIMA 3"	24
MAXIMA ADV	24
MASTERLOK-FS	24
MASTERLOK-90	24

7-01-13 rev.  
8-10-11 rev.  
4-17-02

GIRTH: SEE PATTERN: MXTW-0142  
BENDS: SEE PATTERN: MXTW-0142

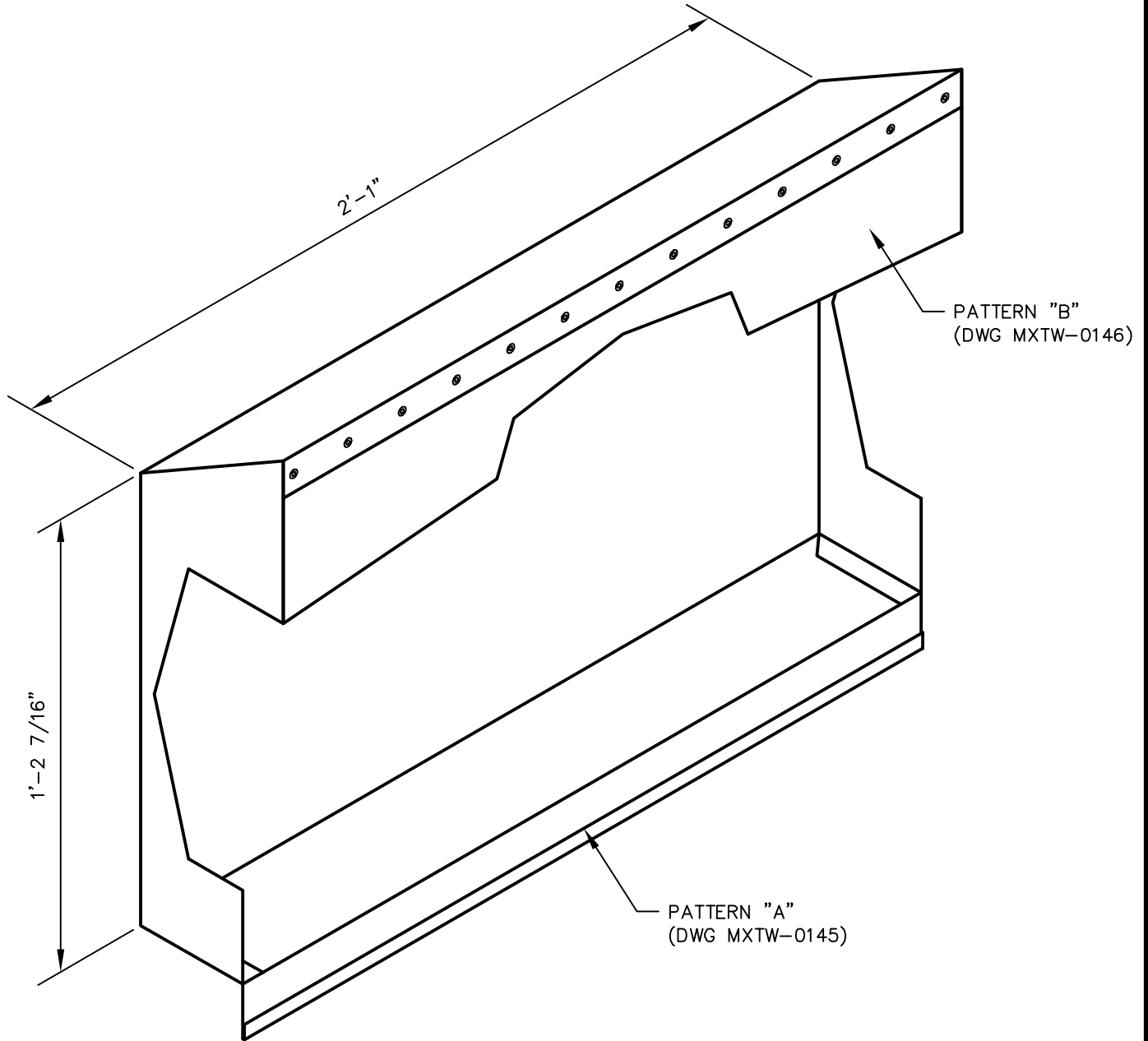

PANEL PROFILES	GAUGE
MAXIMA 1.5"	24
MAXIMA 2"	24
MAXIMA 3"	24
MAXIMA ADV	24
MASTERLOK-FS	24
MASTERLOK-90	24

## FLOATING PEAK BOX - FINISHED

(FOR UP TO 2:12)

7-01-13 rev.  
7-26-11 rev.  
4-17-02

GIRTH: SEE PATTERN: MXTW-0145 & MXTW-0146  
BENDS: SEE PATTERN: MXTW-0145 & MXTW-0146

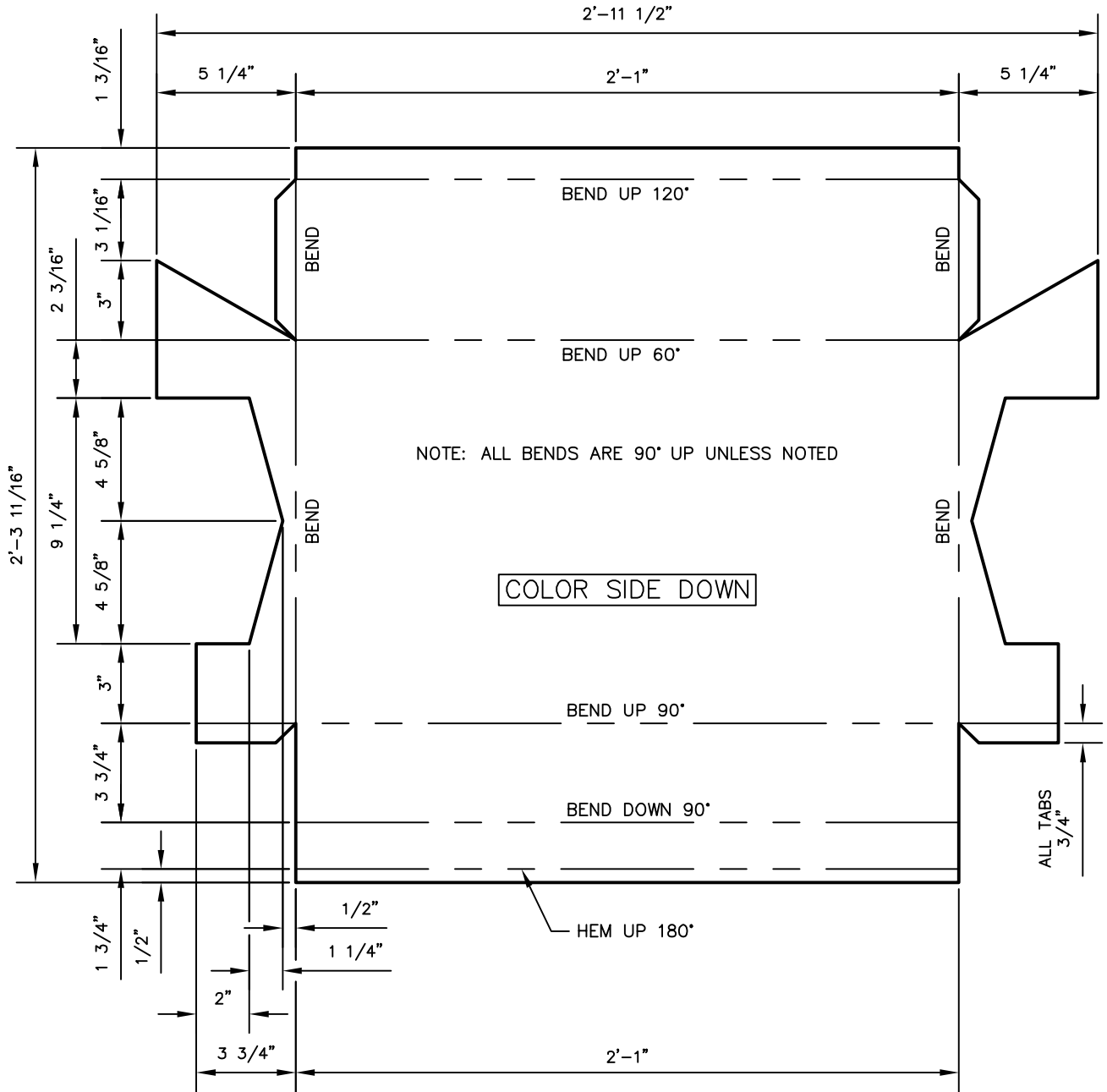

PANEL PROFILES	GAUGE
MAXIMA 1.5"	24
MAXIMA 2"	24
MAXIMA 3"	24
MAXIMA ADV	24
MASTERLOK-FS	24
MASTERLOK-90	24

**FLOATING PEAK BOX - PATTERN "A"**  
 (FOR UP TO 2:12 PITCH)

7-01-13 rev.  
 7-26-11 rev.  
 4-17-02

GIRTH: 2'-3 11/16" X 2'-11 1/2"  
 BENDS: 90° AND AS SPECIFIED



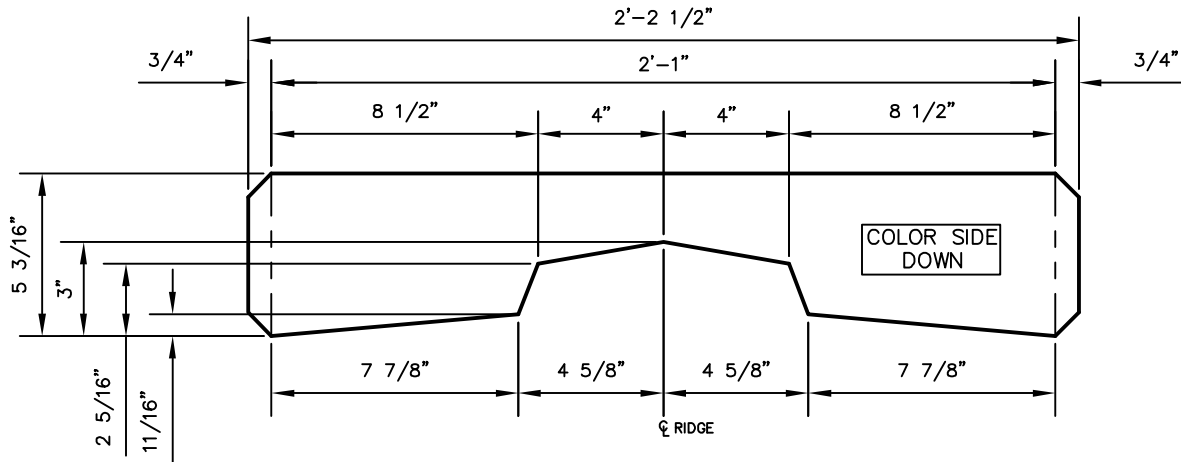

**FLOATING PEAK BOX - PATTERN "B"**  
 (FOR UP TO 2:12 PITCH)

PANEL PROFILES	GAUGE
MAXIMA 1.5"	24
MAXIMA 2"	24
MAXIMA 3"	24
MAXIMA ADV	24
MASTERLOK-FS	24
MASTERLOK-90	24

7-01-13 rev.  
 7-26-11 rev.  
 4-17-02

GIRTH: 5 3/16" X 2'-2 1/2"  
 BENDS: UP 90°

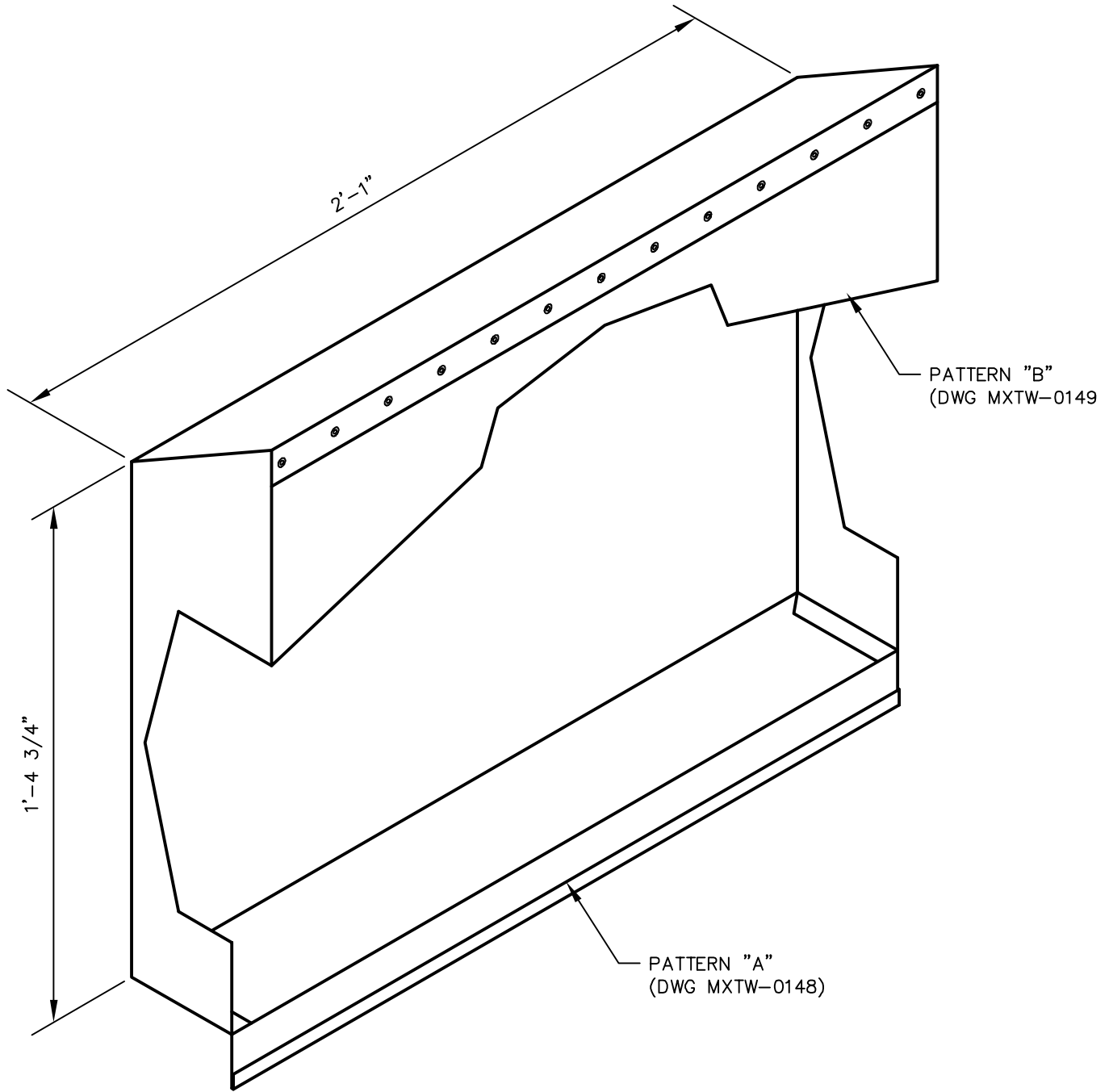

PANEL PROFILES	GAUGE
MAXIMA 1.5"	24
MAXIMA 2"	24
MAXIMA 3"	24
MAXIMA ADV	24
MASTERLOK-FS	24
MASTERLOK-90	24

## FLOATING PEAK BOX - FINISHED

(FOR 2:12 TO 4:12)

7-01-13 rev.  
7-26-11 rev.  
2-20-04

GIRTH: SEE PATTERN: MXTW-0148 & MXTW-0149  
BENDS: SEE PATTERN: MXTW-0148 & MXTW-0149

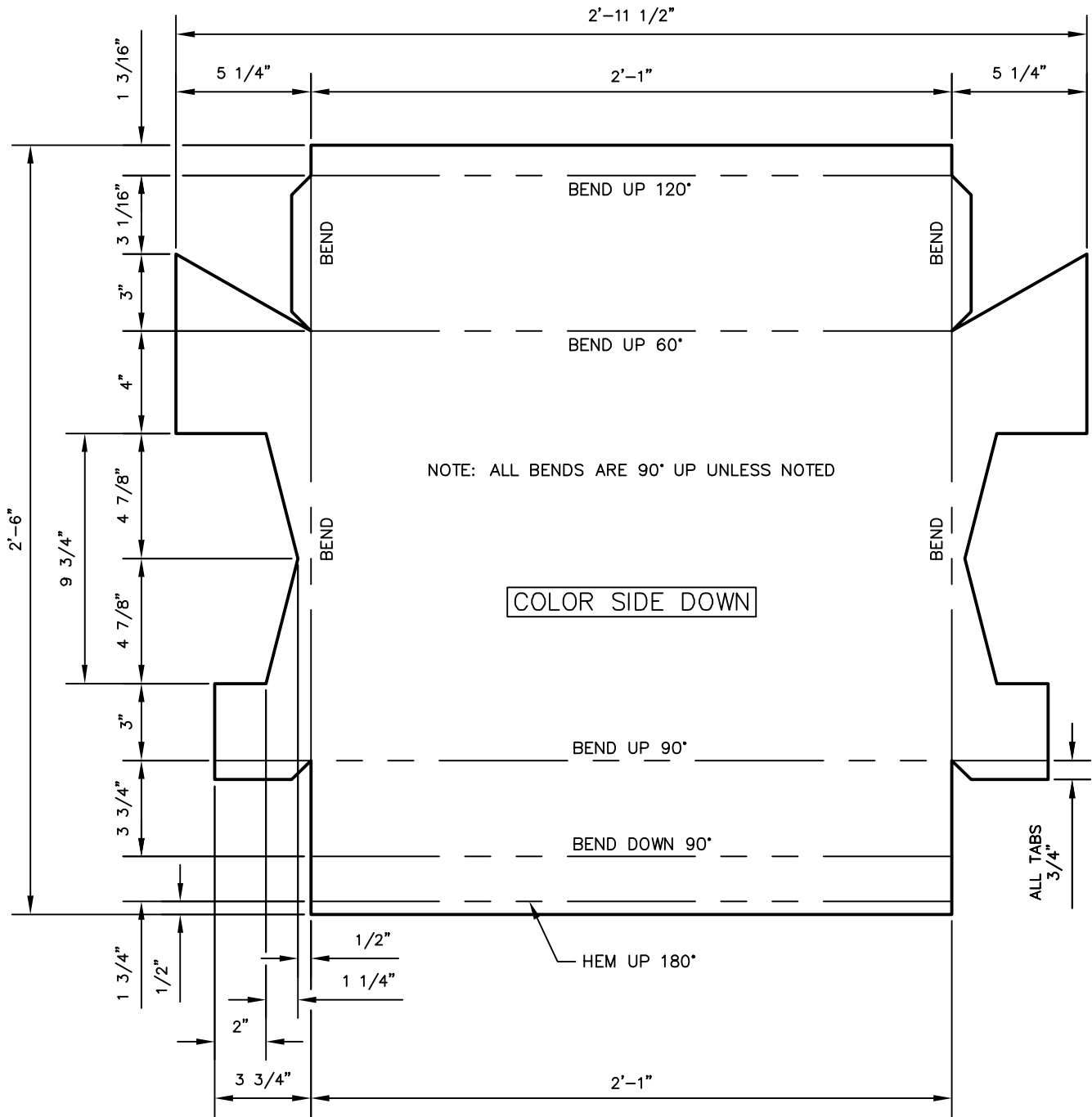

PANEL PROFILES	GAUGE
MAXIMA 1.5"	24
MAXIMA 2"	24
MAXIMA 3"	24
MAXIMA ADV	24
MASTERLOK-FS	24
MASTERLOK-90	24

## FLOATING PEAK BOX - PATTERN "A"

(FOR 2:12 TO 4:12 PITCH)

7-01-13 rev.  
 7-26-11 rev.  
 1-10-94

GIRTH: 2'-6" X 2'-11 1/2"  
 BENDS: 90° AND AS SPECIFIED

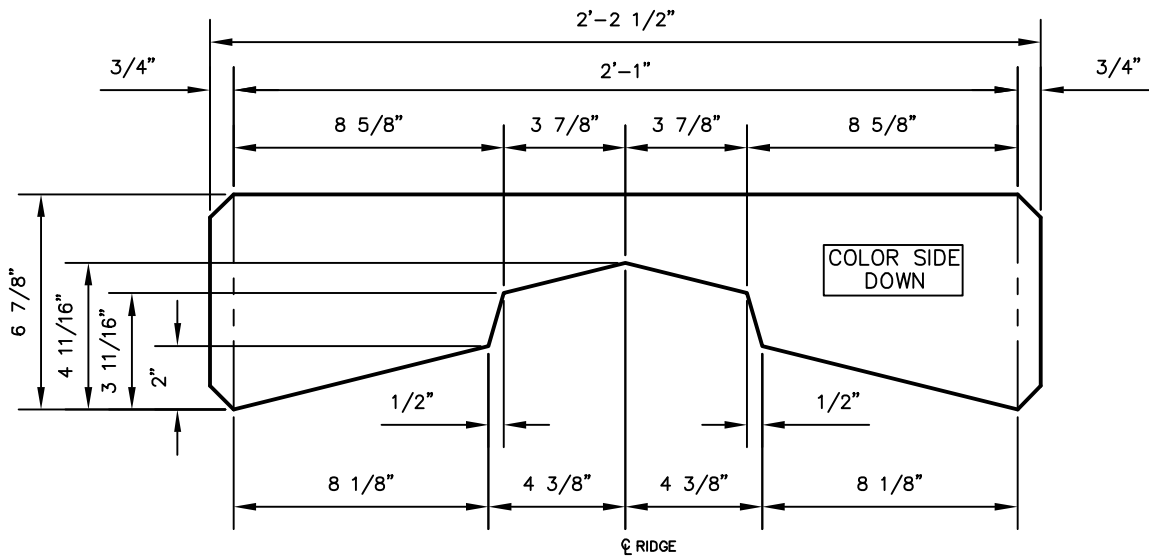

## FLOATING PEAK BOX - PATTERN "B"

(FOR 2:12 TO 4:12 PITCH)

PANEL PROFILES	GAUGE
MAXIMA 1.5"	24
MAXIMA 2"	24
MAXIMA 3"	24
MAXIMA ADV	24
MASTERLOK-FS	24
MASTERLOK-90	24

7-01-13 rev.  
7-26-11 rev.  
4-17-02

GIRTH: 6 7/8" X 2'-2 1/2"  
BENDS: UP 90°

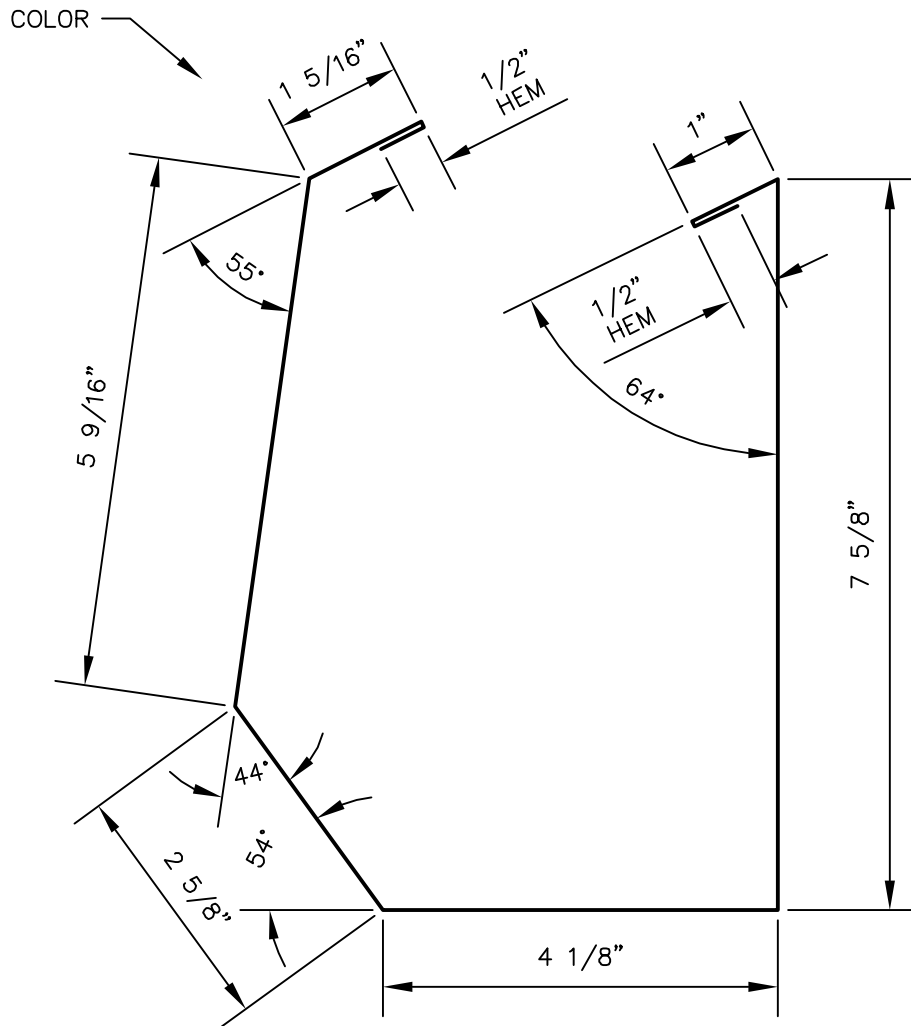

**GUTTER (6:12 PITCH)**

PANEL PROFILES	GAUGE
MAXIMA 2"	24

7-01-13 rev.  
9-27-11 rev.  
7-5-02

GIRTH:  $23 \frac{1}{4}$ "  
BENDS:  $90^\circ$  UNLESS NOTED

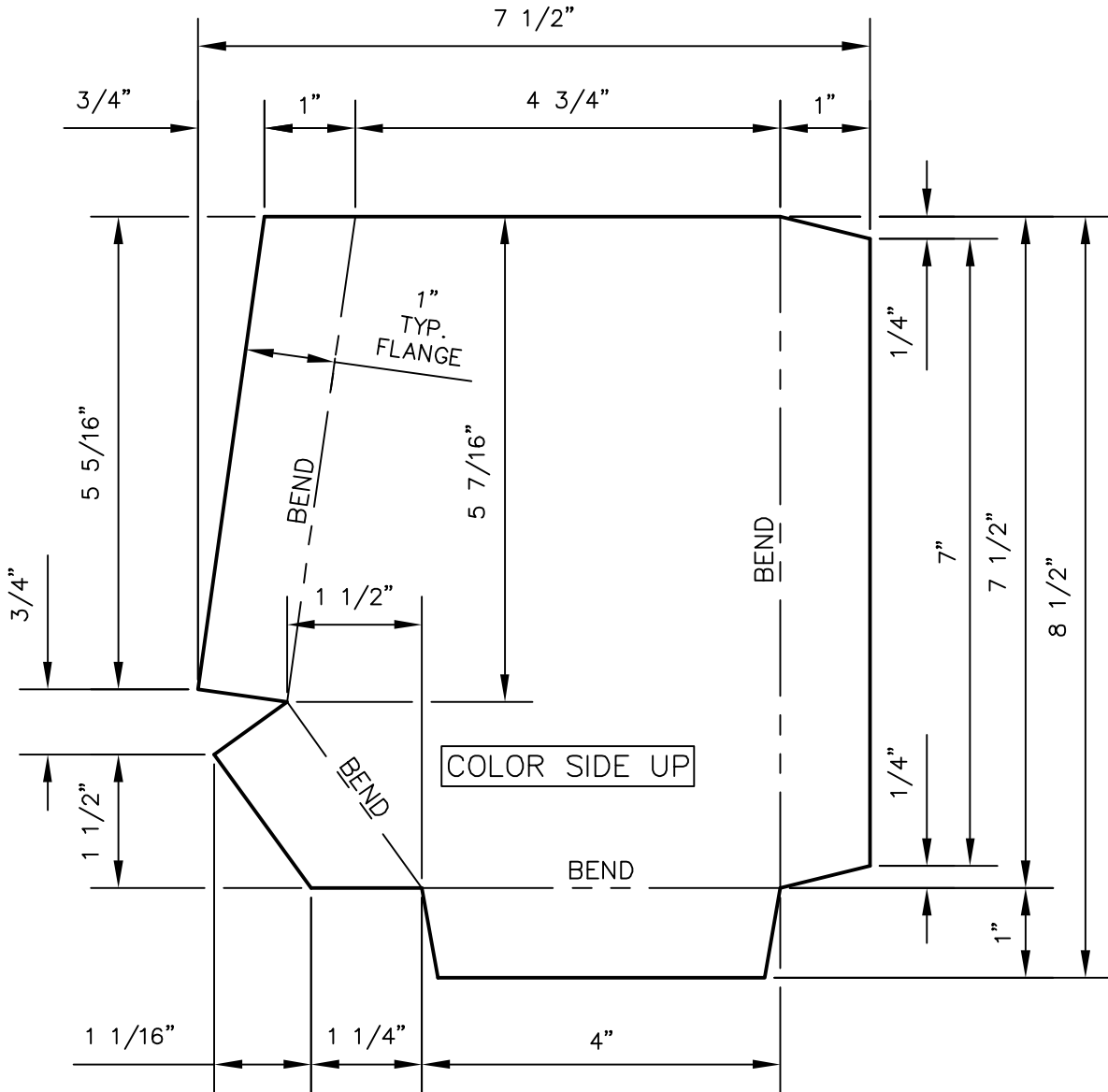

### GUTTER END CAP (6:12 PITCH) - PATTERN

(R.H. SHOWN - L.H. OPP.)

PANEL PROFILES	GAUGE
MAXIMA 2"	24 or 26

8-22-13 rev.  
 9-27-11 rev.  
 7-5-02

GIRTH: 7 1/2" X 8 1/2"  
 BENDS: 90° UNLESS NOTED  
 FINISH DETAIL: MXTW-0161A

111A

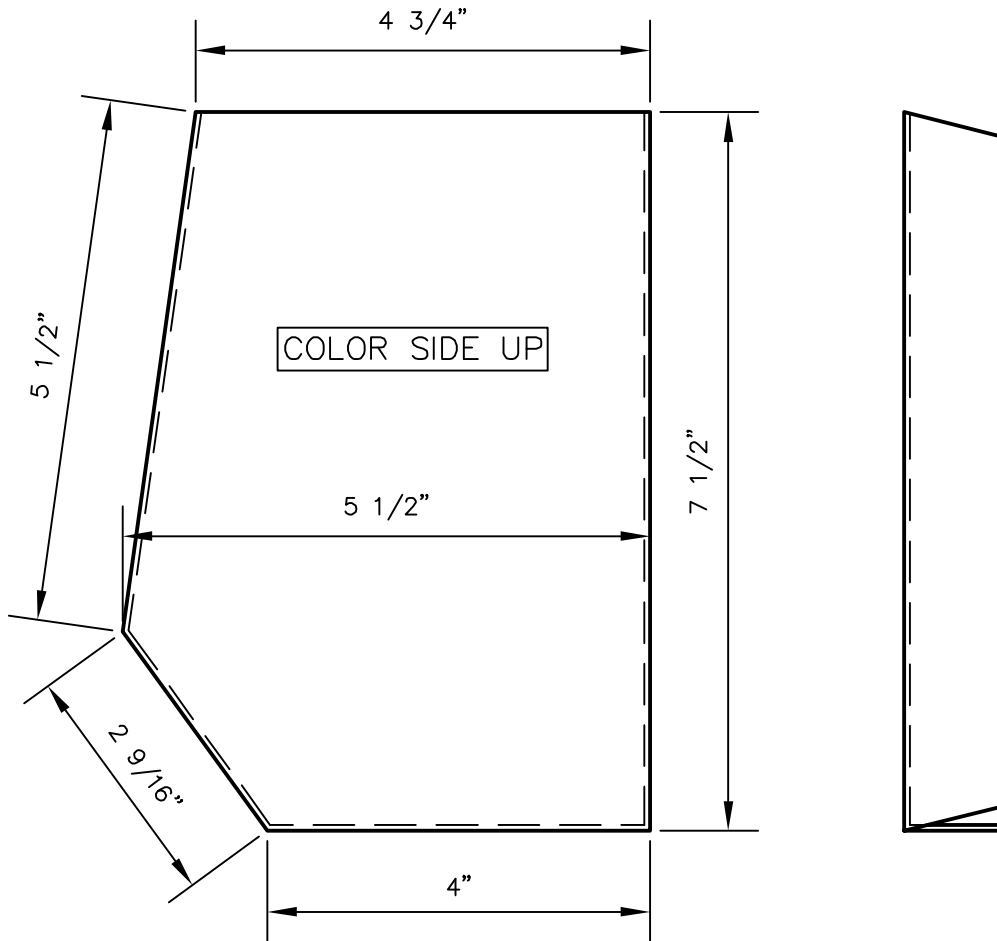

**GUTTER END CAP (6:12 PITCH) - FINISHED**  
(R.H. SHOWN - L.H. OPP.)

PANEL PROFILES	GAUGE
MAXIMA 2"	24 or 26

8-22-13 rev.  
9-27-11 rev.  
7-5-02

GIRTH: SEE PATTERN MXTW-0161  
BENDS: SEE PATTERN MXTW-0161

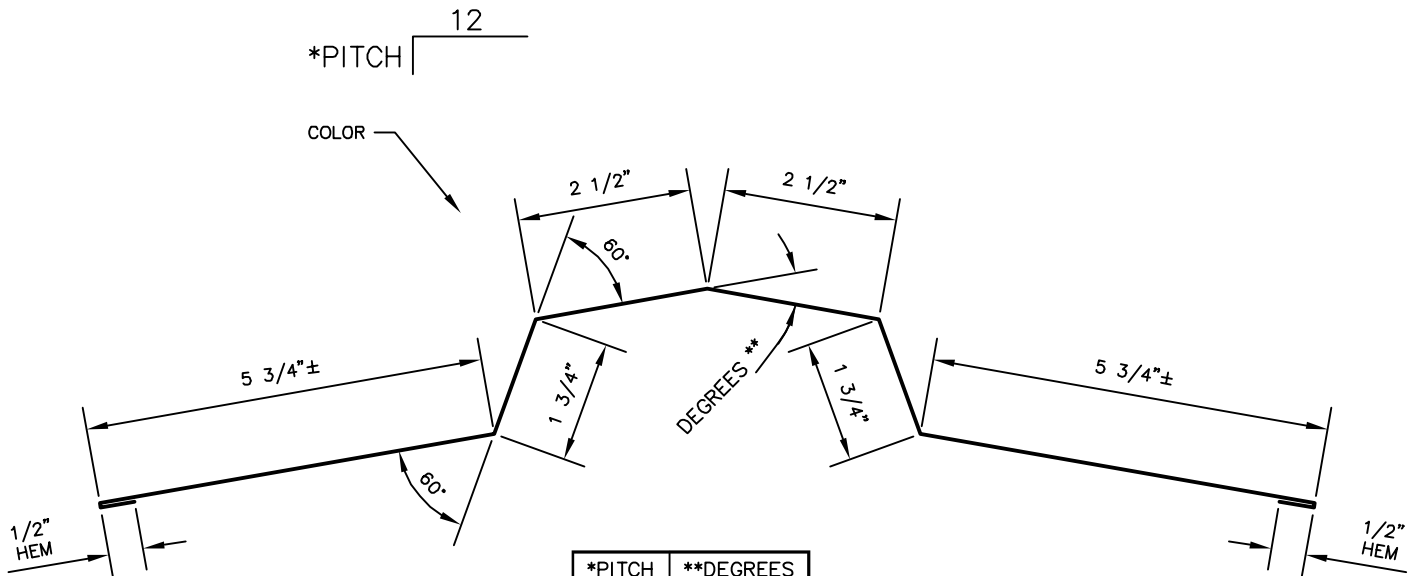

*PITCH	**DEGREES
1:12	7°
2:12	14°
3:12	20°
4:12	27°
5:12	33°
6:12	39°
7:12	45°
8:12	51°
9:12	57°
10:12	63°
11:12	69°
12:12	75°

### FLOATING HIP TRIM

PANEL PROFILES	GAUGE
MAXIMA 1.5"	24
MAXIMA 2"	24
MAXIMA 3"	24
MAXIMA ADV	24
MASTERLOK-FS	24
MASTERLOK-90	24

7-01-13 rev.  
 7-19-11 rev.  
 5-19-04

GIRTH: 21"  
 BENDS: 90° UNLESS SPECIFIED



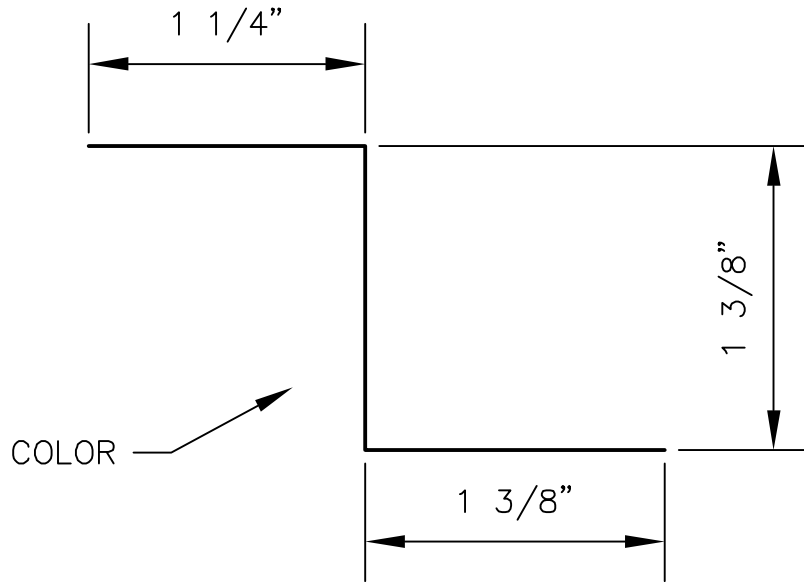

**ZEE CLOSURE**  
(FOR MAXIMA 1.5" PANEL ONLY)

PANEL PROFILES	GAUGE
MAXIMA 1.5"	24

7-01-13 rev.  
10-12-11 rev.  
12-16-10 rev.  
7-05-05

GIRTH: 4"  
BENDS: 90°

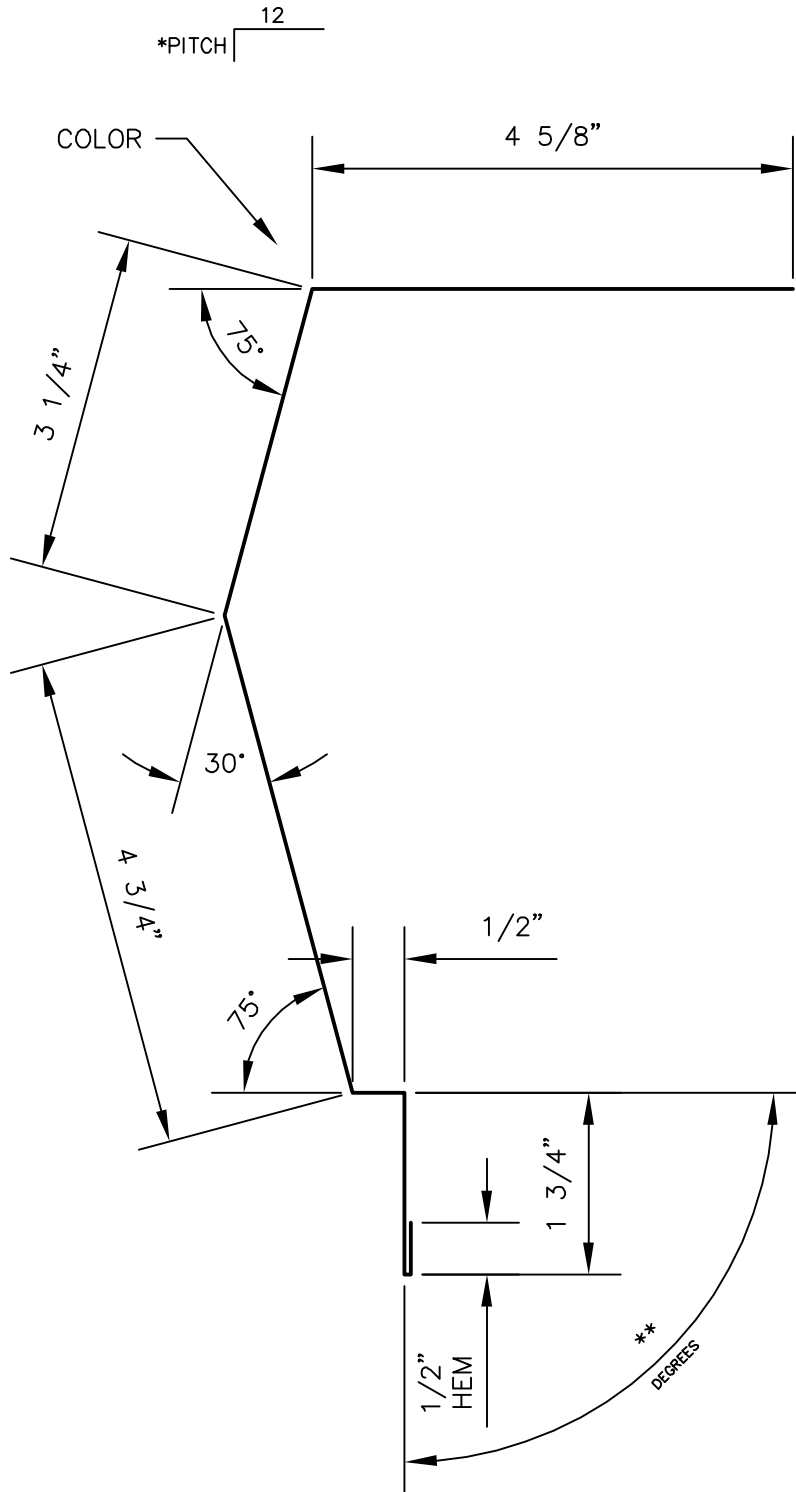

*PITCH	**DEGREES
1:12	95°
2:12	99°
3:12	103°
4:12	108°

**SCULPTURED EAVE TRIM**

PANEL PROFILES	GAUGE
MAXIMA 1.5"	24

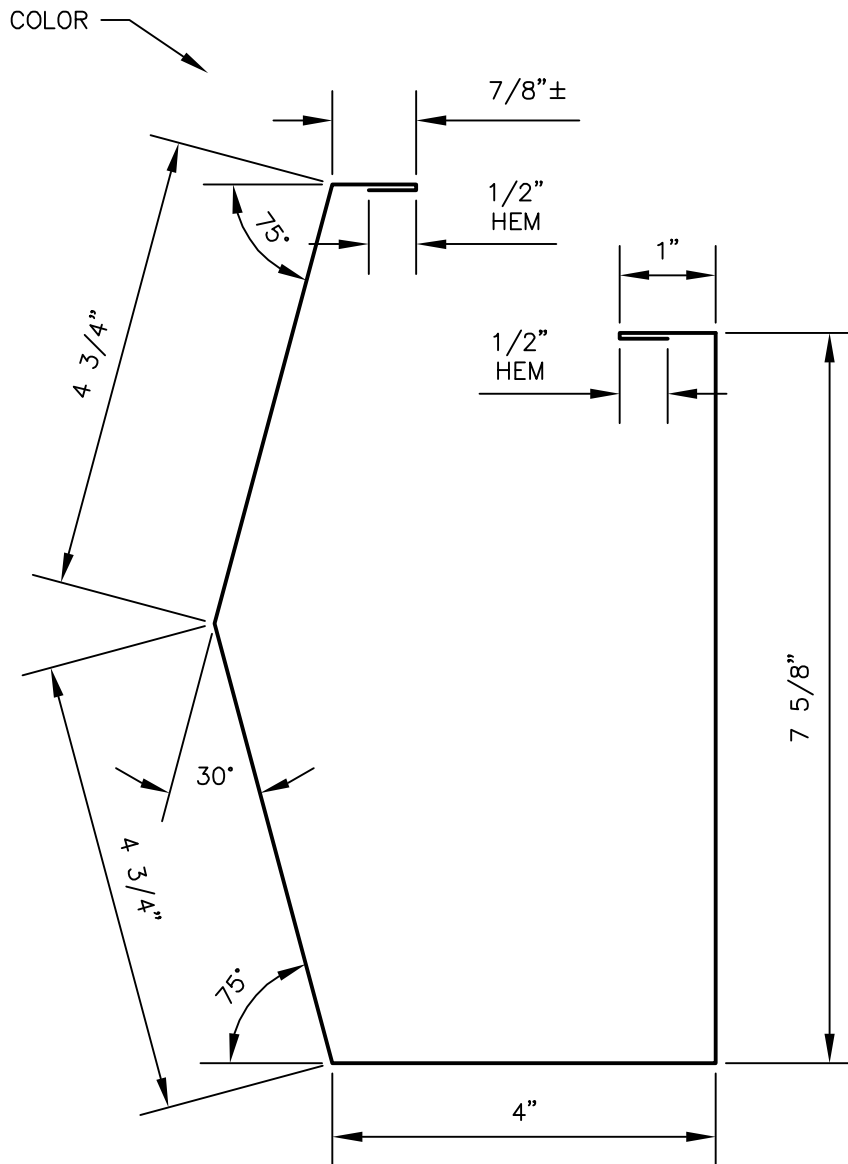

### GUTTER (UP TO 2:12 PITCH)

(R.H. SHOWN - L.H. OPP.)

PANEL PROFILES	GAUGE
MAXIMA 1.5"	24

7-01-13 rev.  
 9-27-11 rev.  
 1-15-07 rev.  
 7-05-05

GIRTH: 24"  
 BENDS: 90° UNLESS NOTED

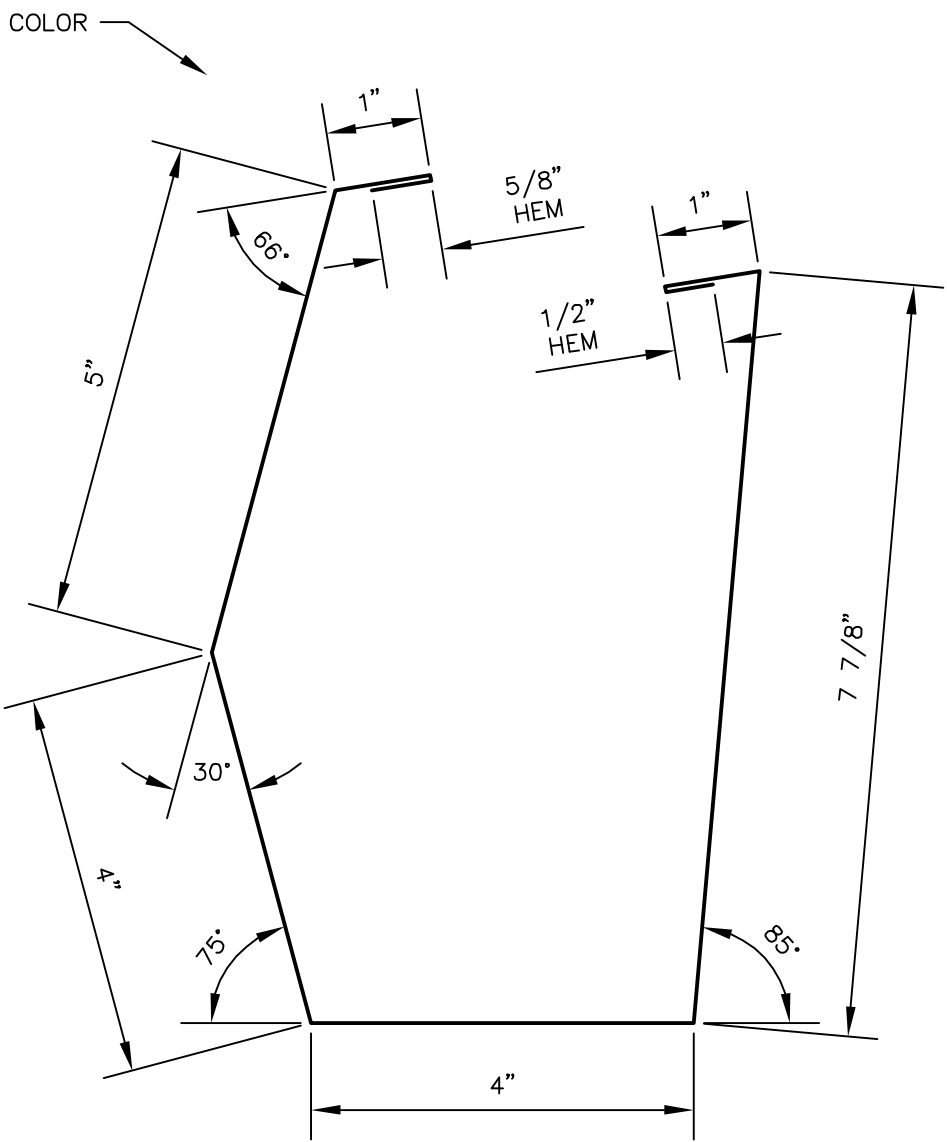

### GUTTER (2:12 TO 4:12 PITCH)

(R.H. SHOWN - L.H. OPP.)

PANEL PROFILES	GAUGE
MAXIMA 1.5"	24

7-01-13 rev.  
9-27-11 rev.  
1-15-07 rev.  
7-05-05

GIRTH: 24"  
BENDS: 90° UNLESS NOTED

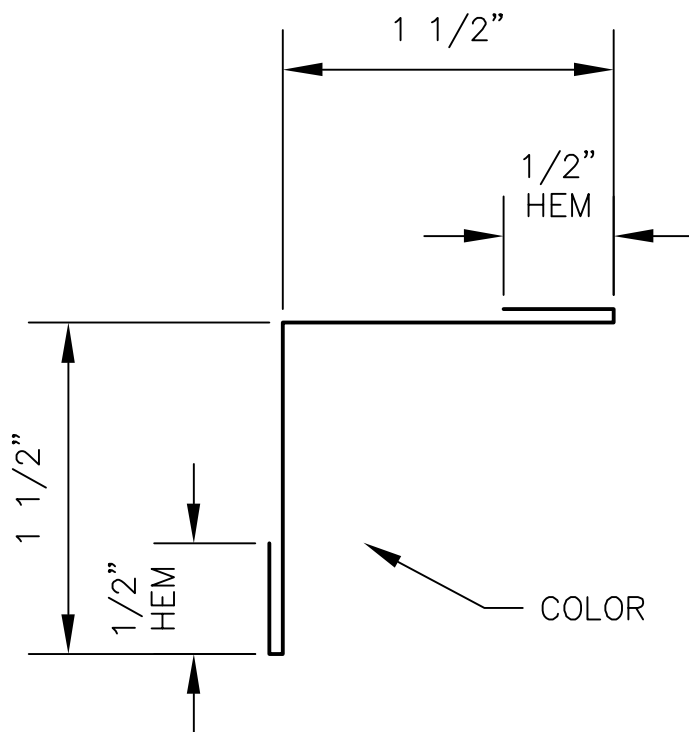

ANGLE TRIM

PANEL PROFILES	GAUGE
MAXIMA 1.5"	24
MAXIMA 2"	24
MAXIMA 3"	24
MAXIMA ADV	24

7-01-13 rev.  
 10-12-11 rev.  
 9-24-10

GIRTH: 4"  
 BENDS: 90°

193A

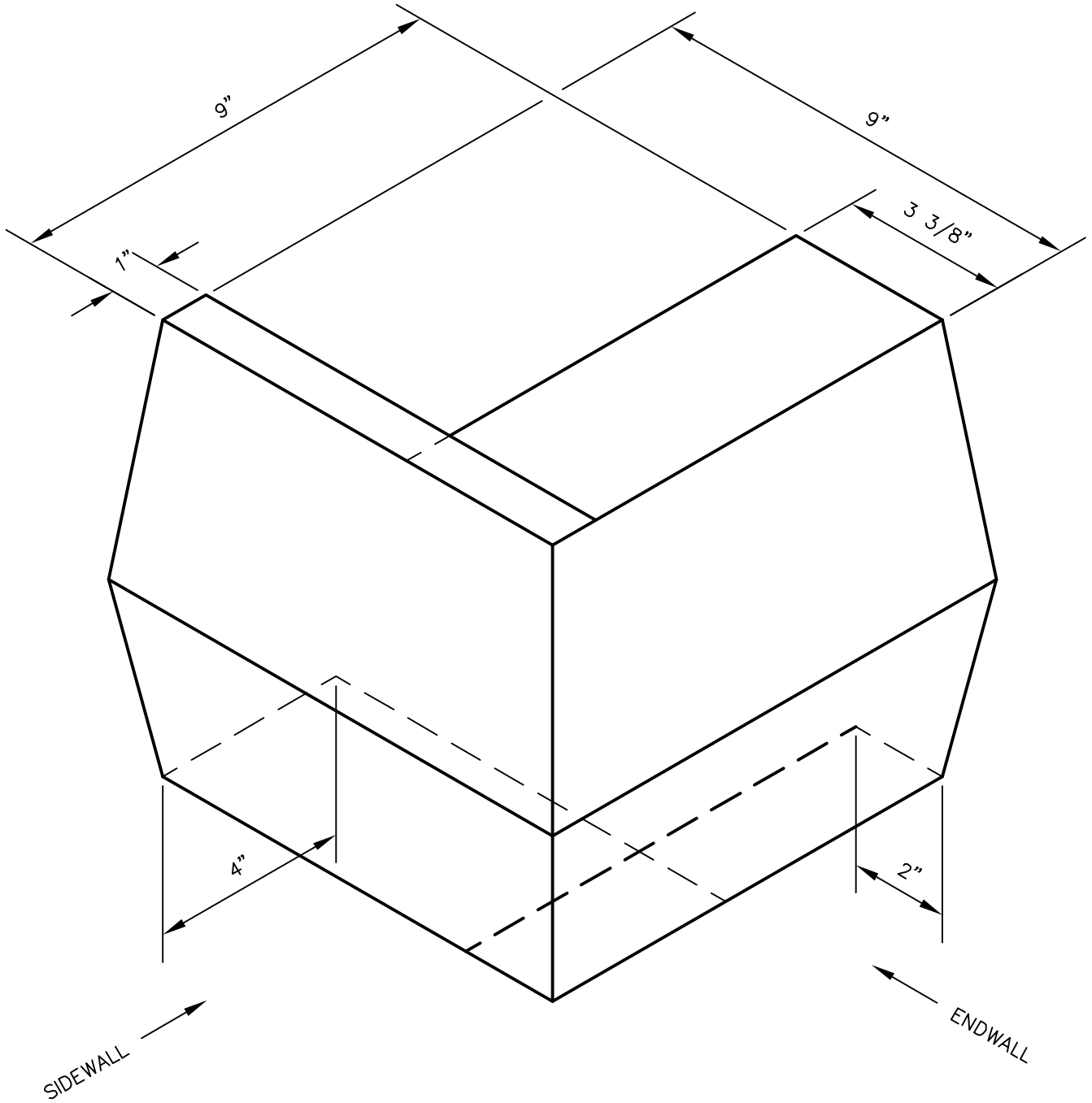

PANEL PROFILES	GAUGE
MAXIMA 1.5"	24 or 26
MAXIMA 2"	24 or 26
MAXIMA 3"	24 or 26
MAXIMA ADV	24 or 26
MASTERLOK-90	24 or 26
MASTERLOK-FS	24 or 26

## OUTSIDE CORNER BOX - FINISHED

(RIGHT HAND SHOWN)

(LEFT HAND OPP.)

(1/2:12 - 2:12 PITCHES)

6-6-18 rev.  
8-26-13 rev.  
3-16-94

GIRTH: SEE PATTERN MXTW-0172 & MXTW-0173  
BENDS: SEE PATTERN MXTW-0172 & MXTW-0173

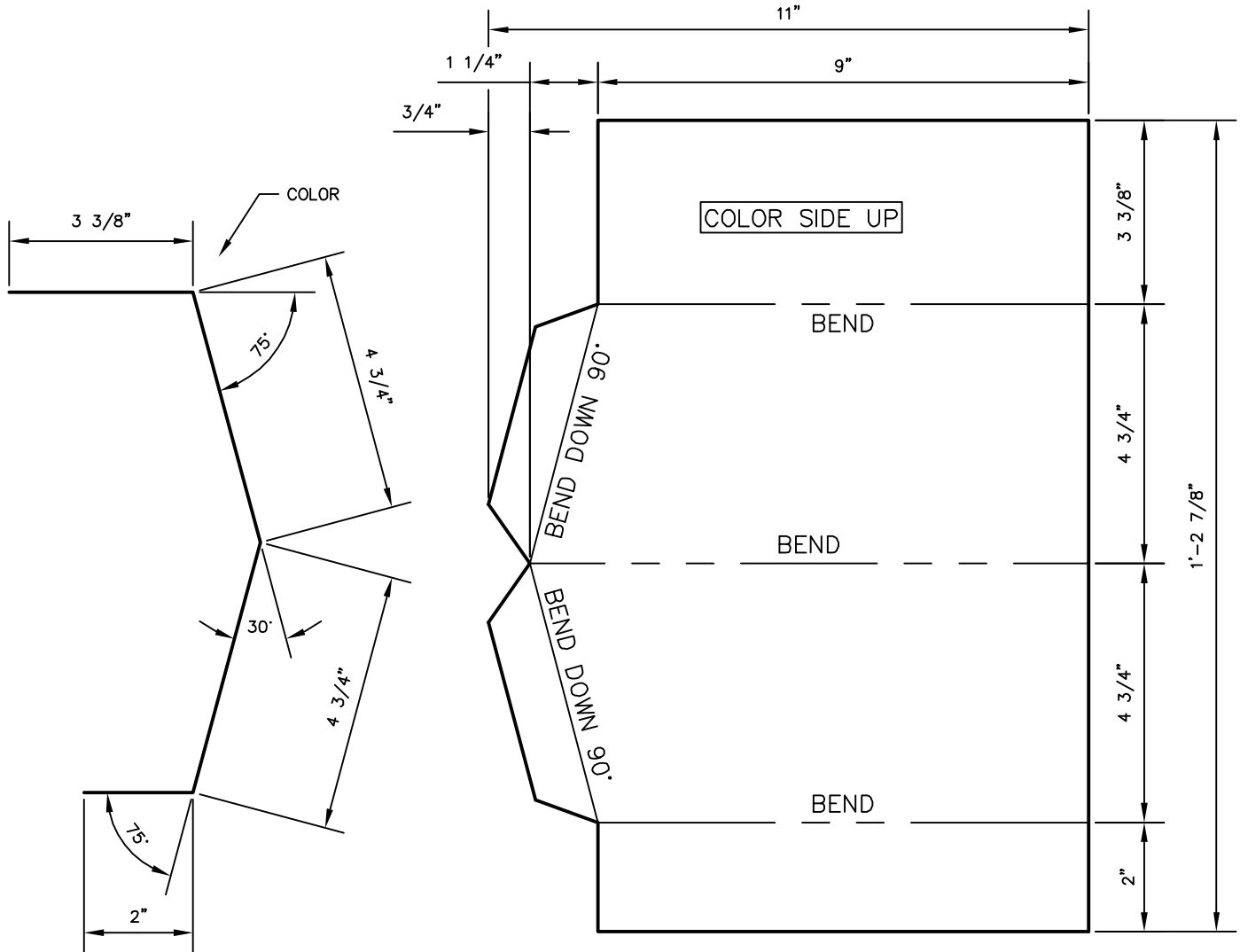

## OUTSIDE CORNER BOX - RAKE PATTERN

(FOR UP TO 2:12 PITCH)  
 (ASSEMBLE 1 R.H. & 1 L.H.)  
 (RIGHT HAND SHOWN - LEFT HAND OPP.)

PANEL PROFILES	GAUGE
MAXIMA 1.5"	24 or 26
MAXIMA 2"	24 or 26
MAXIMA 3"	24 or 26
MAXIMA ADV	24 or 26
MASTERLOK-90	24 or 26
MASTERLOK-FS	24 or 26

6-6-18 rev.  
 8-26-13 rev.  
 3-16-94

GIRTH: 1'-2 7/8" X 11"  
 BENDS: DOWN 90° AND AS SPECIFIED

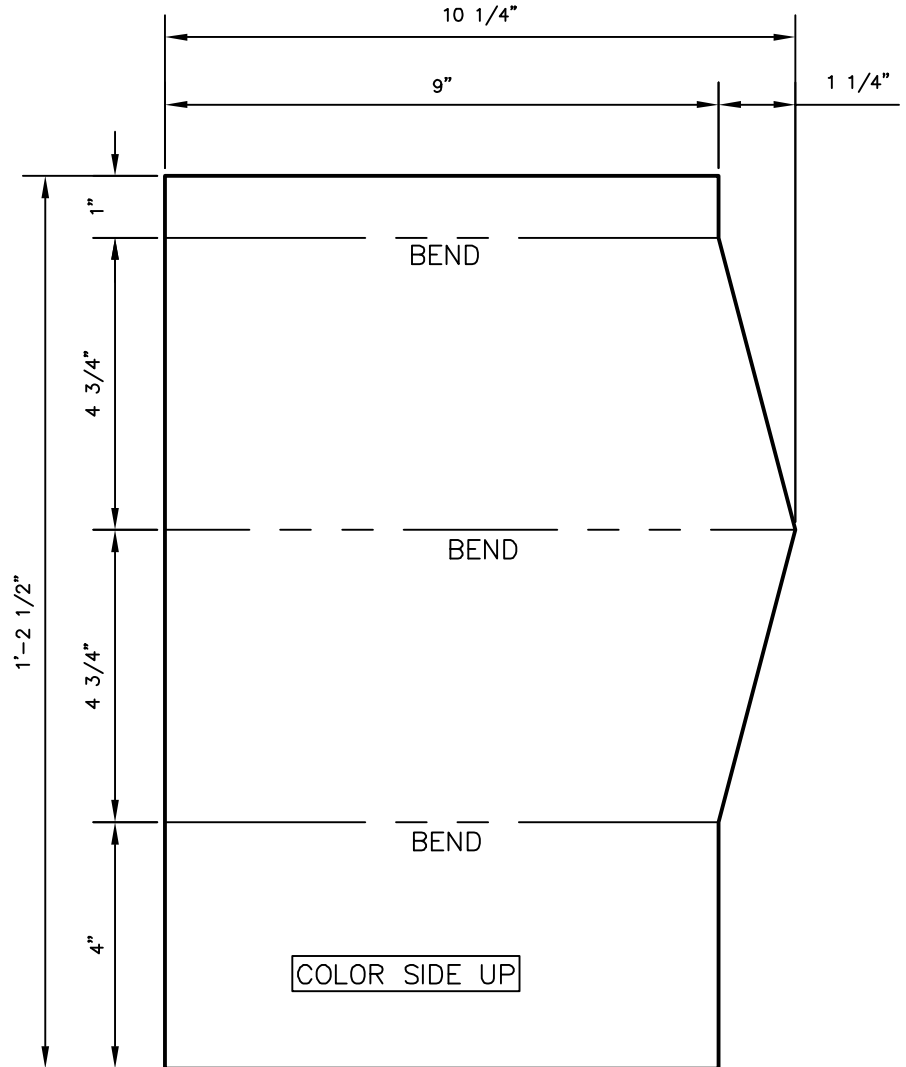
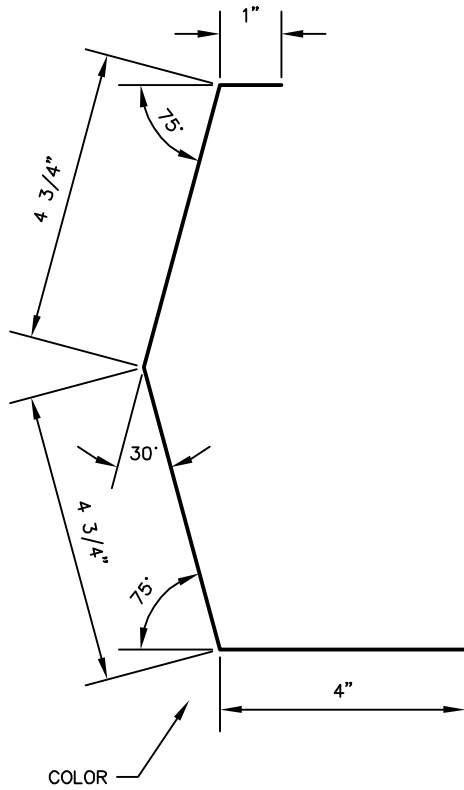

## OUTSIDE CORNER BOX - EAVE PATTERN

(FOR UP TO 2:12 PITCH)  
 (ASSEMBLE 1 R.H. & 1 L.H.)  
 (RIGHT HAND SHOWN - LEFT HAND OPP.)

PANEL PROFILES	GAUGE
MAXIMA 1.5"	24 or 26
MAXIMA 2"	24 or 26
MAXIMA 3"	24 or 26
MAXIMA ADV	24 or 26
MASTERLOK-90	24 or 26
MASTERLOK-FS	24 or 26

6-6-18 rev.  
 8-26-13 rev.  
 3-16-94

GIRTH: 10 1/4" X 1'-2 1/2"  
 BENDS: AS SPECIFIED



204A



PANEL PROFILES	GAUGE
MAXIMA 1.5"	24 or 26
MAXIMA 2"	24 or 26
MAXIMA 3"	24 or 26
MAXIMA ADV	24 or 26
MASTERLOK-90	24 or 26
MASTERLOK-FS	24 or 26

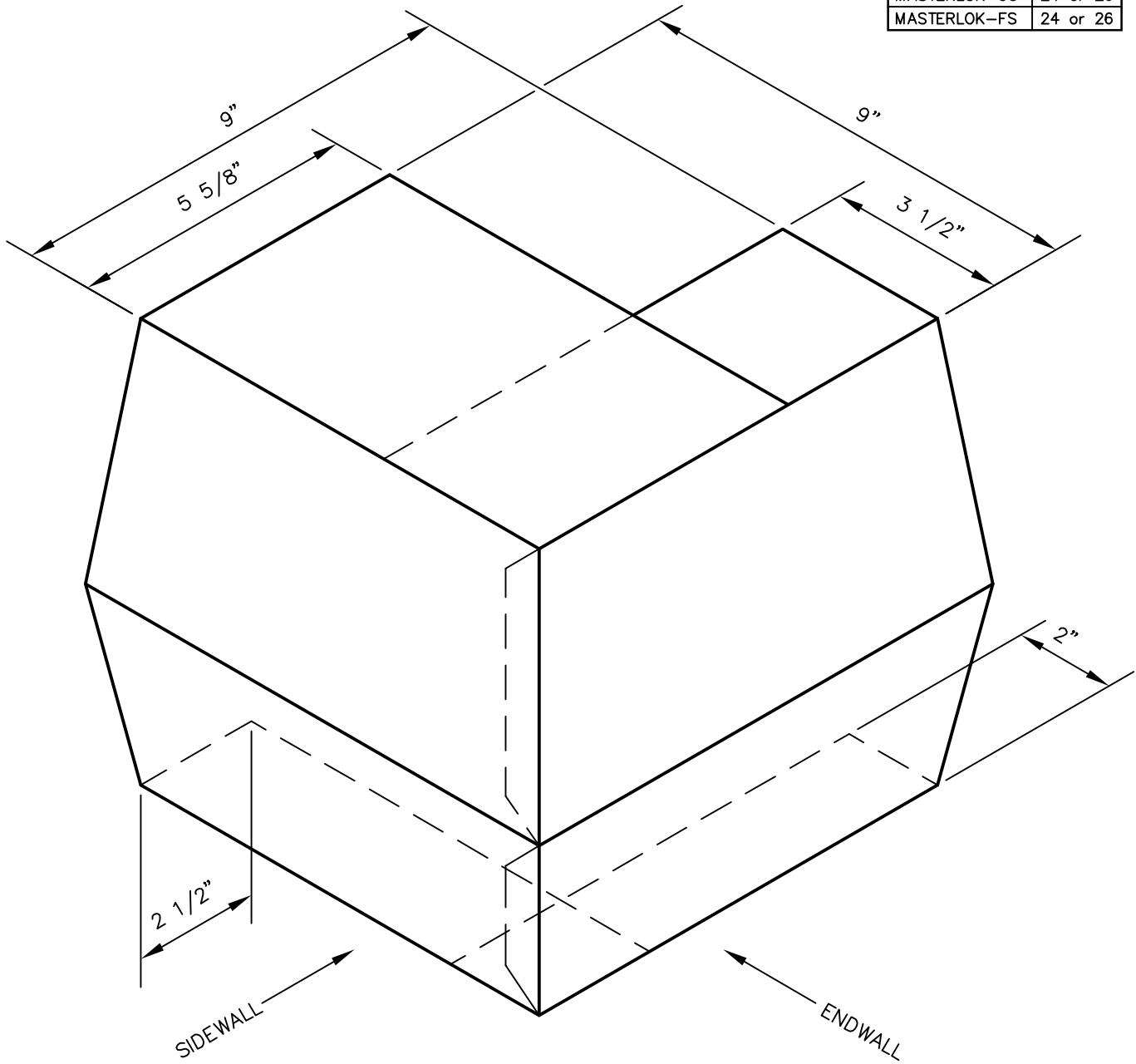

## HIGH-SIDE CORNER BOX - FINISHED

(RIGHT HAND SHOWN)  
(LEFT HAND OPP.)

4-6-15 rev.  
7-26-11 rev.  
5-9-06 rev.  
2-20-04

GIRTH: SEE PATTERN MXTW-0175 & MXTW-0176  
BENDS: SEE PATTERN MXTW-0175 & MXTW-0176

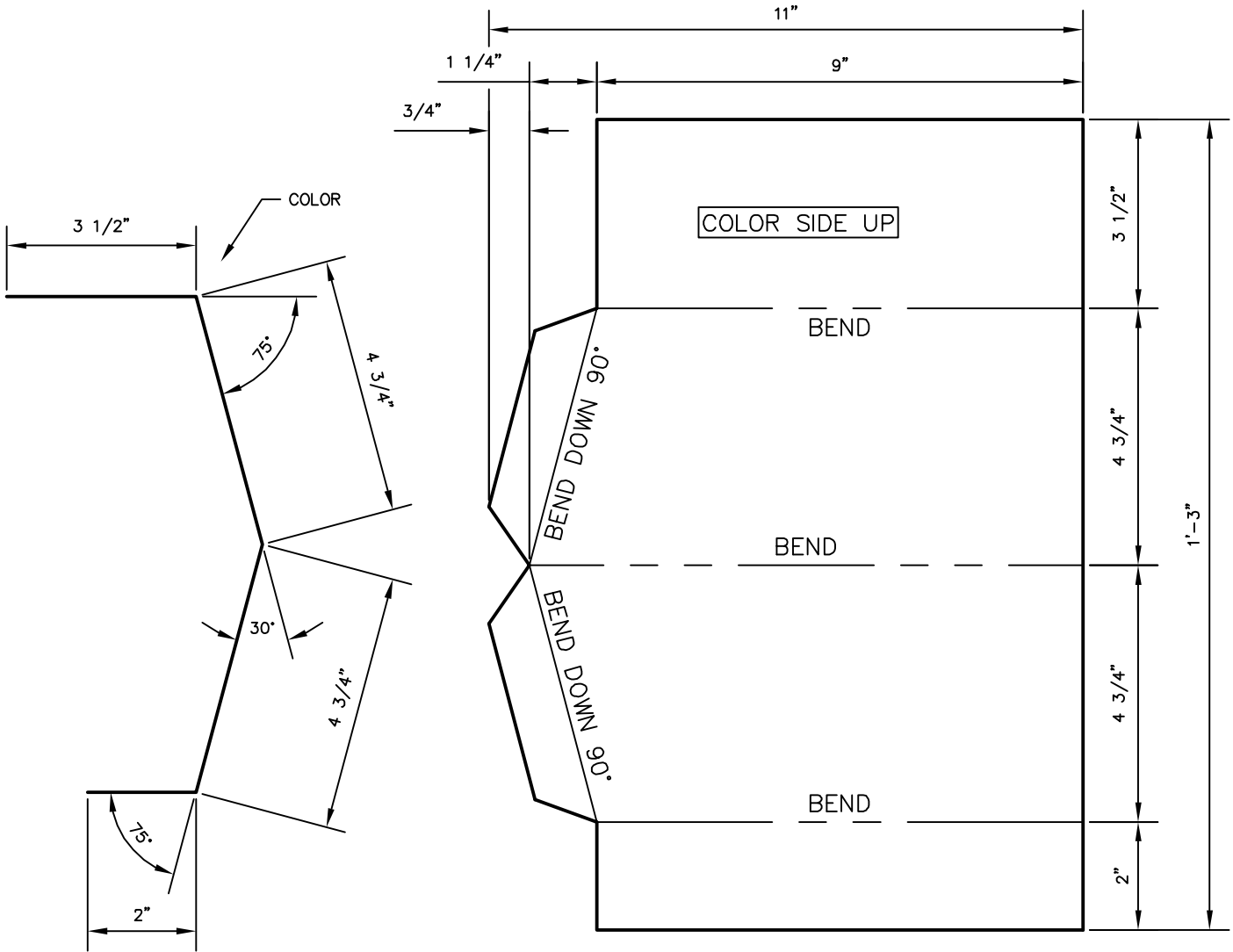

## HIGH-SIDE CORNER BOX - RAKE PATTERN

(ASSEMBLE 1 R.H. & 1 L.H.)  
 (RIGHT HAND SHOWN - LEFT HAND OPP.)

PANEL PROFILES	GAUGE
MAXIMA 1.5"	24 or 26
MAXIMA 2"	24 or 26
MAXIMA 3"	24 or 26
MAXIMA ADV	24 or 26
MASTERLOK-90	24 or 26
MASTERLOK-FS	24 or 26

4-6-15 rev.  
 7-26-11 rev.  
 3-16-94

GIRTH: 1'-3" X 11"  
 BENDS: DOWN 90° AND AS SPECIFIED



PANEL PROFILES	GAUGE
MAXIMA 1.5"	24 or 26
MAXIMA 2"	24 or 26
MAXIMA 3"	24 or 26
MAXIMA ADV	24 or 26
MASTERLOK-90	24 or 26
MASTERLOK-FS	24 or 26

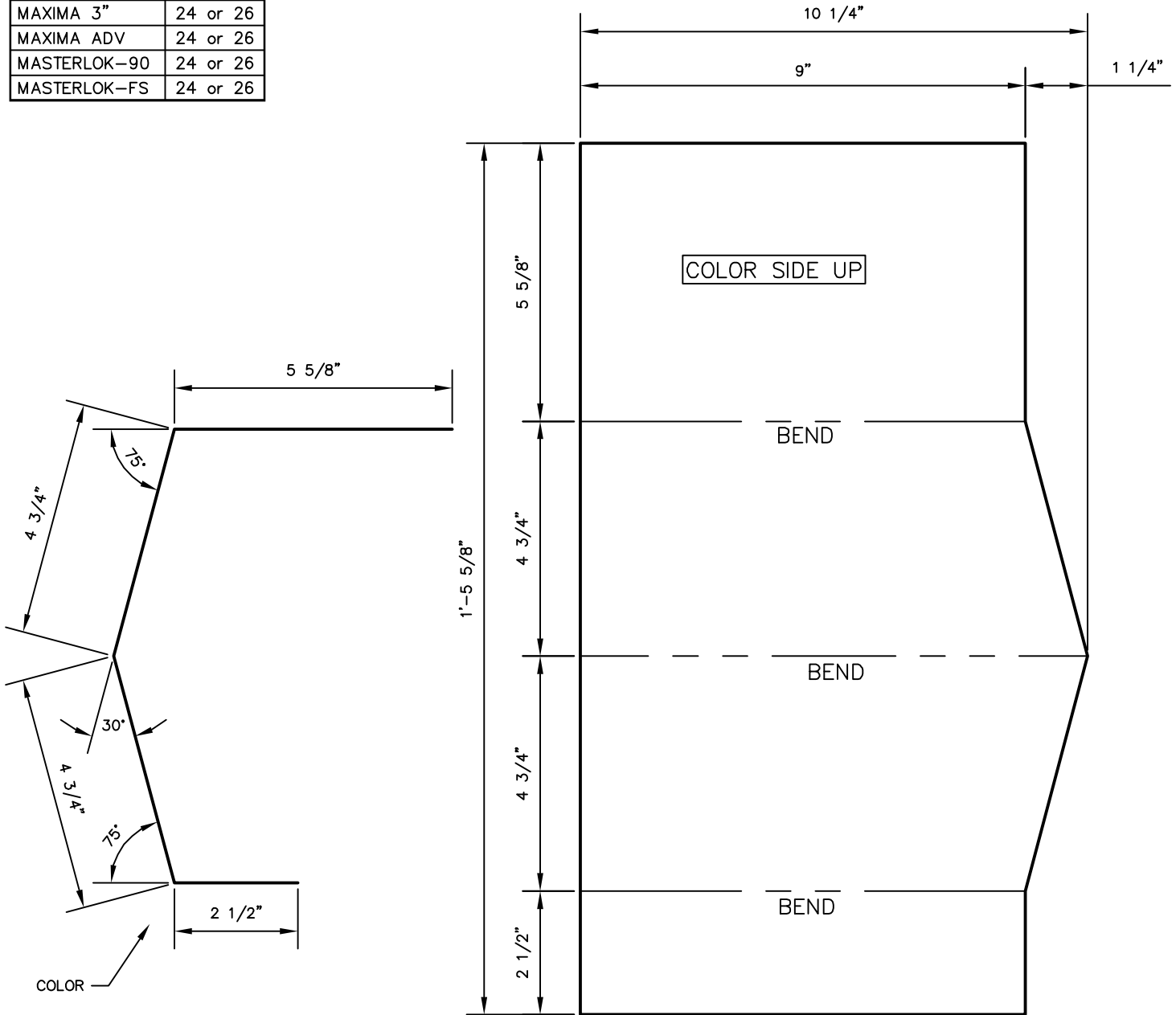

## HIGH-SIDE CORNER BOX - EAVE PATTERN

(FOR UP TO 2:12 PITCH)  
 (ASSEMBLE 1 R.H. & 1 L.H.)  
 (RIGHT HAND SHOWN - LEFT HAND OPP.)

4-6-15 rev.  
 7-26-11 rev.  
 3-16-94

GIRTH: 10 1/4" X 1'-5 5/8"  
 BENDS: UP 90°

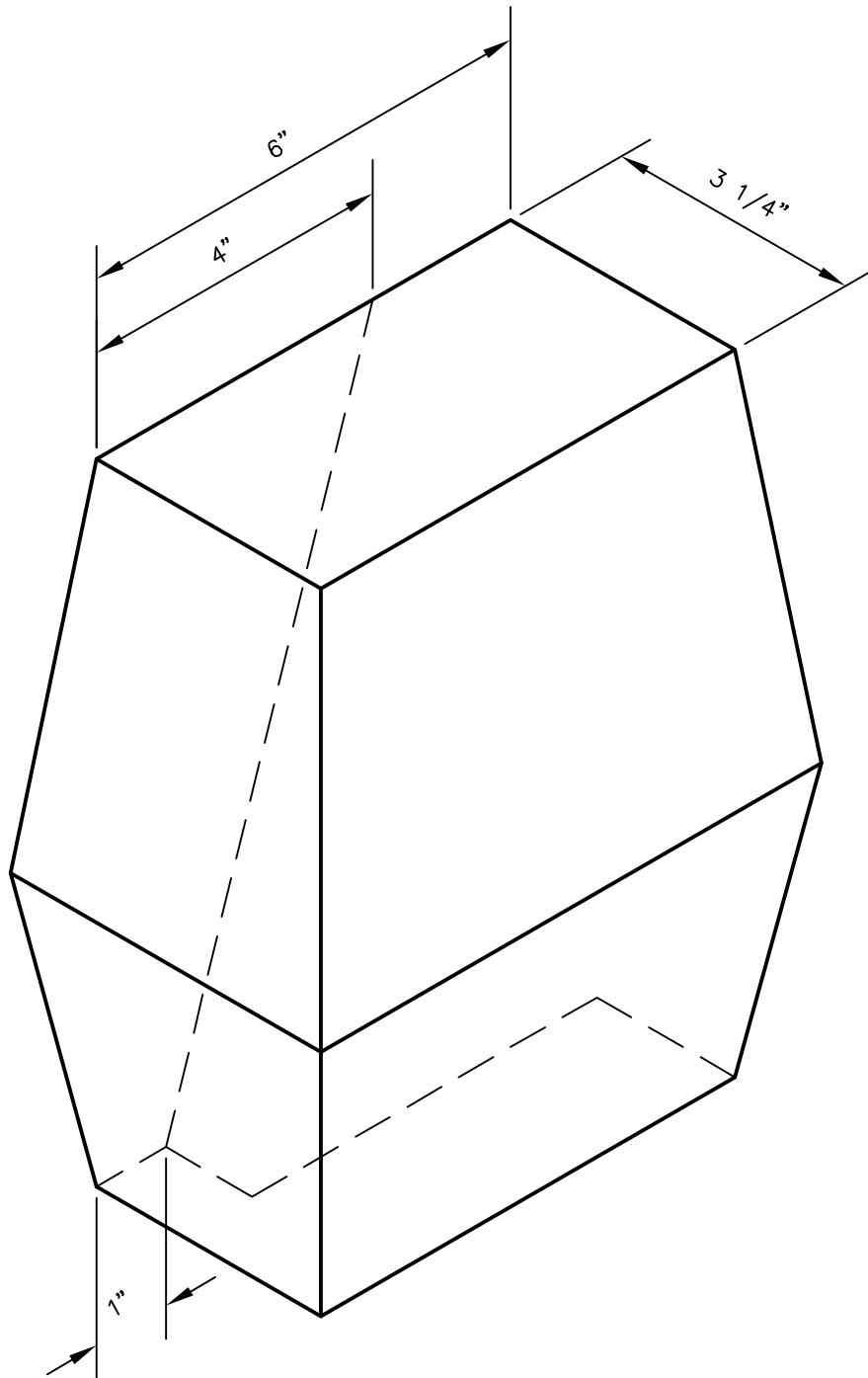

PANEL PROFILES	GAUGE
MAXIMA 1.5"	24 or 26
MAXIMA 2"	24 or 26
MAXIMA 3"	24 or 26
MAXIMA ADV	24 or 26
MASTERLOK-90	24 or 26
MASTERLOK-FS	24 or 26

**GUTTER CORNER BOX for SCULPTURED GUTTER - FINISHED**

(R.H. SHOWN - L.H. OPPTS.)  
 (FOR UP TO 4:12 PITCH)

4-20-15 rev.  
 7-29-11 rev.  
 5-09-06 rev.  
 1-03-94

GIRTH: SEE PATER: MXTW-0178  
 BENDS: SEE PATER: MXTW-0178

200B

200C

200D

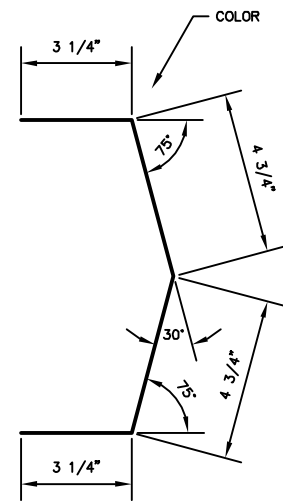

GIRTH: 8" X 1'-4"  
BENDS: AS SPECIFIED

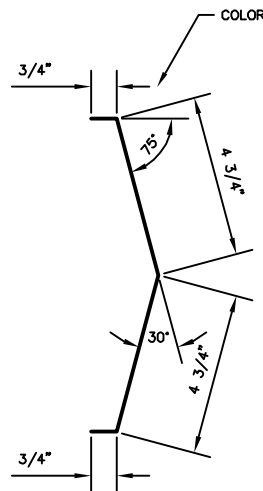
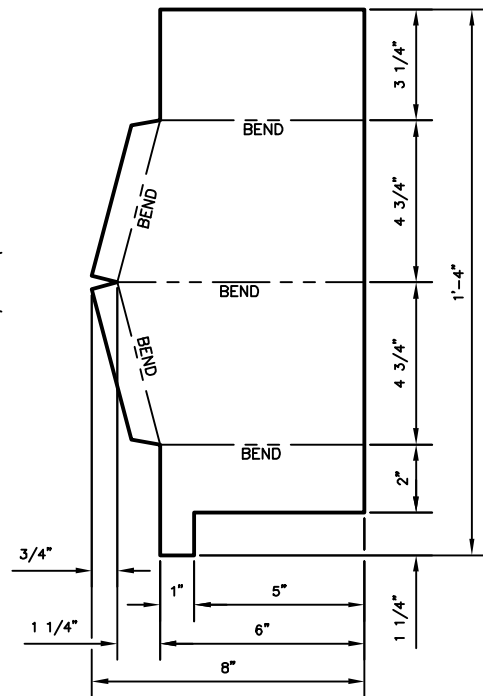

GIRTH: 4 1/2" X 11"  
BENDS: AS SPECIFIED

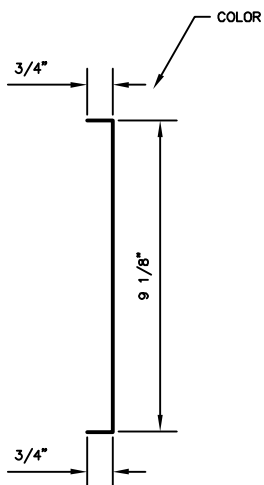
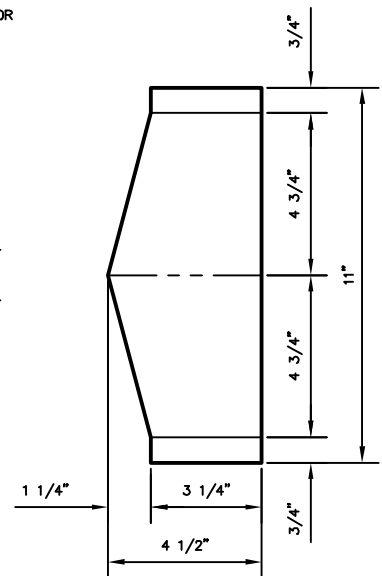

GIRTH: 6" X 10 5/8"  
BENDS: 90°

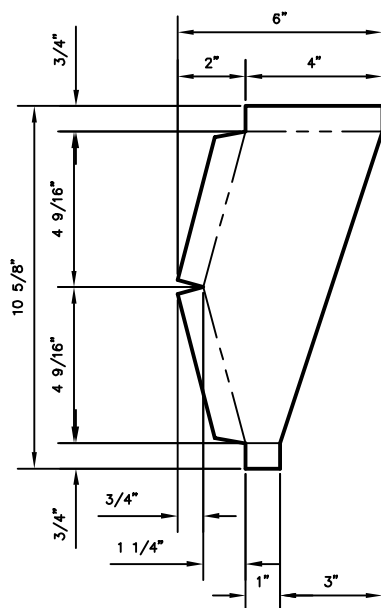

PANEL PROFILES	GAUGE
MAXIMA 1.5"	24 or 26
MAXIMA 2"	24 or 26
MAXIMA 3"	24 or 26
MAXIMA ADV	24 or 26
MASTERLOK-90	24 or 26
MASTERLOK-FS	24 or 26

## GUTTER CORNER BOX for SCULPTURED GUTTER - PATTERNS

(R.H. SHOWN - L.H. OPP.)  
(FOR UP TO 4:12 PITCH)

4-20-15 rev.  
7-29-11 rev.  
5-09-06 rev.  
1-03-94

SEE FINISHED: MXTW-0177

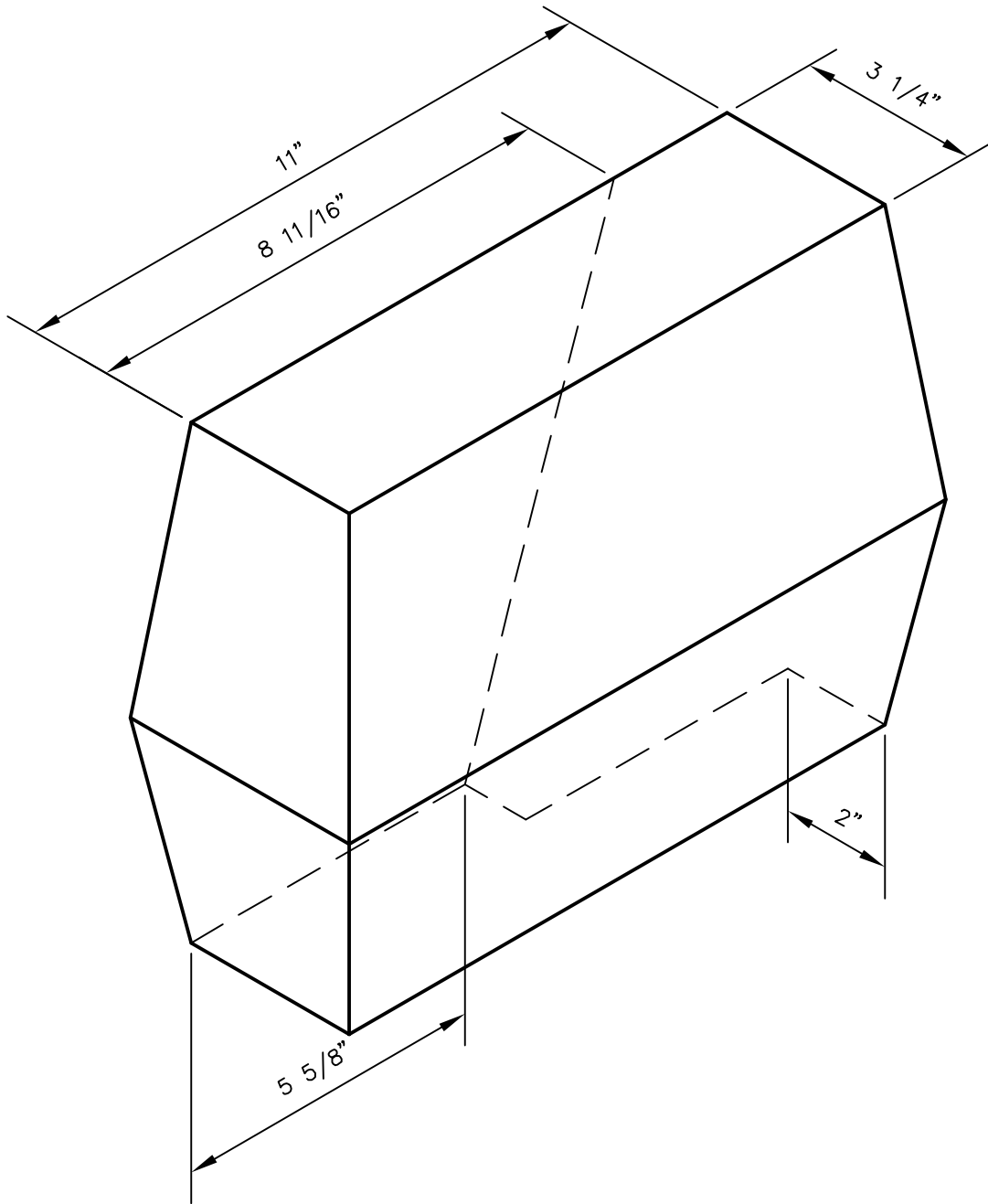

**GUTTER CORNER BOX for STANDARD GUTTER - FINISHED**

(RIGHT HAND SHOWN)  
 (LEFT HAND OPP.)  
 (2:12 - 4:12 PITCHES)

PANEL PROFILES	GAUGE
MAXIMA 1.5"	24 or 26
MAXIMA 2"	24 or 26
MAXIMA 3"	24 or 26
MAXIMA ADV	24 or 26
MASTERLOK-90	24 or 26
MASTERLOK-FS	24 or 26

6-6-18 rev.  
 4-20-15 rev.  
 3-17-94

GIRTH: SEE PATTERN MXTW-0180  
 BENDS: SEE PATTERN MXTW-0180

196B

196C

196D

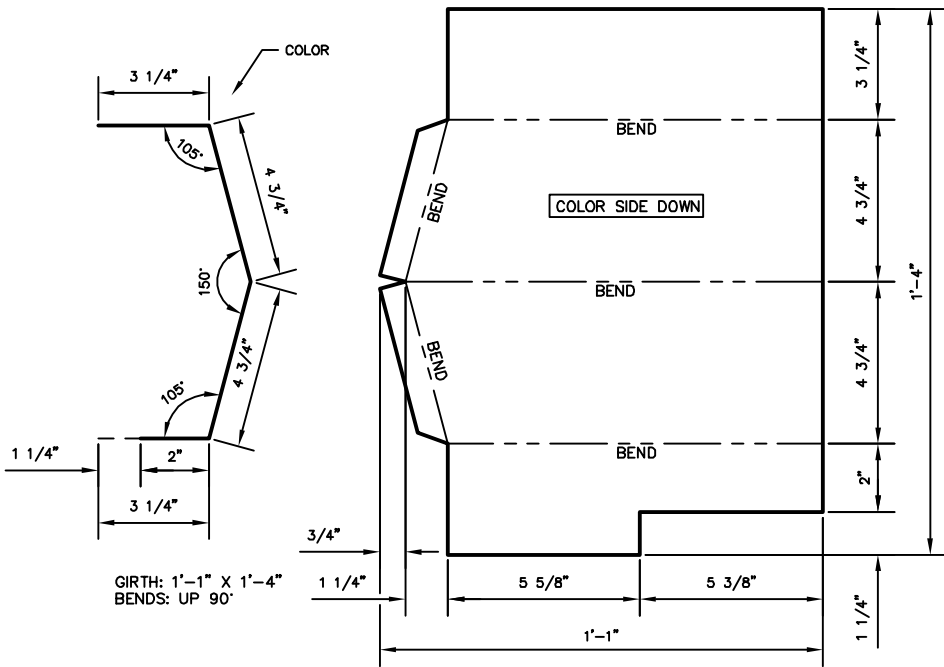

## GUTTER CORNER BOX for STANDARD GUTTER - PATTERN

(R.H. SHOWN - L.H. OPP.)  
(FOR 2:12 TO 4:12 PITCH)

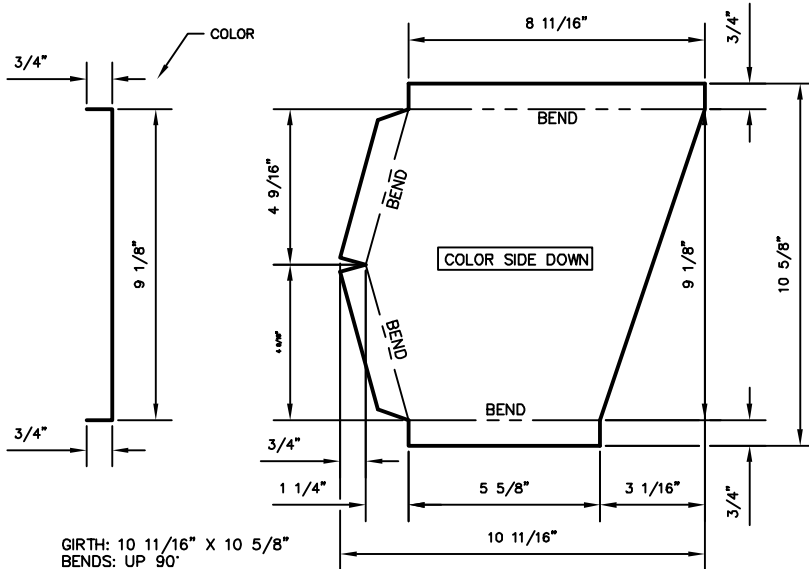
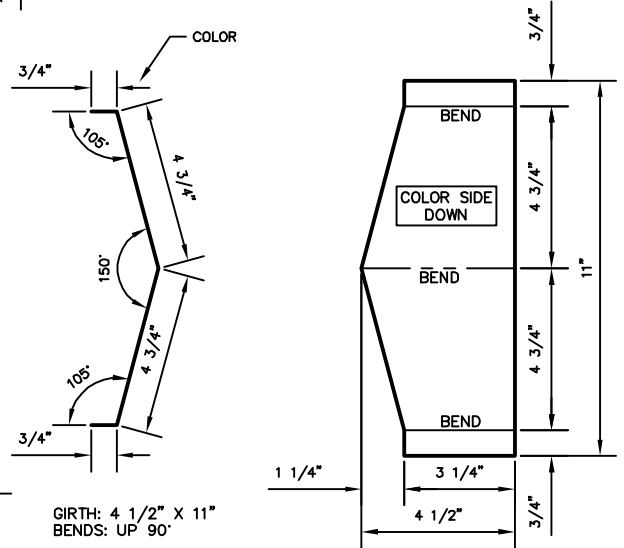

PANEL PROFILES	GAUGE
MASTERLOK-90	24 or 26
MASTERLOK-FS	24 or 26
MAXIMA 1.5"	24 or 26
MAXIMA 2"	24 or 26
MAXIMA 3"	24 or 26
MAXIMA ADV	24 or 26

6-6-18 rev.  
4-20-15 rev.  
7-29-11 rev.  
2-20-04

SEE FINISHED: MXTW-0179