

INDUSTRIAL TRIM INDEX

<u>DWG #:</u>	<u>DESCRIPTION:</u>	<u>IMAGE #:</u>
ITW-0101	Standard Gutter (1/2:12 to 2:12)	86
ITW-0102	Rake Trim	42
ITW-0103	Skylight Side Trim - UL90 (Multi-Rib Panel)	147
ITW-0104	Zee Flashing	266
ITW-0105	Mini Jamb / Header Cover	267
ITW-0106	Outside Angle Trim	268
ITW-0107	Inside Angle Trim	269
ITW-0108	Masonry Wainscoat Trim	270
ITW-0109	Rake Tie-In Trim - Endwall	66
ITW-0110	High-Side Tie-In Trim	13
ITW-0111	High Side Eave Trim	5
ITW-0112	Gutter Strap	115
ITW-0113	Sculptured Gutter	98
ITW-0114	Ridge Cap	73
ITW-0115	Eave Trim	22
ITW-0116	Head Trim	271
ITW-0117	Jamb Trim	272
ITW-0118	Inside Corner Trim - Multi-Rib	273
ITW-0119	Outside Corner Trim - Multi-Rib	274
ITW-0120	Base Trim	275
ITW-0121	Simple Base Trim	276
ITW-0123	Jamb - Head Cover	277
ITW-0124	Gutter End Cap - Pattern	104B
ITW-0125	Gutter End Cap - Standard (1/2:12 to 2:12)	104A
ITW-0130	Gutter End Cap - Sculptured (Finished)	112A
ITW-0131	Gutter End Cap - Sculptured (Pattern)	112B
ITW-0136	Outside Corner Box - 1/2:12 to 2:12 (Finished)	172A
ITW-0137	Outside Corner Box - Endwall (Pattern)	172B
ITW-0138	Outside Corner Box - Sidewall (Pattern)	172C
ITW-0141	Sculptured Eave Trim	33

<u>DWG #:</u>	<u>DESCRIPTION:</u>	<u>IMAGE #:</u>
ITW-0142	Rake Closure - Finished	170A
ITW-0143	Rake Closure - Pattern	170B
ITW-0144	High-Side Corner Box - Finished	175A
ITW-0145	High-Side Corner Box (Pattern) - Endwall	175B
ITW-0146	High-Side Corner Box (Pattern) - Sidewall	175C
ITW-0147	Fixed Peak Box Assembly 1:12	223A
ITW-0148	Fixed Peak Box 1:12	223B
ITW-0149	Outside Corner Trim - Multi-V	278
ITW-0151	Fixed Peak Box Assembly - 2:12	225A
ITW-0152	Fixed Peak Box 2:12	225B
ITW-0153	Fixed Peak Box Assembly - 3:12	227A
ITW-0154	Fixed Peak Box 3:12	227B
ITW-0155	Fixed Peak Box Assembly - 4:12	229A
ITW-0156	Fixed Peak Box 4:12	229B
ITW-0157	Fixed Peak Box Assembly - 5:12	231A
ITW-0158	Fixed Peak Box 5:12	231B
ITW-0159	Fixed Peak Box Assembly - 6:12	233A
ITW-0160	Fixed Peak Box 6:12	233B
ITW-0161	Variable Peak Box- Finished	237A
ITW-0162	Variable Peak Box - Pattern	237B
ITW-0163	Standard Gutter (for 2:12 to 4:12)	93
ITW-0164	Gutter End Cap (for 2:12 to 4:12)	158A
ITW-0165	Gutter End Cap - Pattern	158B
ITW-0166	Gutter Corner Box (for 2:12 to 4:12) - Finished	178A
ITW-0167	Gutter Corner Box (for 2:12 to 4:12) - Patterns	178B
		178C
		178D
ITW-0168	Fixed Peak Box 7:12 - Pattern	235B
ITW-0169	Fixed Peak Box 7:12 - Finished	235A
ITW-0170	Skylight Side Trim - UL90 (R-Panel)	354
ITW-0171	Alternate Wainscoat Trim	530

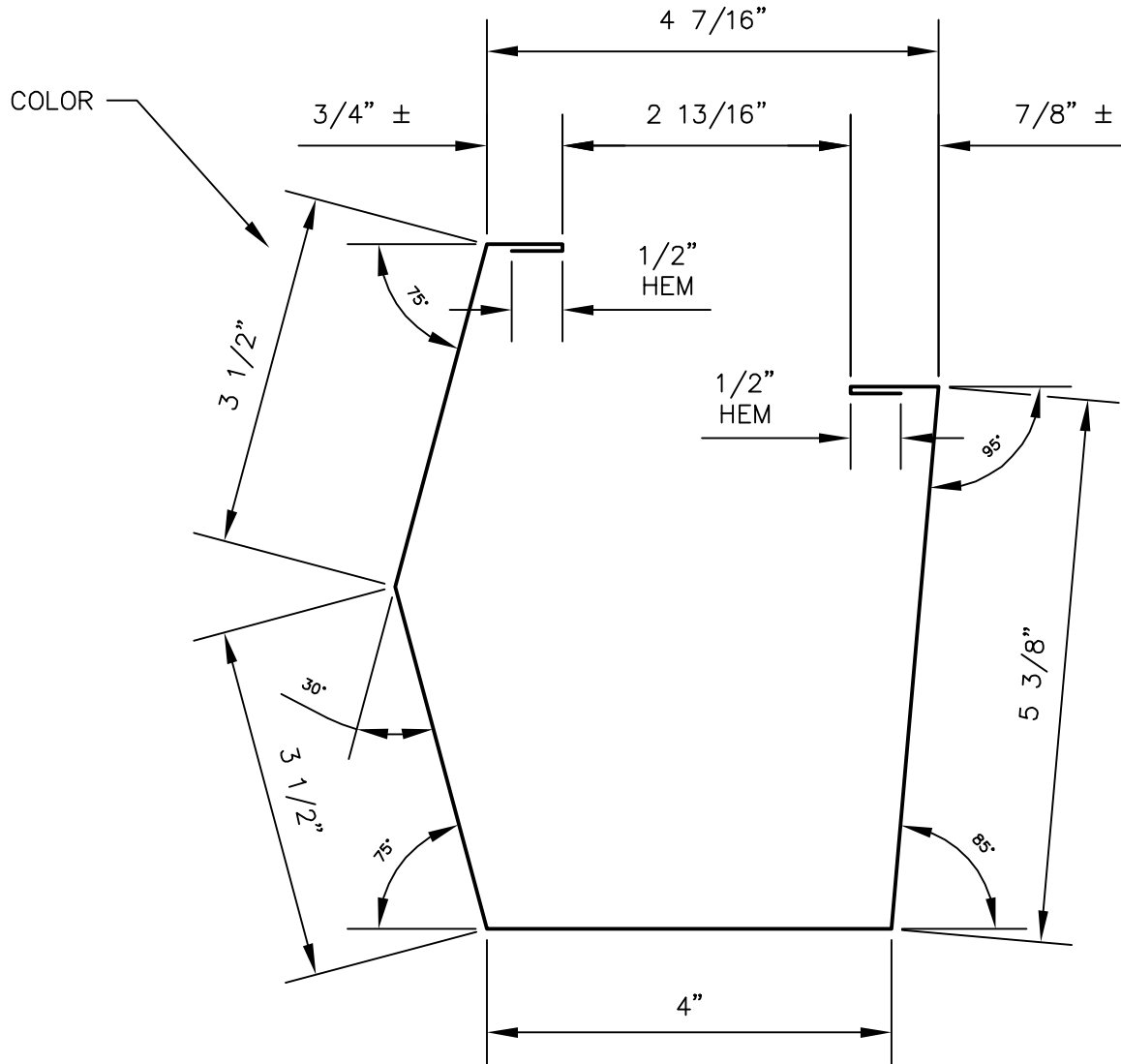

STANDARD GUTTER (1/2:12 - 2:12)

PANEL PROFILES	GAUGE
MULTI-RIB	26
R-PANEL	26

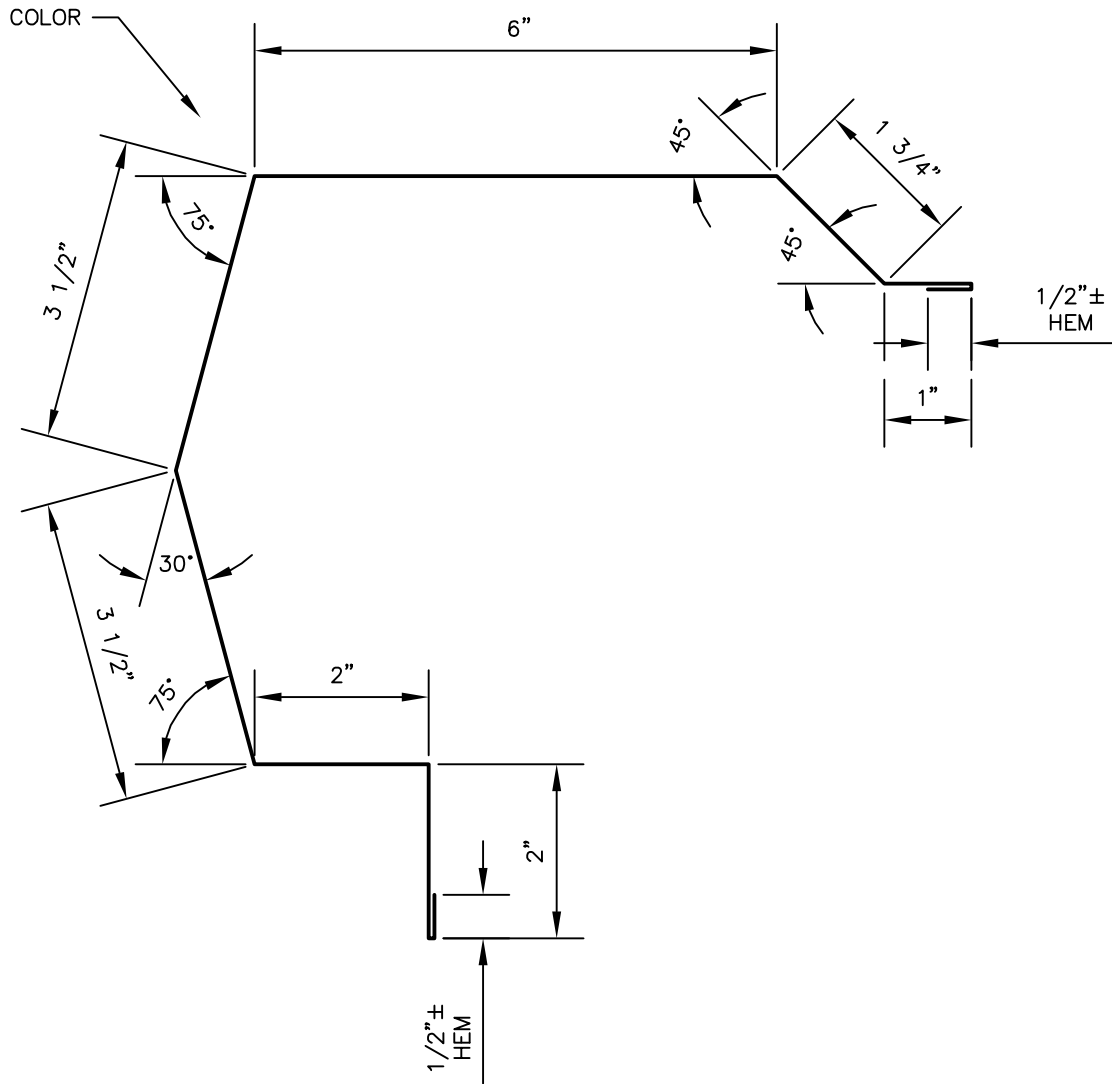

RAKE TRIM

PANEL PROFILES	GAUGE
MULTI-RIB	26
R-PANEL	26

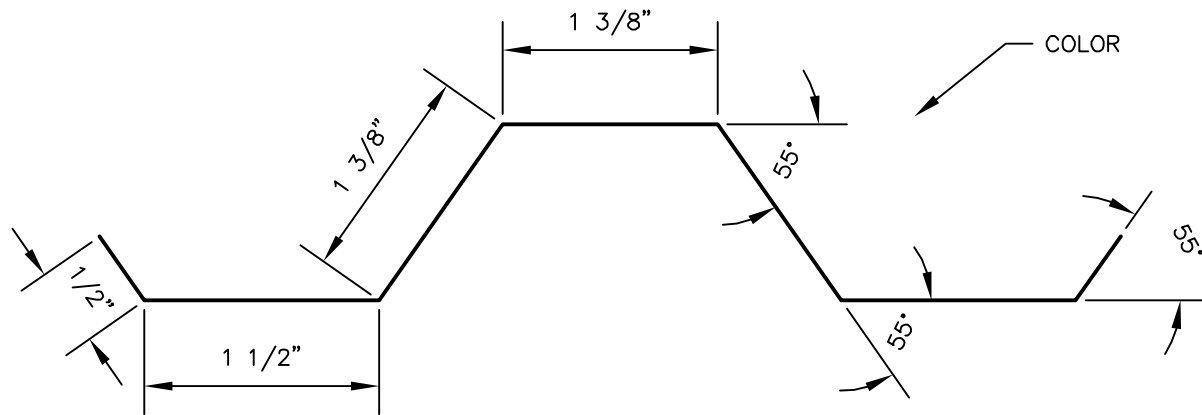

SKYLIGHT SIDE TRIM - UL90

(FOR USE WITH MULTI-RIB PANEL)

PANEL PROFILES	GAUGE
MULTI-RIB	26

11-21-14 rev.
 6-17-13 rev.
 10-12-03 rev.
 9-03-96

GIRTH: 8 1/8"
 BENDS: AS SPECIFIED

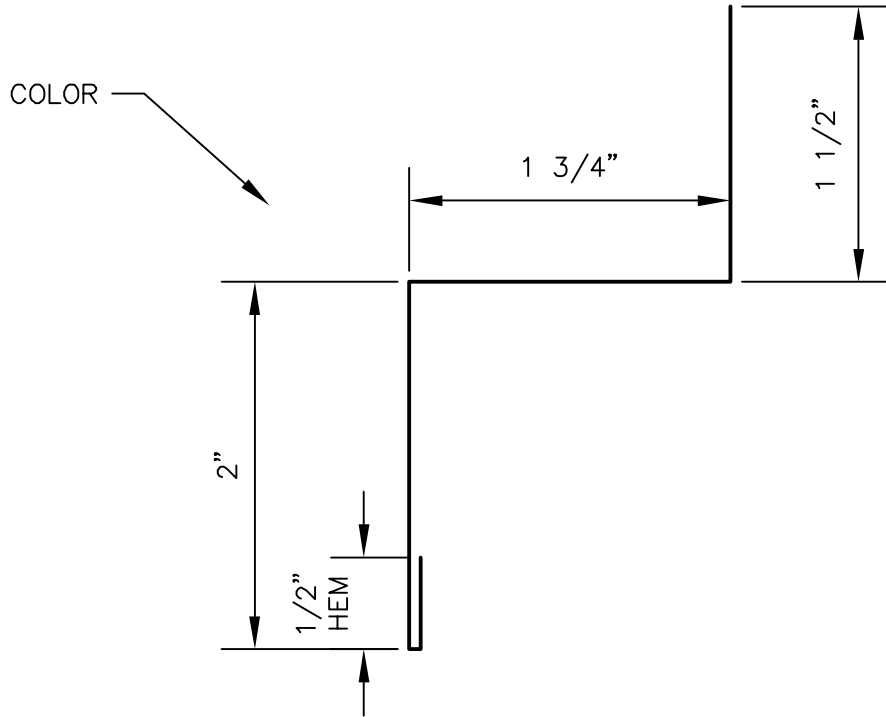

ZEE TRIM

PANEL PROFILES	GAUGE
MULTI-RIB	26
MULTI-V	26
R-PANEL	26

6-17-13 rev.
10-24-11 rev.
9-03-08

GIRTH: 5 3/4"
BENDS: AS SPECIFIED

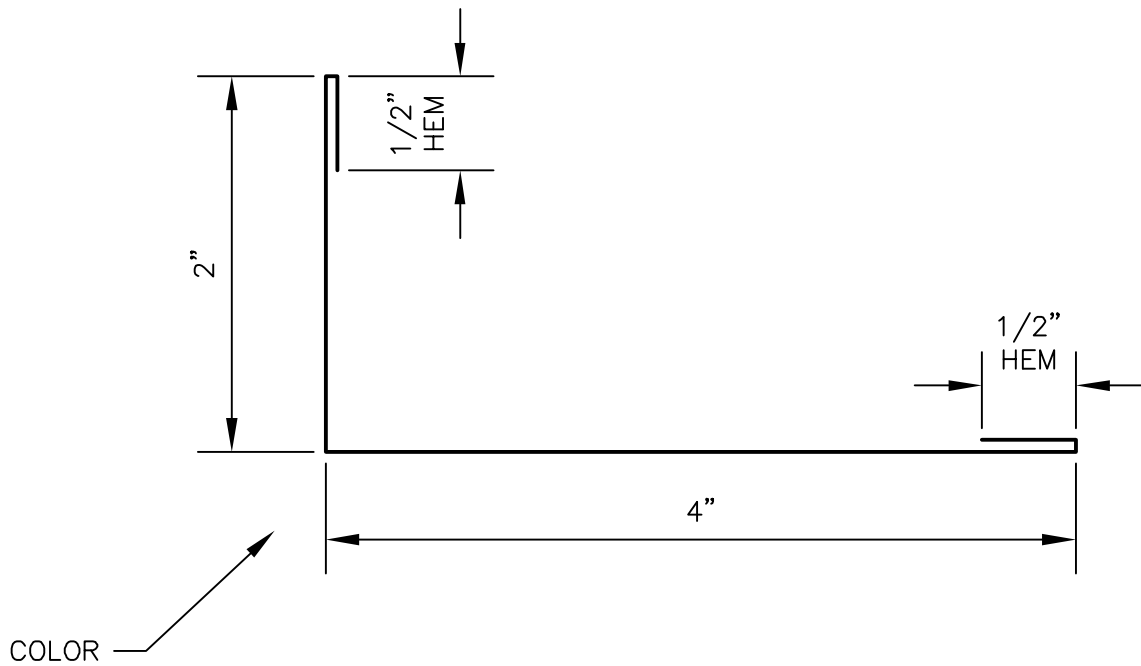

MINI JAMB/HEADER COVER

PANEL PROFILES	GAUGE
MULTI-RIB	26
MULTI-V	26
R-PANEL	26
U-PANEL	26
MEGA-RIB	26

6-17-13 rev.
10-24-11 rev.
12-22-04

GIRTH: 7"
BENDS: 90°

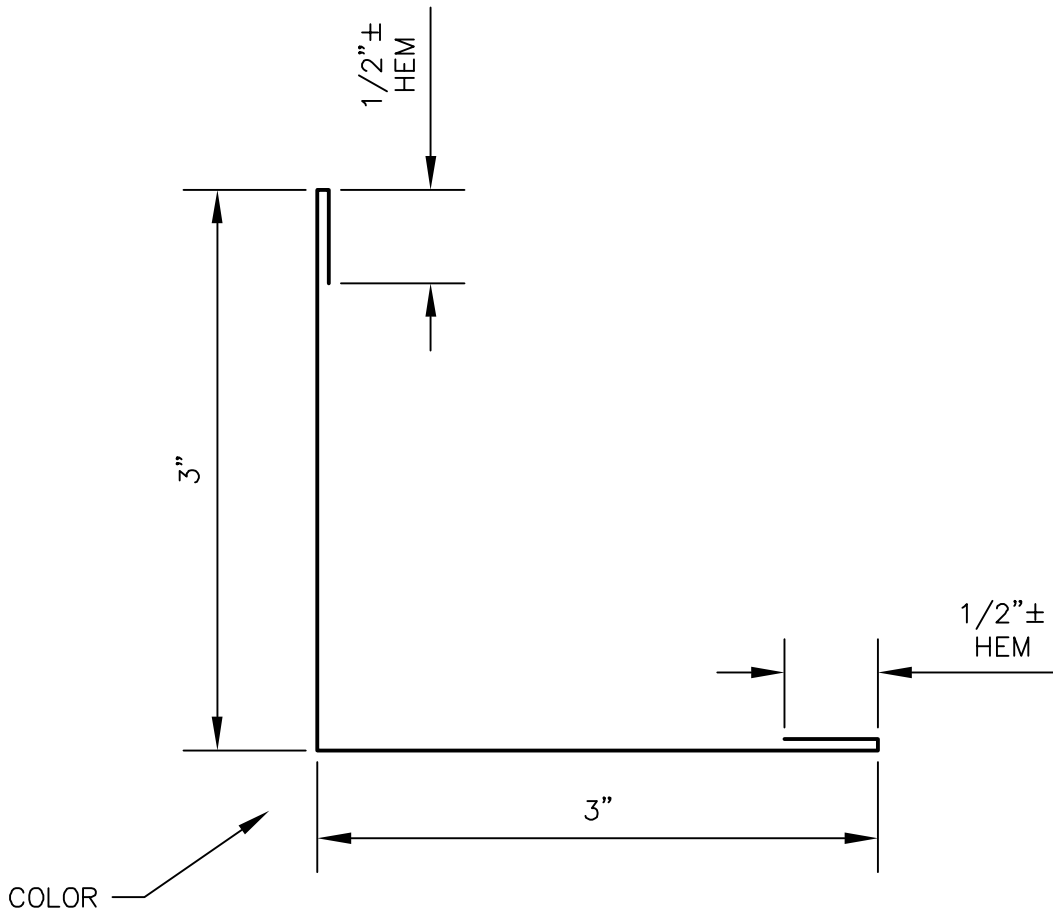

OUTSIDE ANGLE TRIM

PANEL PROFILES	GAUGE
MULTI-COR	26
M-COR	26
U-PANEL	26
MULTI-RIB	26
R-PANEL	26
MINI-RIB	26
MULTI-V	26
MATRIX	26
MEGA-RIB	24 or 26

6-25-14 rev.
 10-11-11 rev.
 9-03-96

GIRTH: 7"
 BENDS: 90°

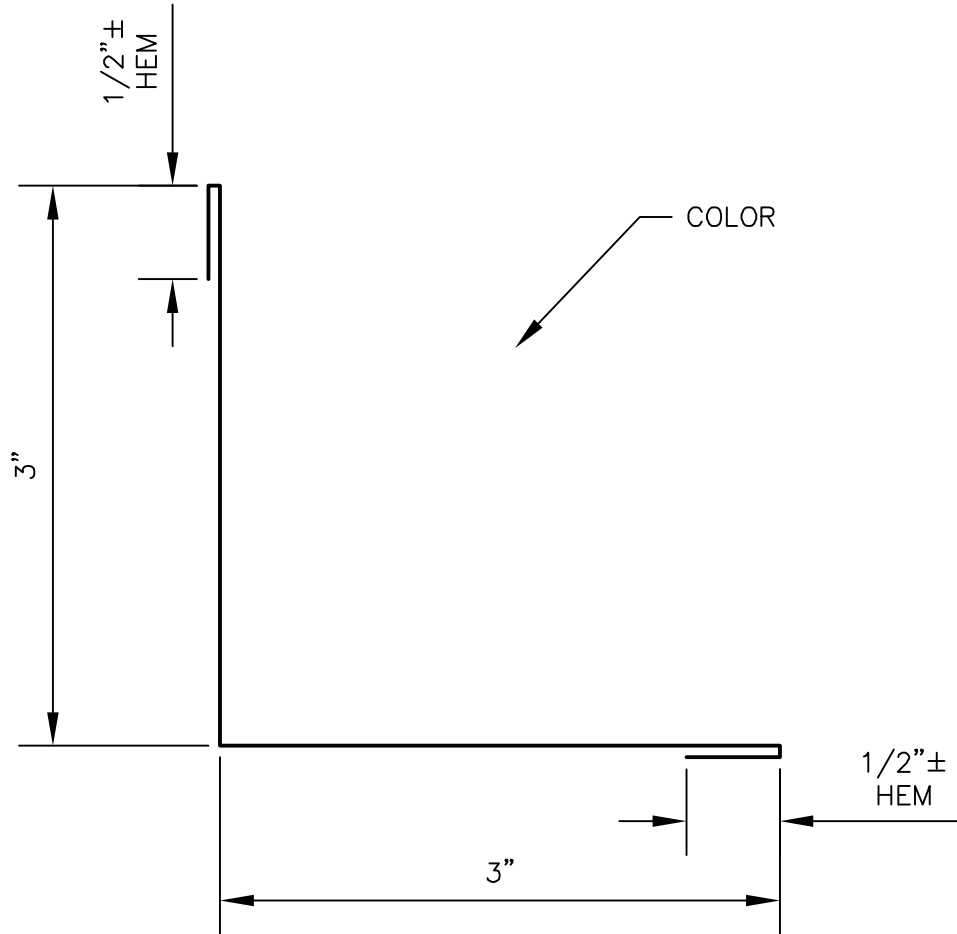

INSIDE ANGLE TRIM

PANEL PROFILES	GAUGE
MULTI-RIB	26
R-PANEL	26
U-PANEL	26
MINI-RIB	26
MULTI-V	26
MATRIX	26

6-03-14 rev.
 10-13-11 rev.
 9-03-96

GIRTH: 7"
 BENDS: 90° AND AS SPECIFIED

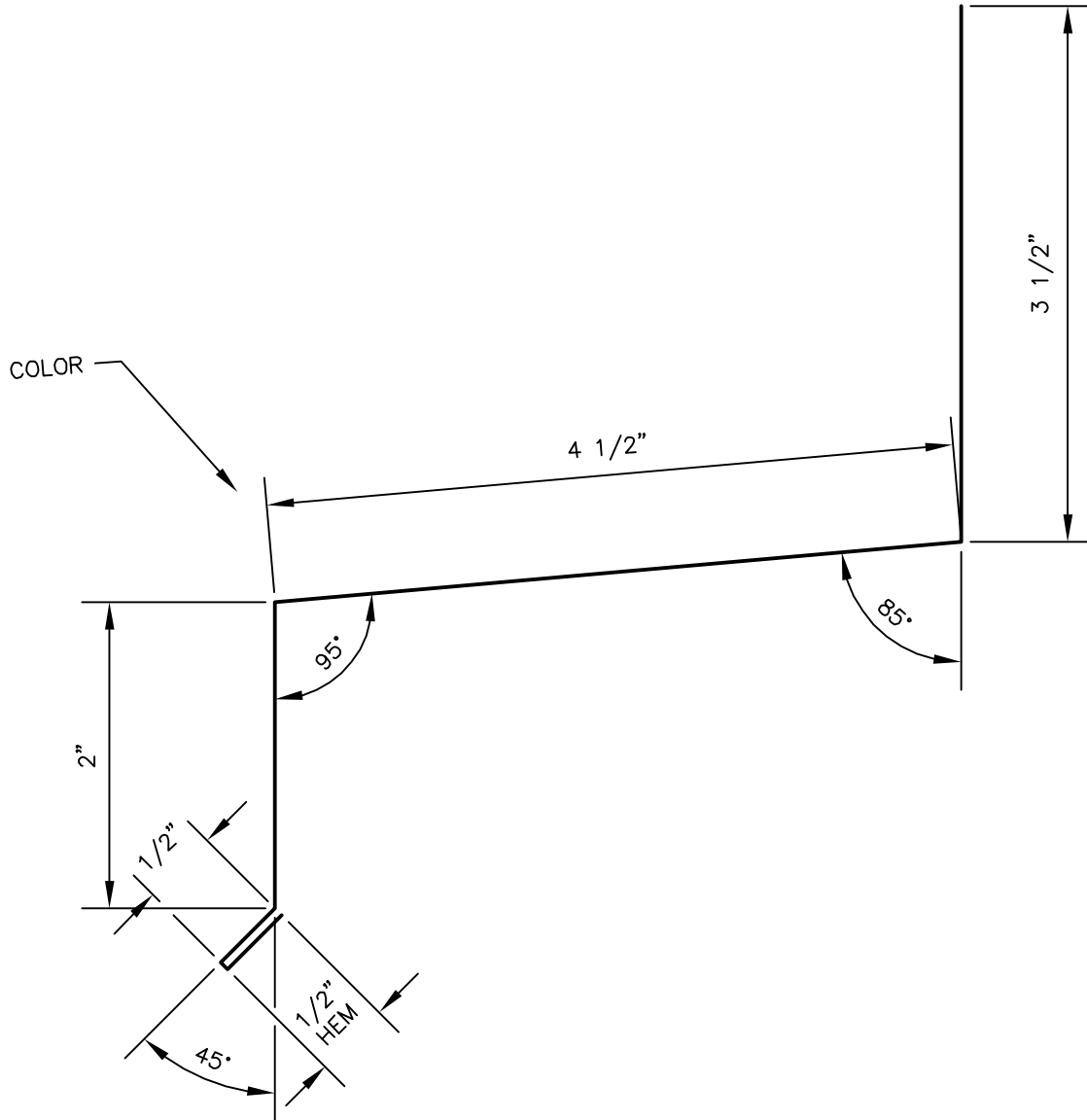

MASONRY WAINSCOAT TRIM

PANEL PROFILES	GAUGE
MULTI-RIB	26
MULTI-V	26
R-PANEL	26
U-PANEL	26
MEGA-RIB	26
M-COR	26
MULTI-COR	26

8-26-13 rev.
 10-24-11 rev.
 9-03-96

GIRTH: 11"
 BENDS: 90° AND AS SPECIFIED

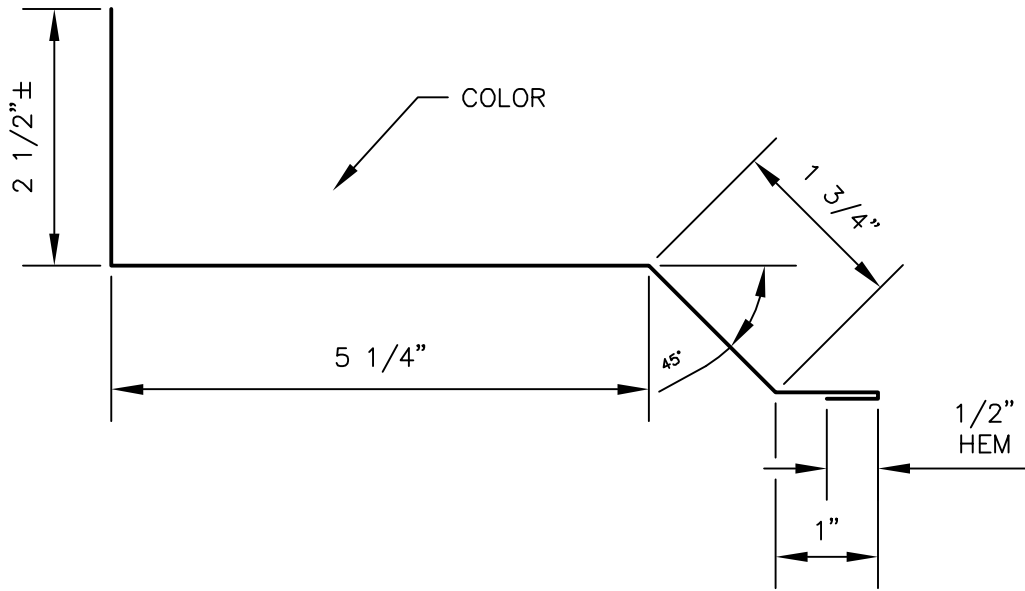

RAKE TIE-IN TRIM (ENDWALL)

PANEL PROFILES	GAUGE
MULTI-RIB	26
R-PANEL	26

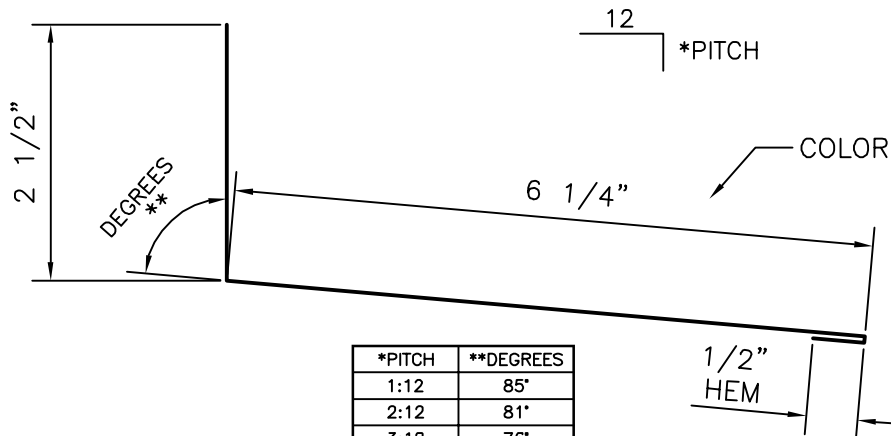

*PITCH	**DEGREES
1:12	85°
2:12	81°
3:12	76°
4:12	72°
5:12	67°
6:12	63°
7:12	60°
8:12	56°
9:12	53°
10:12	50°
11:12	47°
12:12	45°

HIGH SIDE TIE-IN TRIM (HEADWALL)

PANEL PROFILES	GAUGE
MULTI-RIB	26
R-PANEL	26
U-PANEL	26
MULTI-COR	26
M-COR	26
MEGA-RIB	24 or 26

5-28-14 rev.
 8-21-13 rev.
 4-29-11

GIRTH: 9 1/4"
 BENDS: AS SPECIFIED

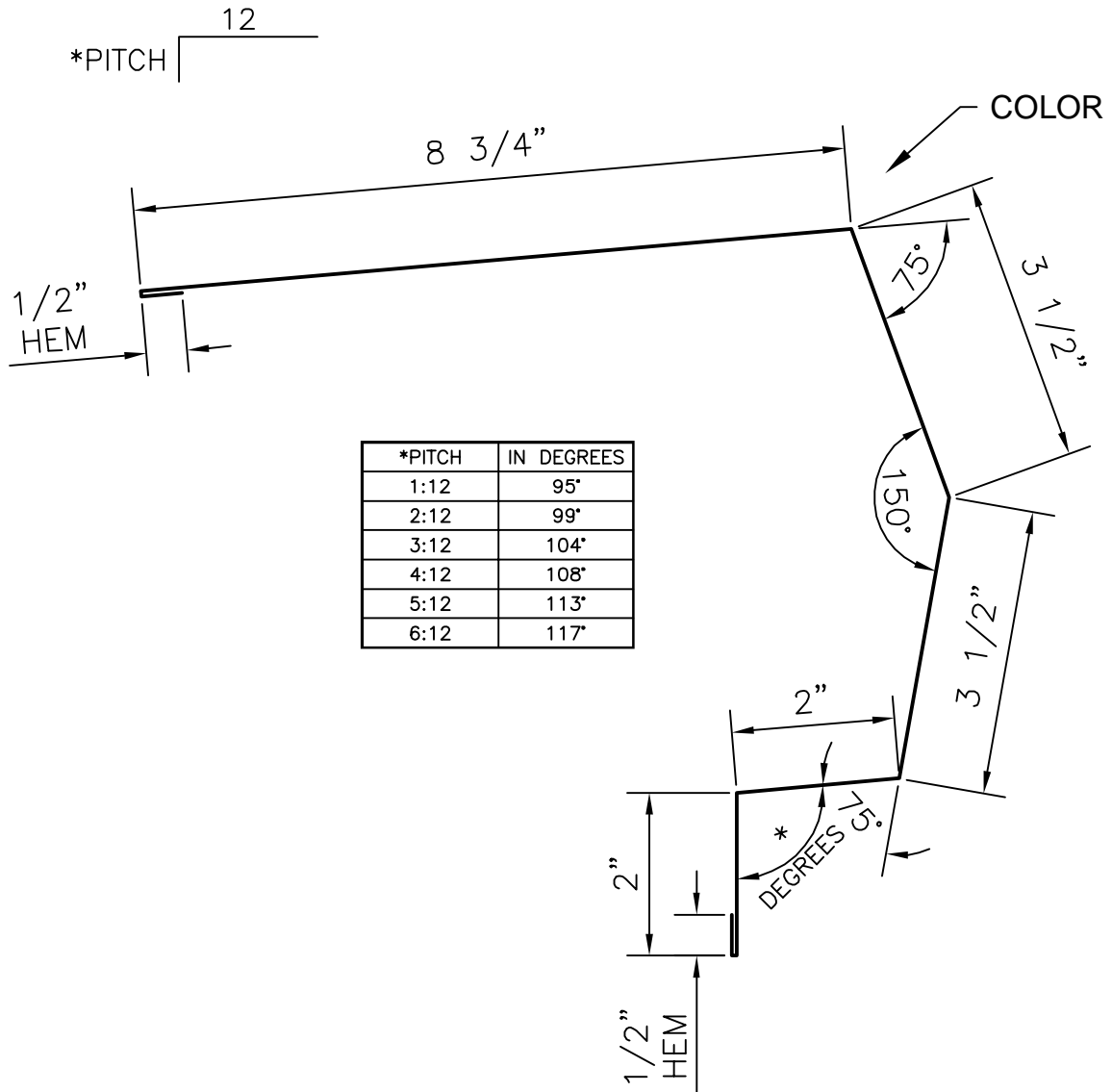

HIGH SIDE EAVE TRIM

PANEL PROFILES	GAUGE
MULTI-RIB	26
R-PANEL	26
U-PANEL	26
MEGA-RIB	24 or 26

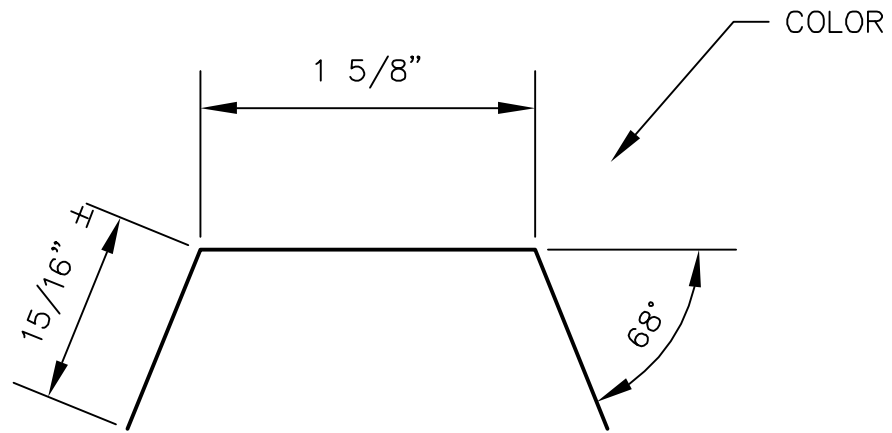

GUTTER STRAP

PANEL PROFILES	GAUGE
MULTI-RIB	26
R-PANEL	26

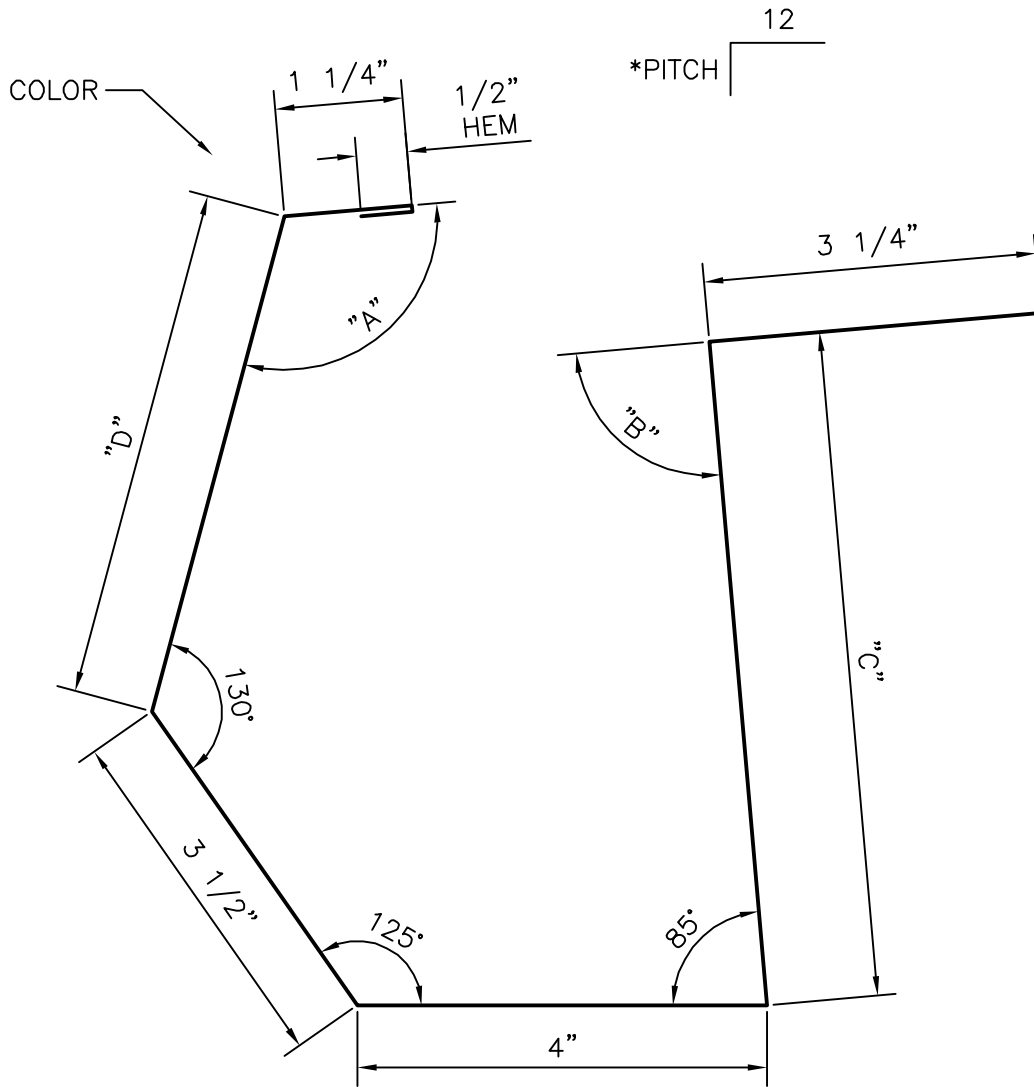

SCULPTURED GUTTER

PANEL PROFILES	GAUGE
MULTI-RIB	26
R-PANEL	26

TABLE				
*PITCH	"A"	"B"	"C"	"D"
1:12	110°	90°	6 1/2"	5"
2:12	114°	86°	6 13/16"	4 11/16"
3:12	119°	81°	7"	4 1/2"
4:12	123°	77°	7 3/16"	4 5/16"
5:12	127°	73°	7 3/8"	4 1/8"

6-17-13 rev.
 1-03-11 rev.
 9-23-11

GIRTH: 24"
 BENDS: 90° AND AS SPECIFIED



*PITCH $\frac{12}{\quad}$

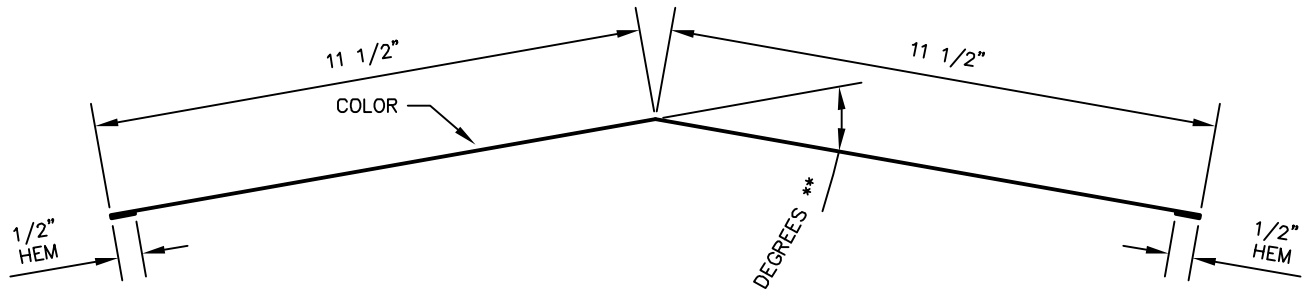

*PITCH	**DEGREES
1:12	10°
2:12	19°
3:12	28°
4:12	37°
5:12	45°
6:12	53°

PANEL PROFILES	GAUGE
U-PANEL	26
MIRAGE	26
MIRAGE II	26
MULTI-RIB	26
R-PANEL	26
MEGA-RIB	24 or 26
M-COR	26
MULTI-COR	26
MASTERLOK-90	24
MASTERLOK-FS	24
MAXIMA 1.5"	24
MAXIMA 2"	24
MAXIMA 3"	24
MAXIMA ADV	24

RIDGE CAP TRIM

5-28-14 rev.
7-19-11 rev.
2-20-04

GIRTH: 24"
BENDS: 90° AND AS SPECIFIED

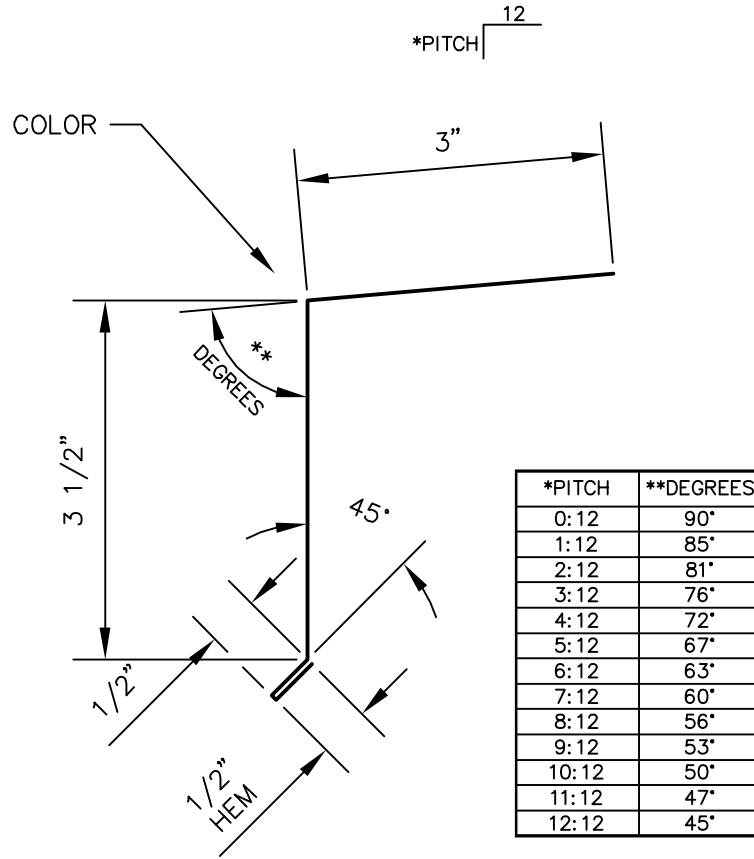

EAVE TRIM

PANEL PROFILES	GAUGE
MULTI-RIB	26
R-PANEL	26
MULTI-COR	26
M-COR	26
U-PANEL	26
MAX-RIB	26
MESA	26

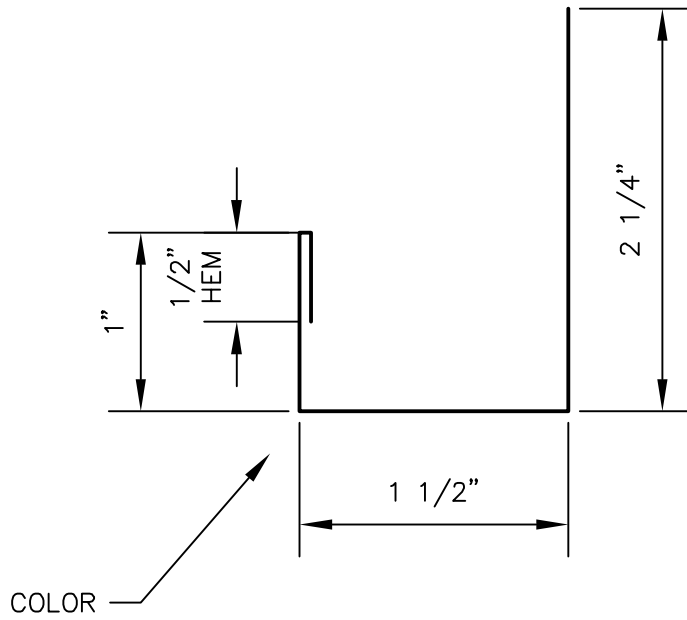

HEAD TRIM

PANEL PROFILES	GAUGE
MULTI-RIB	26
MULTI-V	26
R-PANEL	26

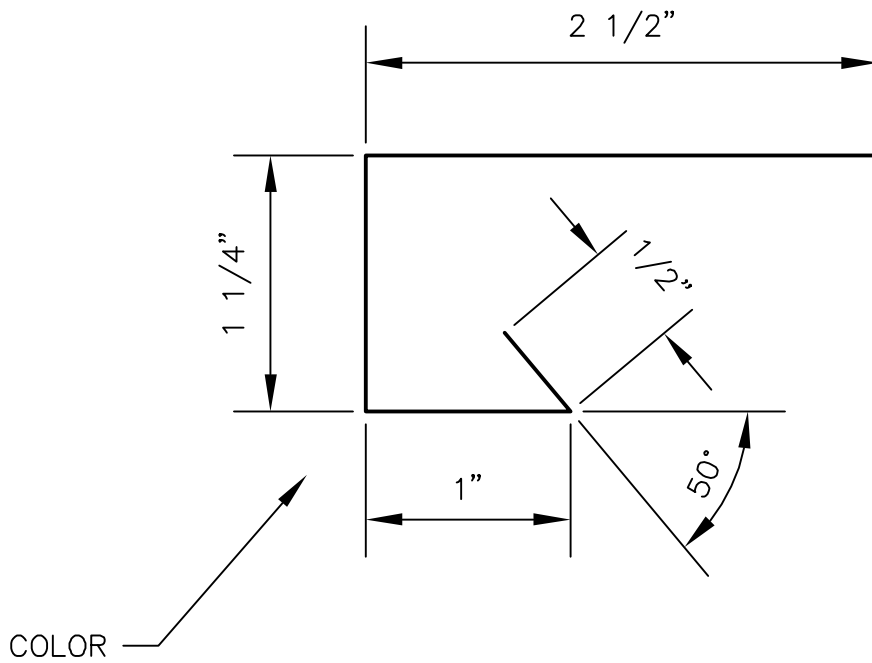

JAMB TRIM

PANEL PROFILES	GAUGE
MULTI-RIB	26
MULTI-V	26
R-PANEL	26

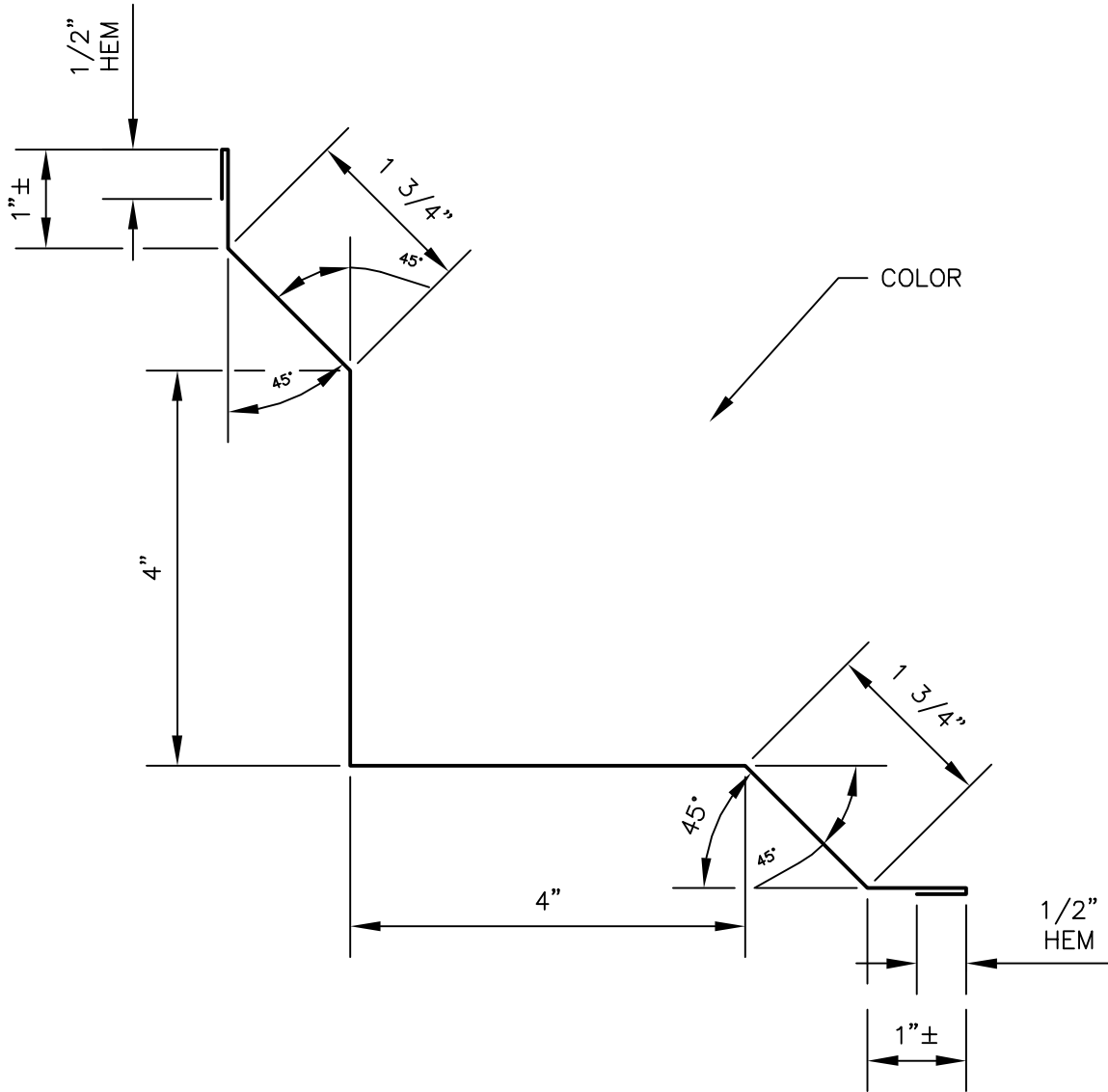

INSIDE CORNER TRIM

PANEL PROFILES	GAUGE
MULTI-RIB	26
R-PANEL	26

6-17-13 rev.
 10-13-11 rev.
 9-03-96

GIRTH: 14 1/2"
 BENDS: 90° AND AS SPECIFIED

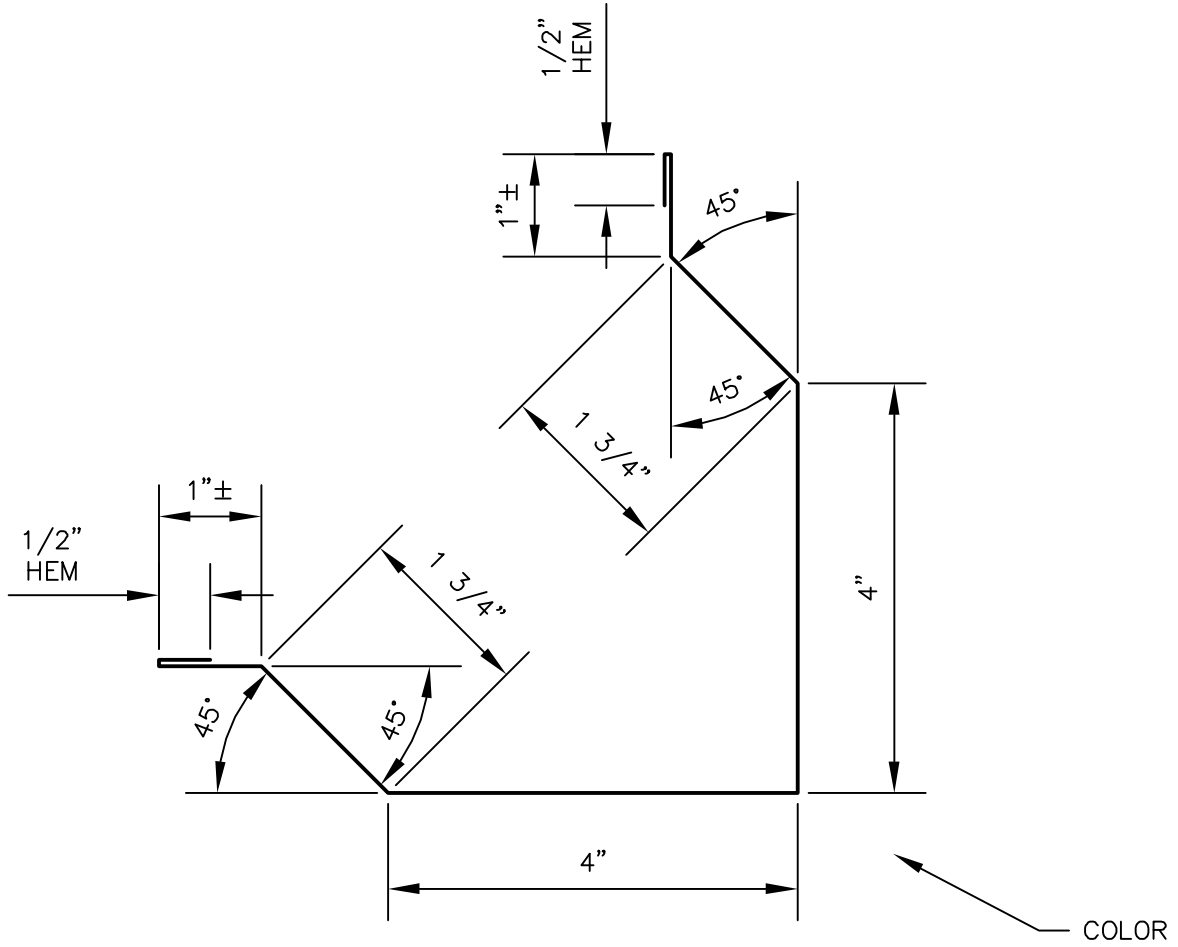

OUTSIDE CORNER TRIM

PANEL PROFILES	GAUGE
MULTI-RIB	26
R-PANEL	26

6-17-13 rev.
10-13-11 rev.
9-03-96

GIRTH: 14 1/2"
BENDS: 90° AND AS SPECIFIED

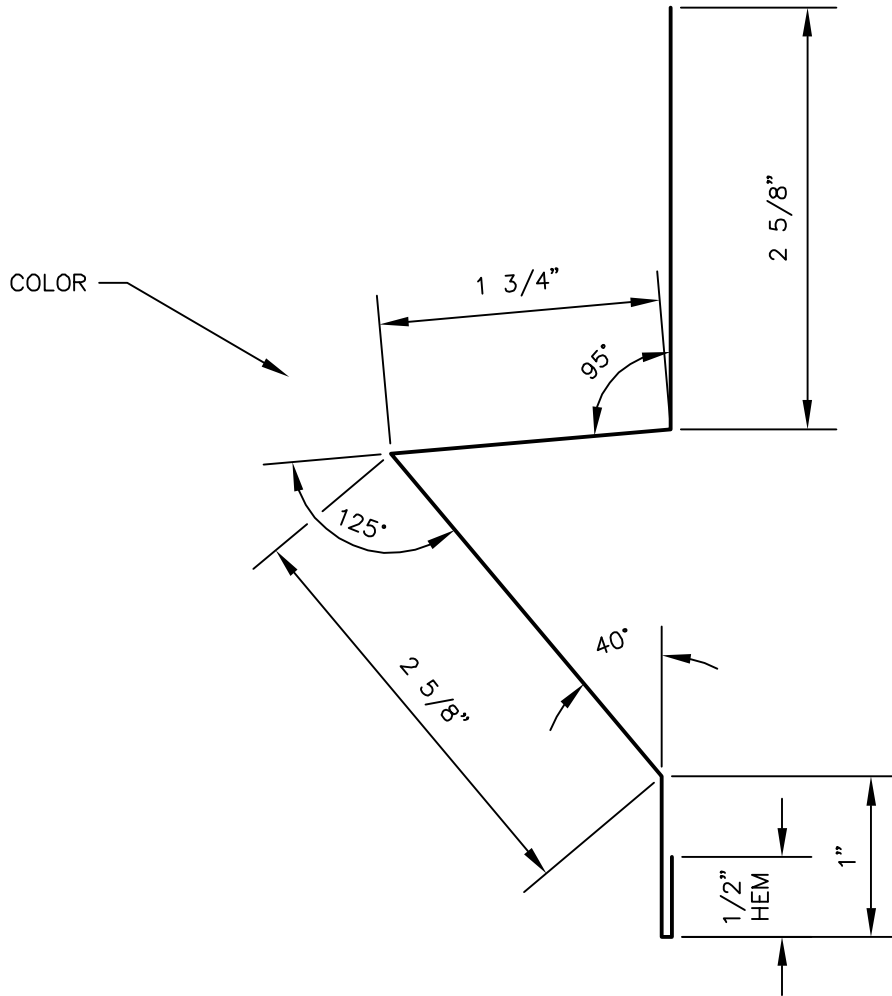

BASE TRIM

PANEL PROFILES	GAUGE
MULTI-RIB	26
MULTI-V	26
R-PANEL	26

6-17-13 rev.
 10-24-11 rev.
 9-03-96

GIRTH: 8 1/2"
 BENDS: 90° AND AS SPECIFIED

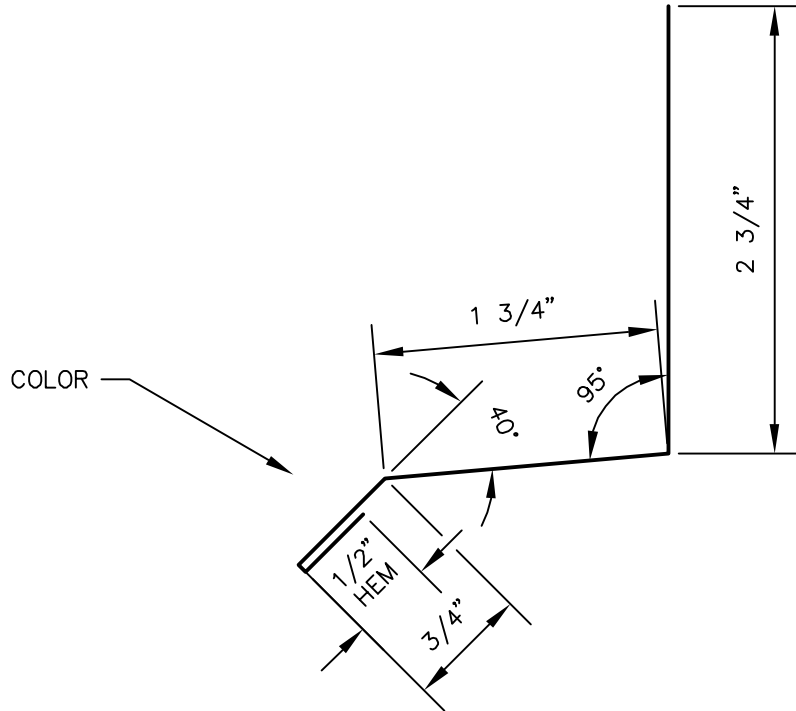

SIMPLE BASE TRIM

PANEL PROFILES	GAUGE
MULTI-RIB	26
MULTI-V	26
R-PANEL	26
MEGA-RIB	26

6-17-13 rev.
 10-24-11 rev.
 9-03-96

GIRTH: 5 3/4"
 BENDS: 90° AND AS SPECIFIED

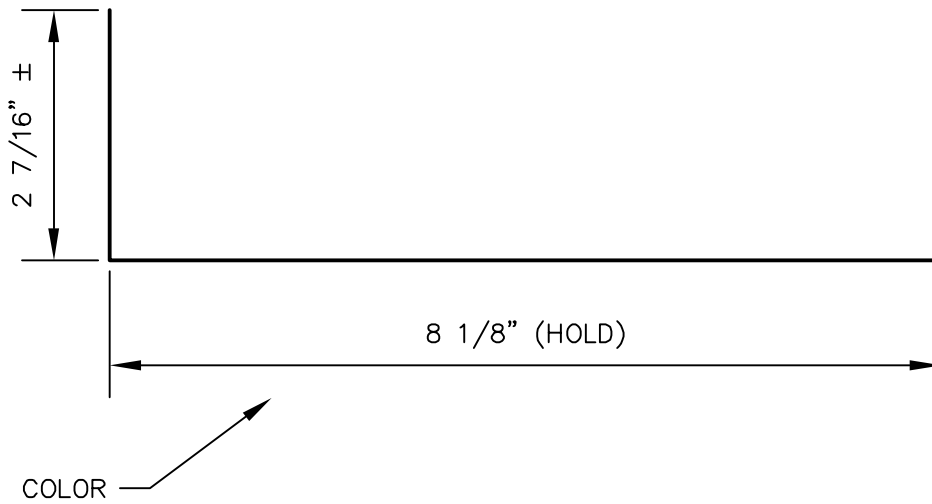

JAMB / HEAD COVER TRIM

PANEL PROFILES	GAUGE
MULTI-RIB	26
MULTI-V	26
R-PANEL	26
U-PANEL	26
MEGA-RIB	26
MULTI-COR	26
M-COR	26

6-24-14 rev.
10-24-11 rev.
9-04-96

GIRTH: 13"
BENDS: 90°

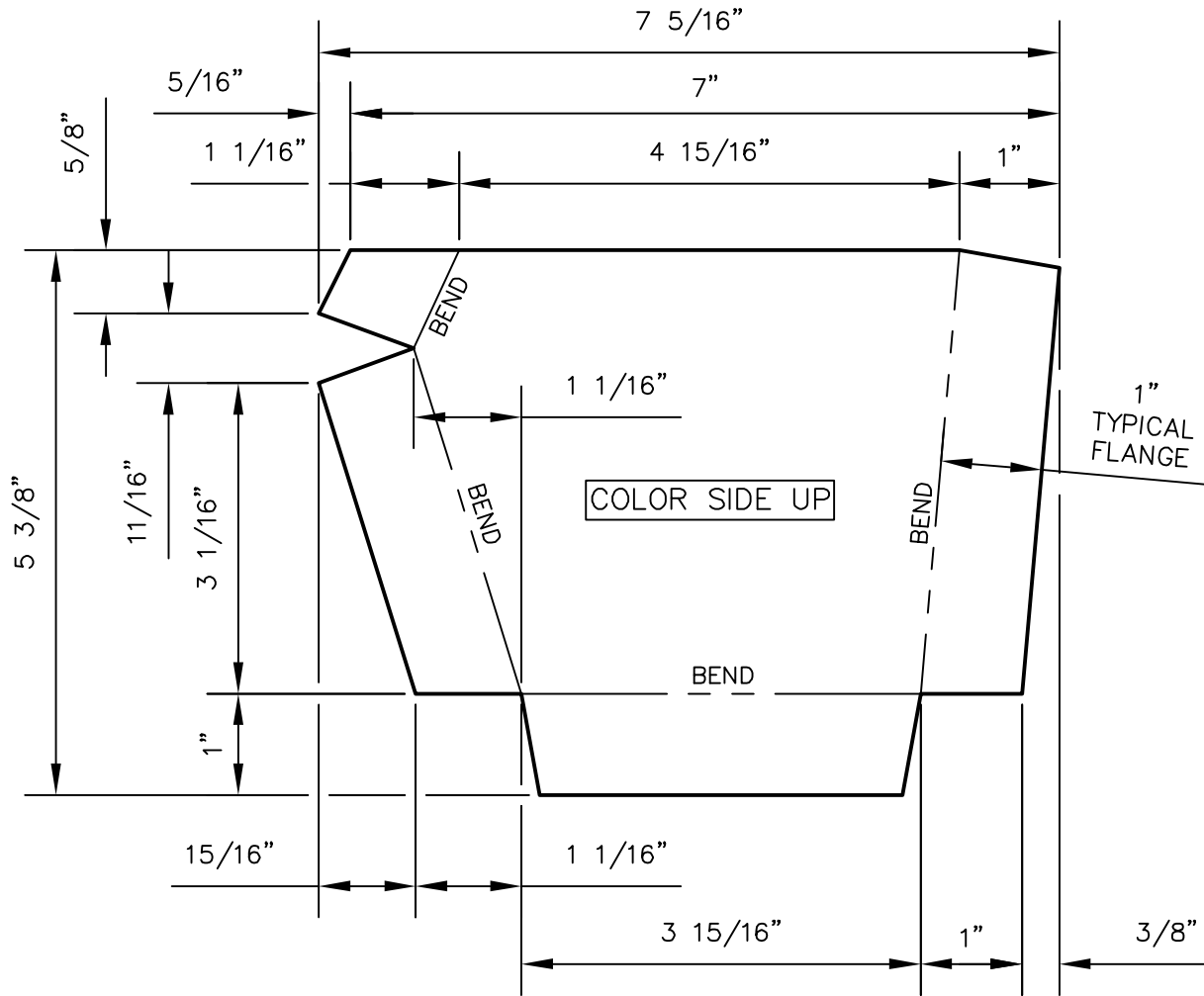

GUTTER END CAP - PATTERN

(1/2:12 TO 2:12 PITCH)

PANEL PROFILES	GAUGE
MULTI-RIB	24 or 26
R-PANEL	24 or 26
MEGA-RIB	26

5-28-14 rev.
 9-23-07 rev.
 2-20-04

GIRTH: 5 3/8" X 7 5/16"
 BENDS: DOWN 90°
 SEE DWG ITW-0125 FOR FINISHED DETAIL

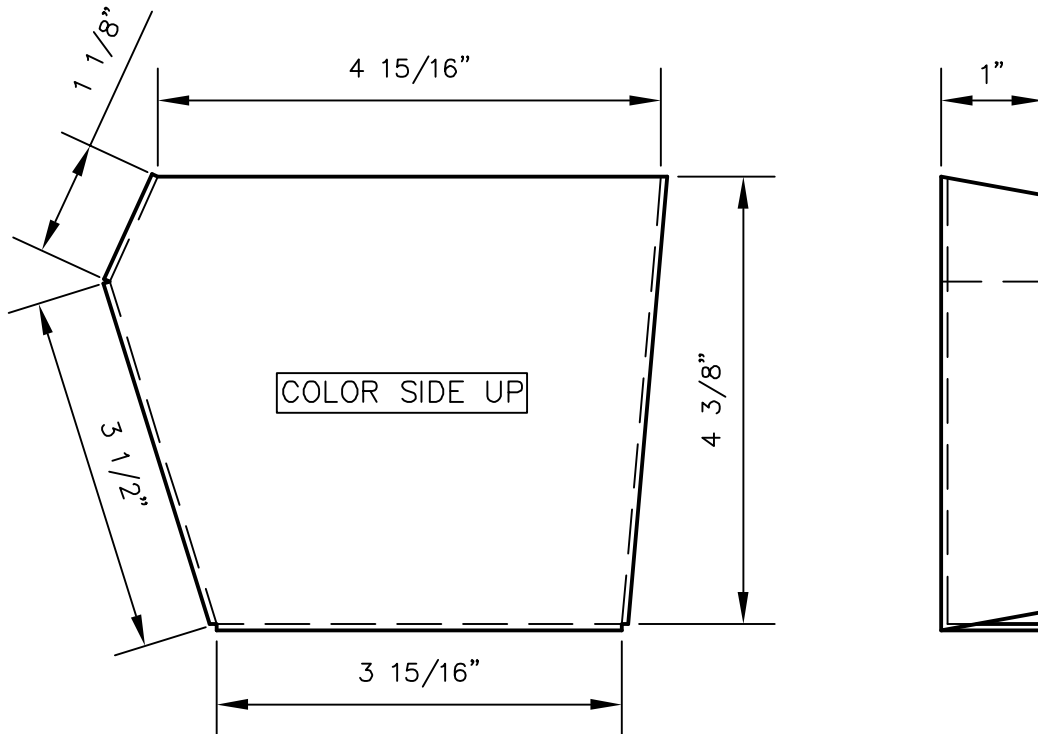

GUTTER END CAP - FINISHED

(1/2:12 TO 2:12 PITCH)

PANEL PROFILES	GAUGE
MULTI-RIB	24 or 26
R-PANEL	24 or 26
MEGA-RIB	26

5-28-14 rev.
9-23-07 rev.
2-20-04

GIRTH: SEE DWG ITW-0124
BENDS: SEE DWG ITW-0124

112A

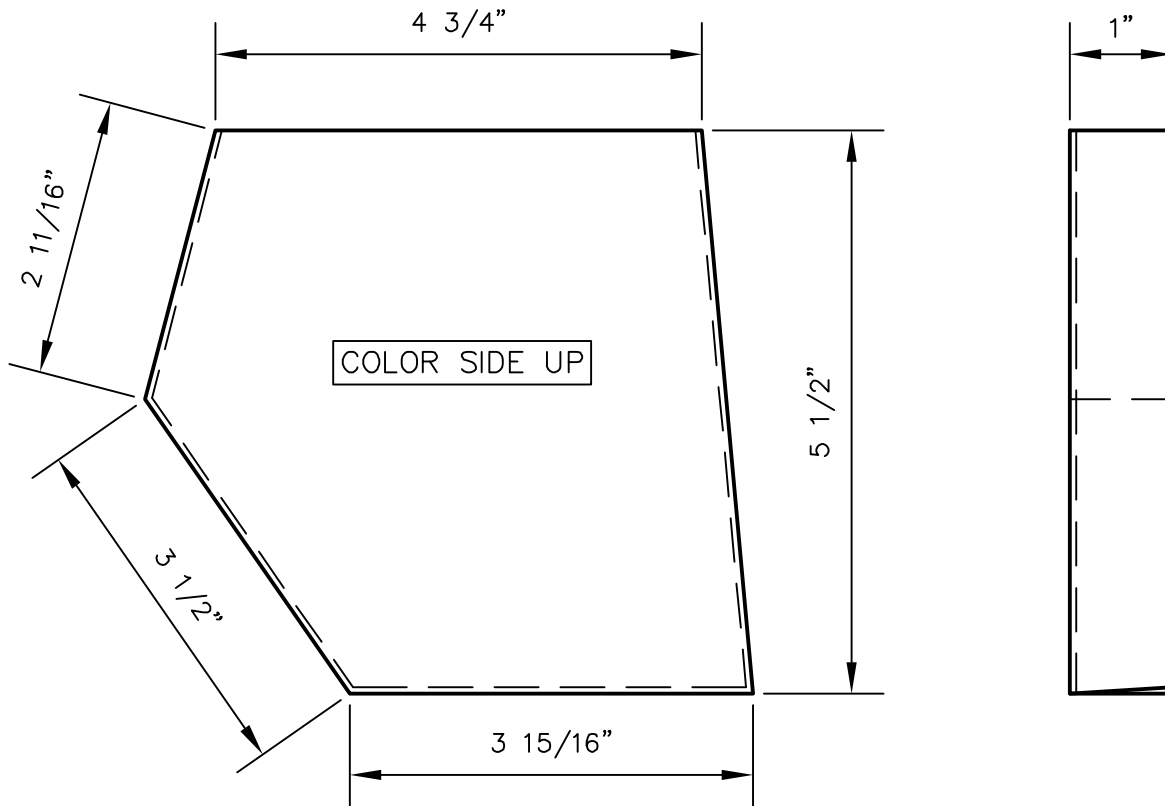

GUTTER END CAP - SCULPTURED

(RIGHT HAND SHOWN - LEFT HAND OPP.)

PANEL PROFILES	GAUGE
MULTI-RIB	24 or 26
R-PANEL	24 or 26

8-22-13 rev.
9-23-07 rev.
9-16-96

GIRTH: SEE PATTERN ITW-0131
BENDS: SEE PATTERN ITW-0131

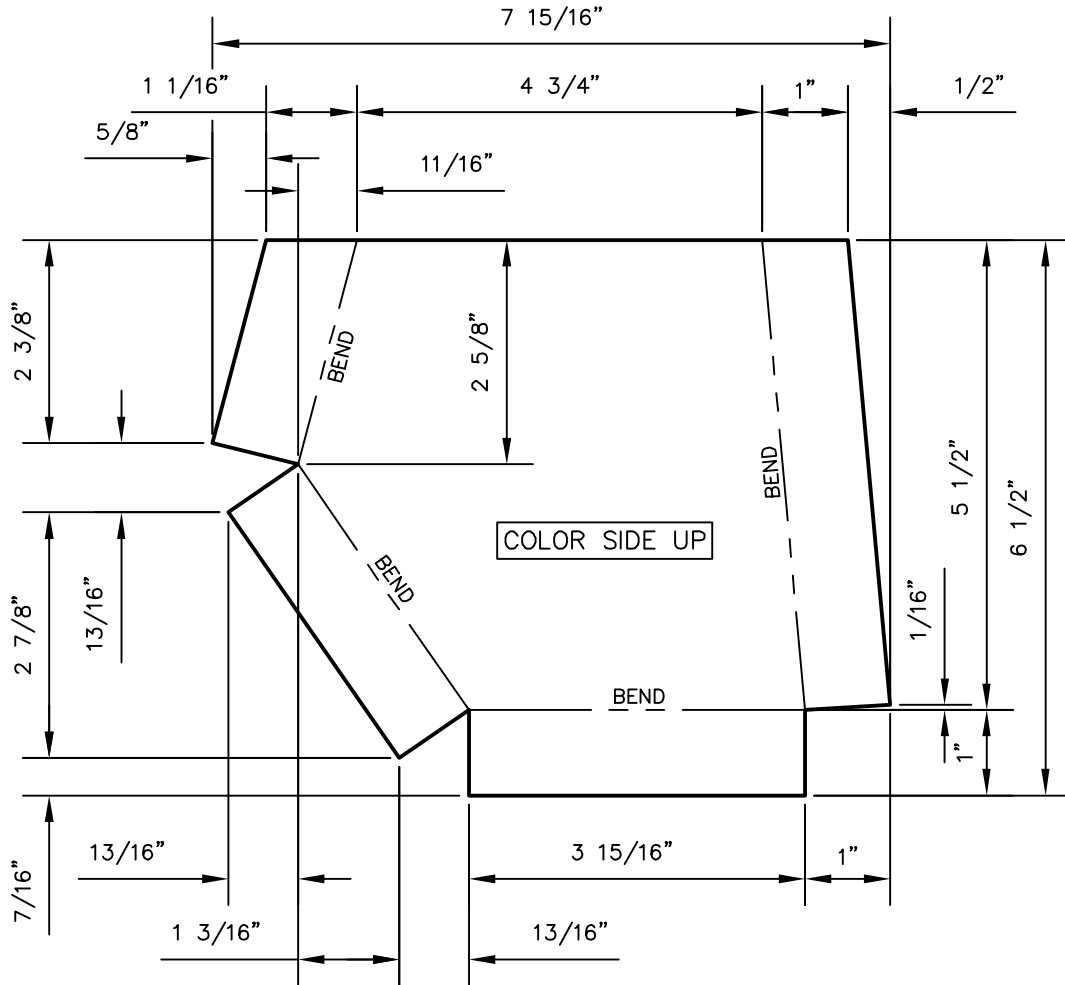

GUTTER END CAP - SCULPTURED

RIGHT HAND SHOWN - LEFT HAND OPP.)

PANEL PROFILES	GAUGE
MULTI-RIB	24 or 26
R-PANEL	24 or 26

8-22-13 rev.
 9-23-07 rev.
 9-16-96

GIRTH: $6 \frac{1}{2}$ " X $7 \frac{15}{16}$ "
 BENDS: DOWN 90°

172A

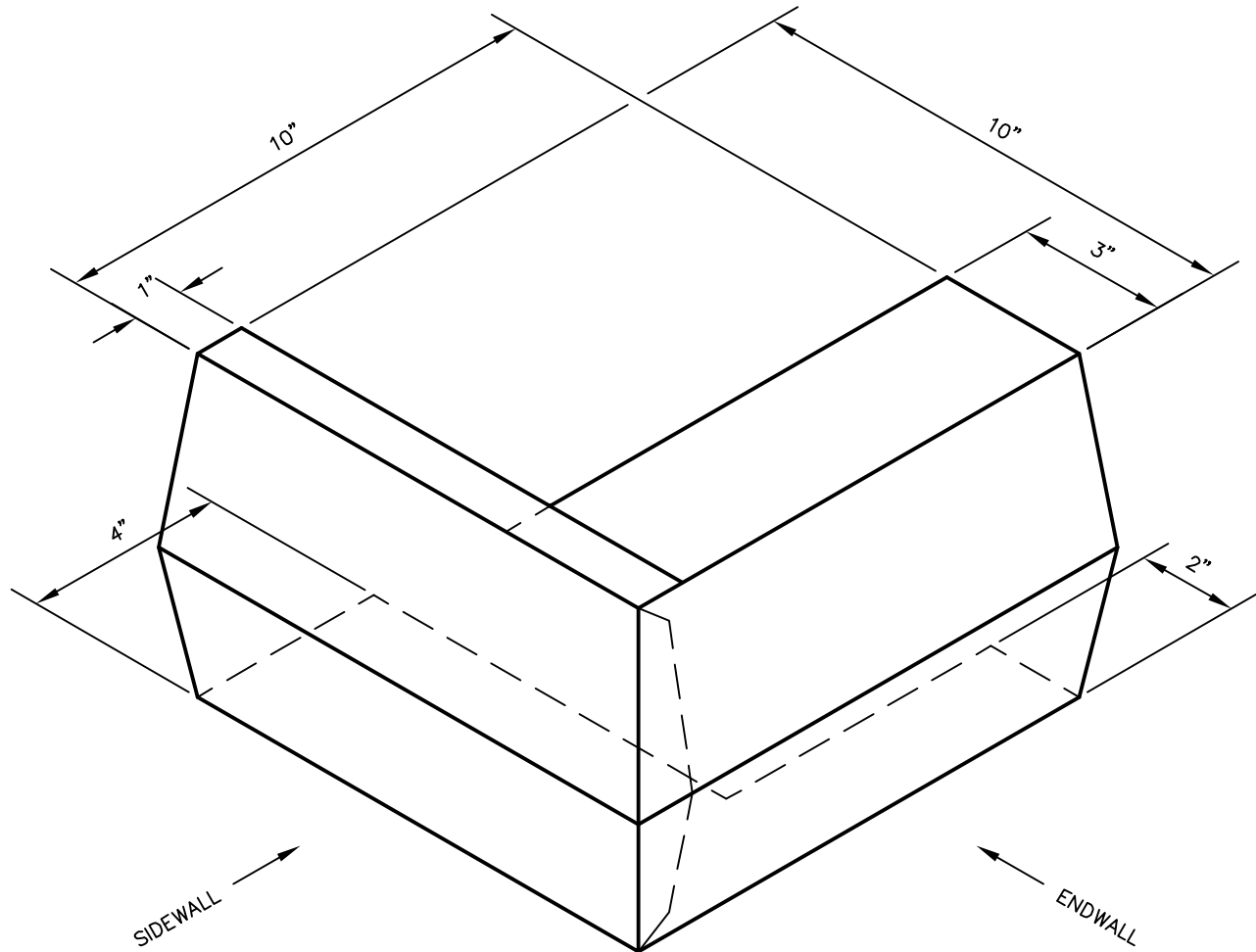

OUTSIDE CORNER BOX

(RIGHT HAND SHOWN)
(LEFT HAND OPP.)
(1/2:12 - 2:12 PITCHES)

PANEL PROFILES	GAUGE
MULTI-RIB	26
R-PANEL	26
U-PANEL	26
MIRAGE	24 or 26
MIRAGE II	24 or 26
MEGA-RIB	26

5-28-14 rev.
7-26-11 rev.
9-04-96

GIRTH: SEE PATTERN ITW-0137 & ITW-0138
BENDS: SEE PATTERN ITW-0137 & ITW-0138

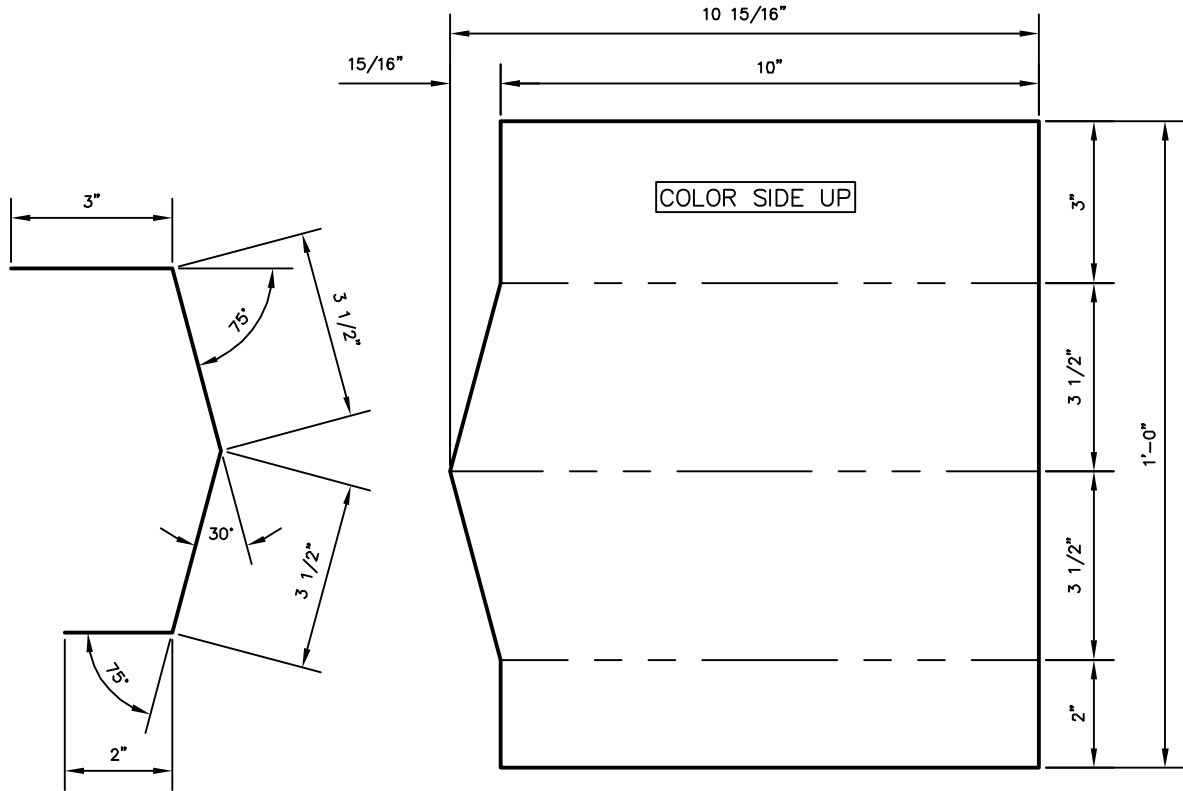

GUTTER CORNER BOX - PATTERN (ENDWALL)

(ASSEMBLE 1 R.H. & 1 L.H.)
 (RIGHT HAND SHOWN - LEFT HAND OPP.)

PANEL PROFILES	GAUGE
MULTI-RIB	26
R-PANEL	26
U-PANEL	26
MIRAGE	24 or 26
MIRAGE II	24 or 26
MEGA-RIB	26

5-28-14 rev.
 7-26-11 rev.
 9-16-96

GIRTH: 10 15/16" X 1'-0"
 BENDS: AS SPECIFIED

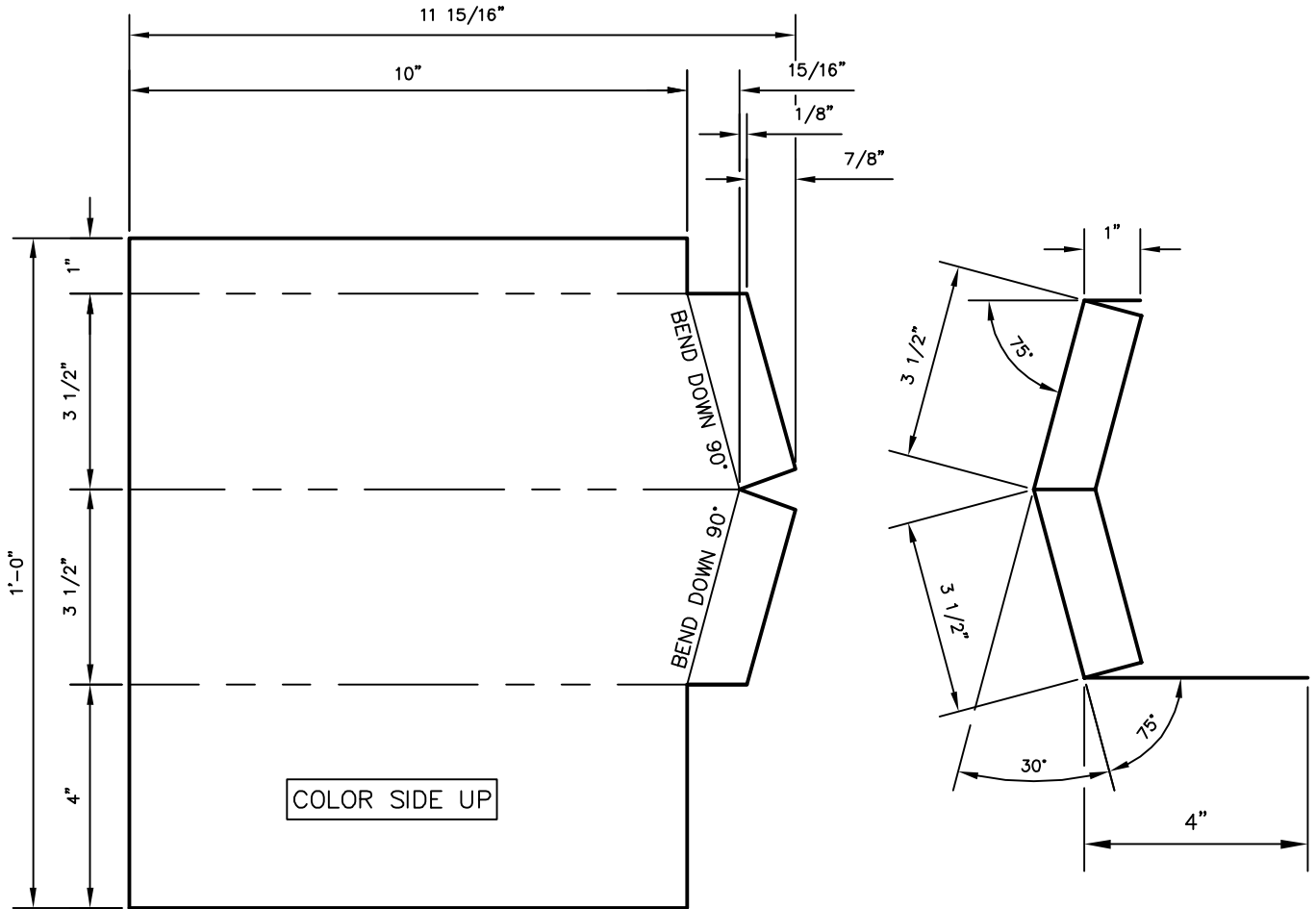

GUTTER CORNER BOX - PATTERN (SIDEWALL)

(ASSEMBLE 1 R.H. & 1 L.H.)
 (RIGHT HAND SHOWN - LEFT HAND OPP.)

PANEL PROFILES	GAUGE
MULTI-RIB	26
R-PANEL	26
U-PANEL	26
MIRAGE	24 or 26
MIRAGE II	24 or 26
MEGA-RIB	26

5-28-14 rev.
 7-26-11 rev.
 9-16-96

GIRTH: 1'-0" X 11 15/16"
 BENDS: AS SPECIFIED

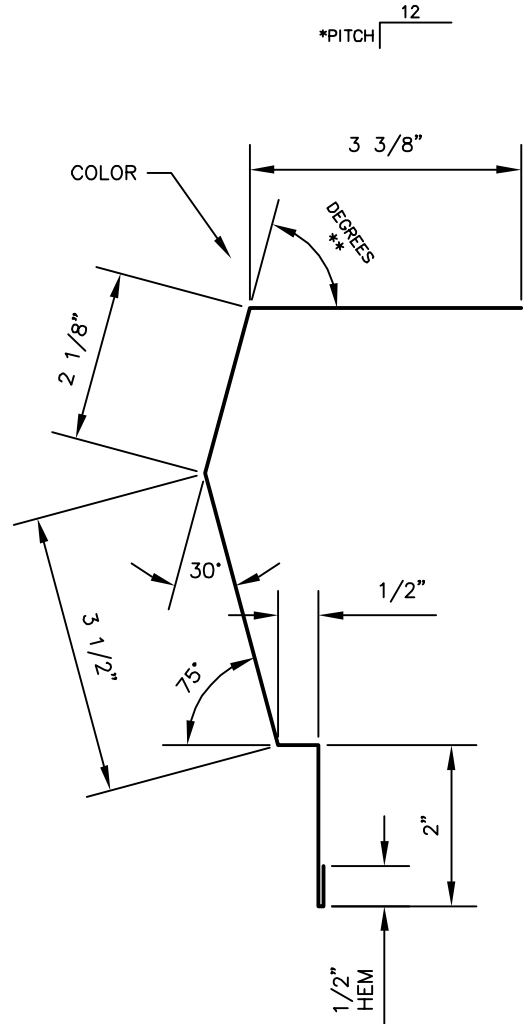

*PITCH	**DEGREES
1:12	70°
2:12	66°
3:12	61°
4:12	57°
5:12	52°
6:12	48°

SCULPTURED EAVE TRIM

PANEL PROFILES	GAUGE
MULTI-RIB	26
R-PANEL	26

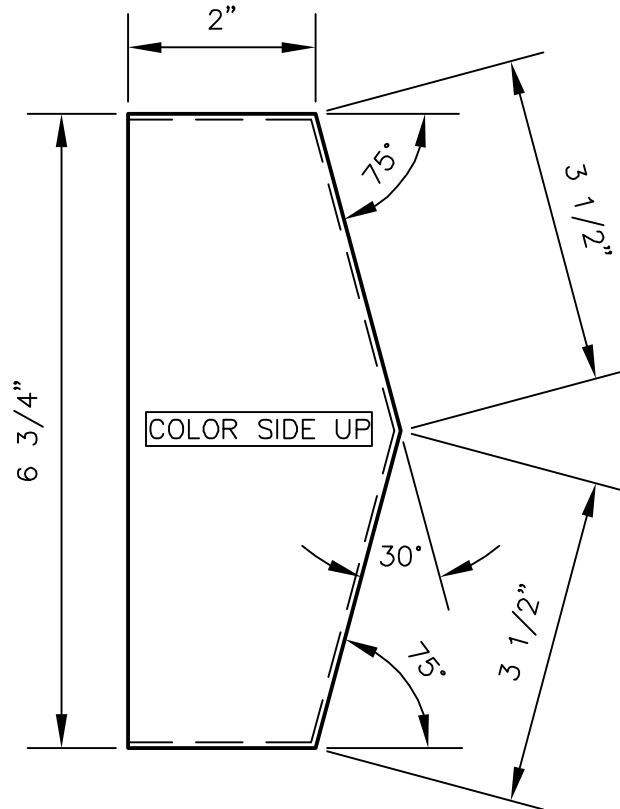

RAKE CLOSURE - FINISHED

PANEL PROFILES	GAUGE
MULTI-RIB	26
R-PANEL	26
U-PANEL	26
MIRAGE I	24 or 26
MIRAGE II	24 or 26
MEGA-RIB	26

5-28-14 rev.
7-26-11 rev.
2-15-95

GIRTH: SEE PATTERN: ITW-0143
BENDS: SEE PATTERN: ITW-0143

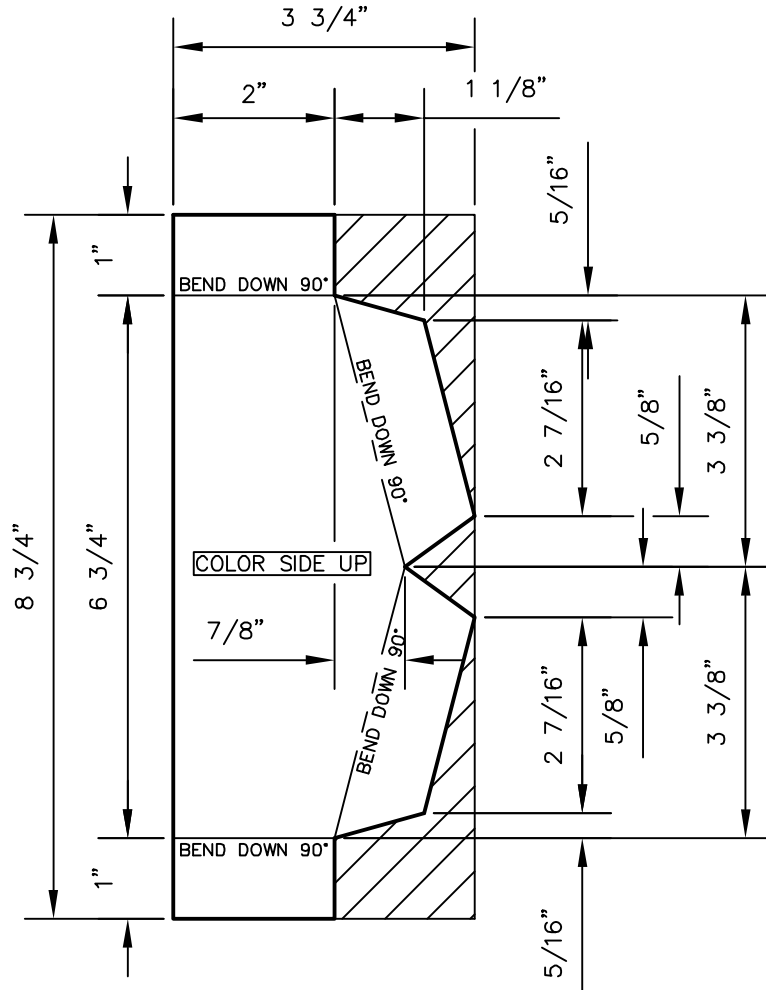

RAKE CLOSURE - PATTERN

PANEL PROFILES	GAUGE
MULTI-RIB	26
R-PANEL	26
U-PANEL	26
MIRAGE I	24 or 26
MIRAGE II	24 or 26
MEGA-RIB	26

5-28-14 rev.
 7-26-11 rev.
 2-15-95

GIRTH: 3 3/4" X 8 3/4"
 BENDS: AS SPECIFIED

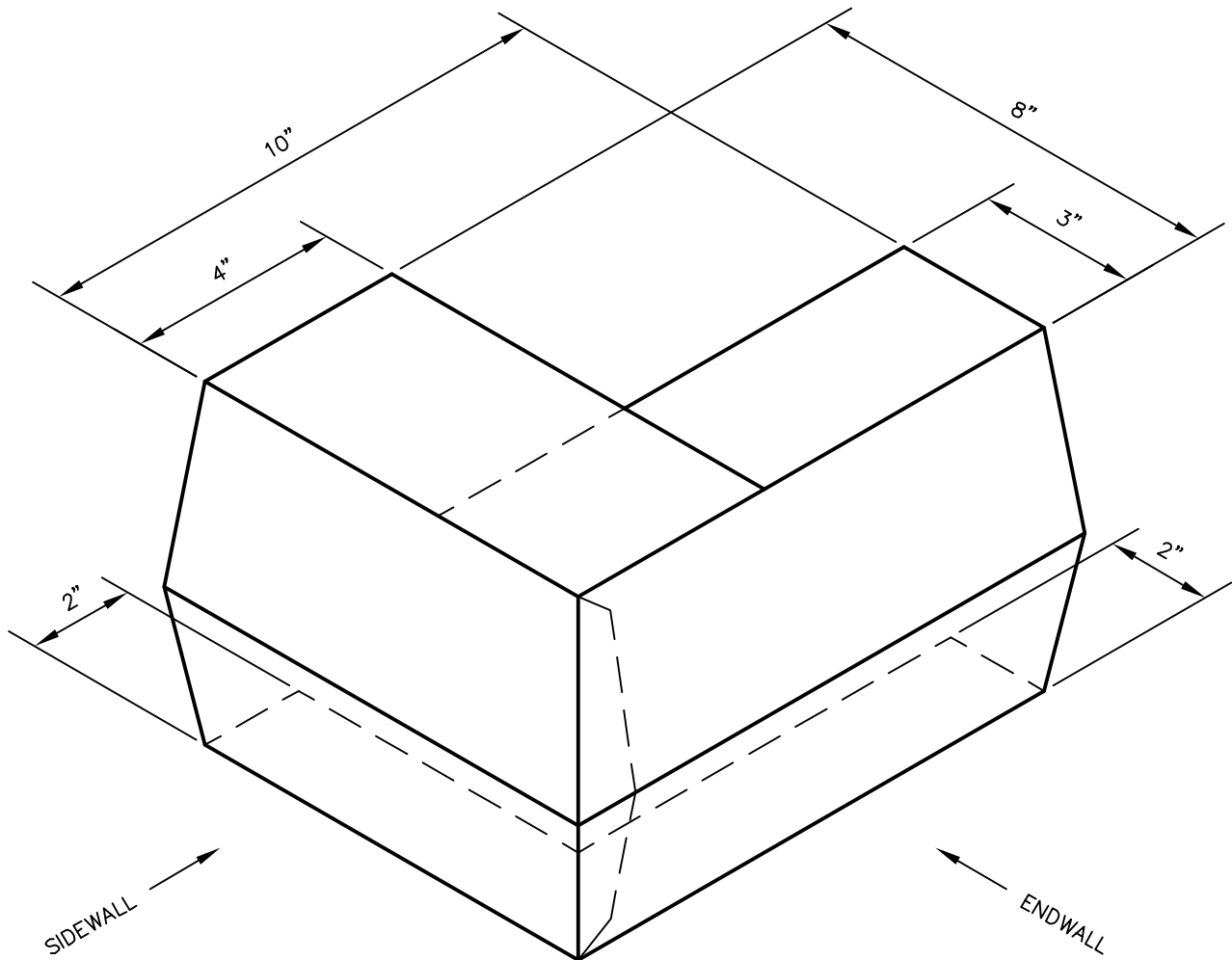

HIGH-SIDE CORNER BOX - FINISHED

(RIGHT HAND SHOWN - LEFT HAND OPP.)

PANEL PROFILES	GAUGE
MIRAGE	24 or 26
MIRAGE II	24 or 26
U-PANEL	26
MULTI-RIB	26
R-PANEL	26
MEGA-RIB	26

5-28-14 rev.
7-26-11 rev.
9-24-96

GIRTH: SEE PATTERN: ITW-0145 & ITW-0146
BENDS: SEE PATTERN: ITW-0145 & ITW-0146

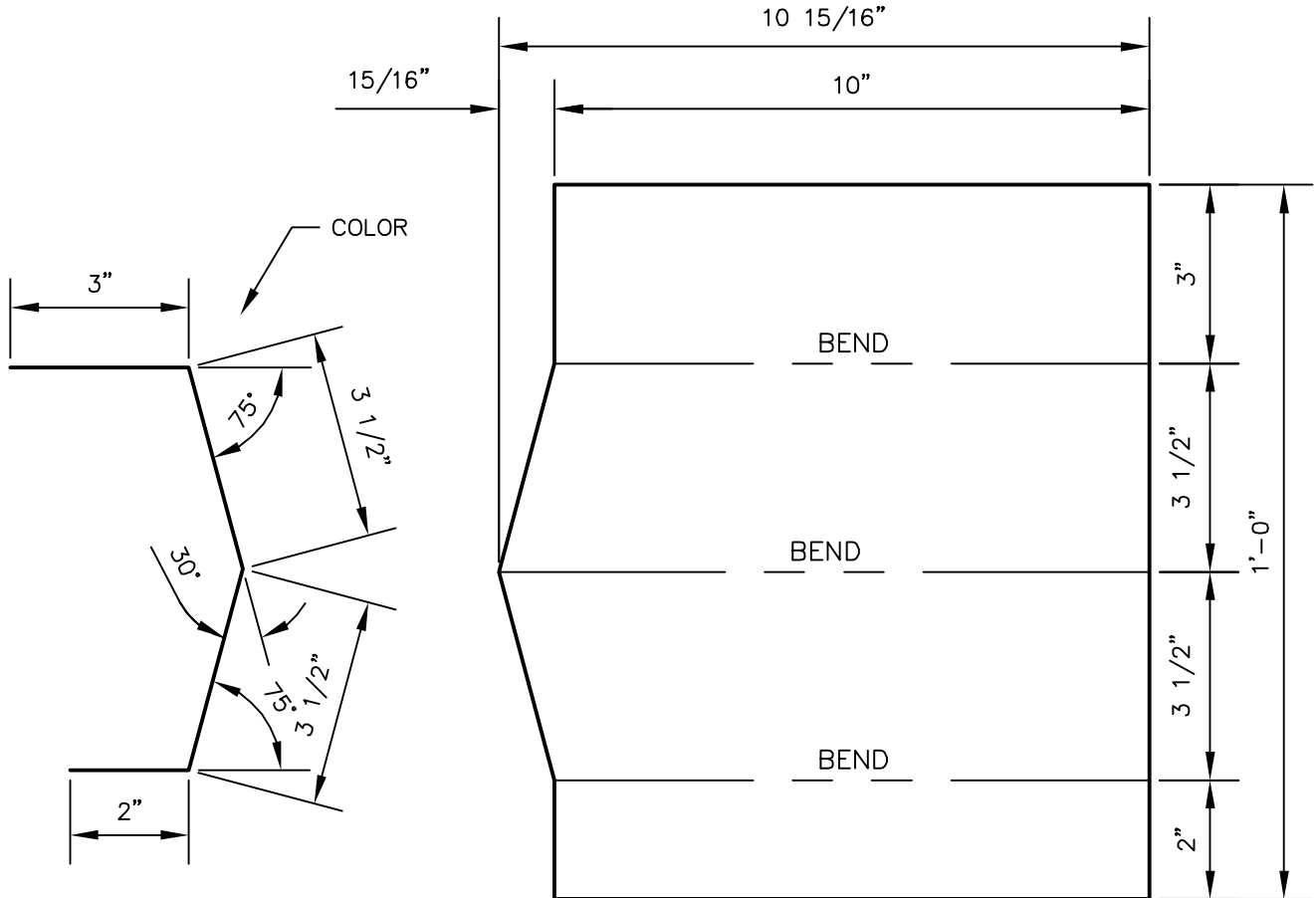

HIGH-SIDE CORNER BOX - PATTERN (ENDWALL)

(ASSEMBLE 1 RIGHT HAND & 1 LEFT HAND)
 (RIGHT HAND SHOWN - LEFT HAND OPP.)

PANEL PROFILES	GAUGE
MULTI-RIB	26
R-PANEL	26
U-PANEL	26
MIRAGE	24 or 26
MIRAGE II	24 or 26
MEGA-RIB	26

5-28-14 rev.
 7-26-11 rev.
 9-24-96

GIRTH: 10 15/16" X 1'-0"
 BENDS: AS SPECIFIED

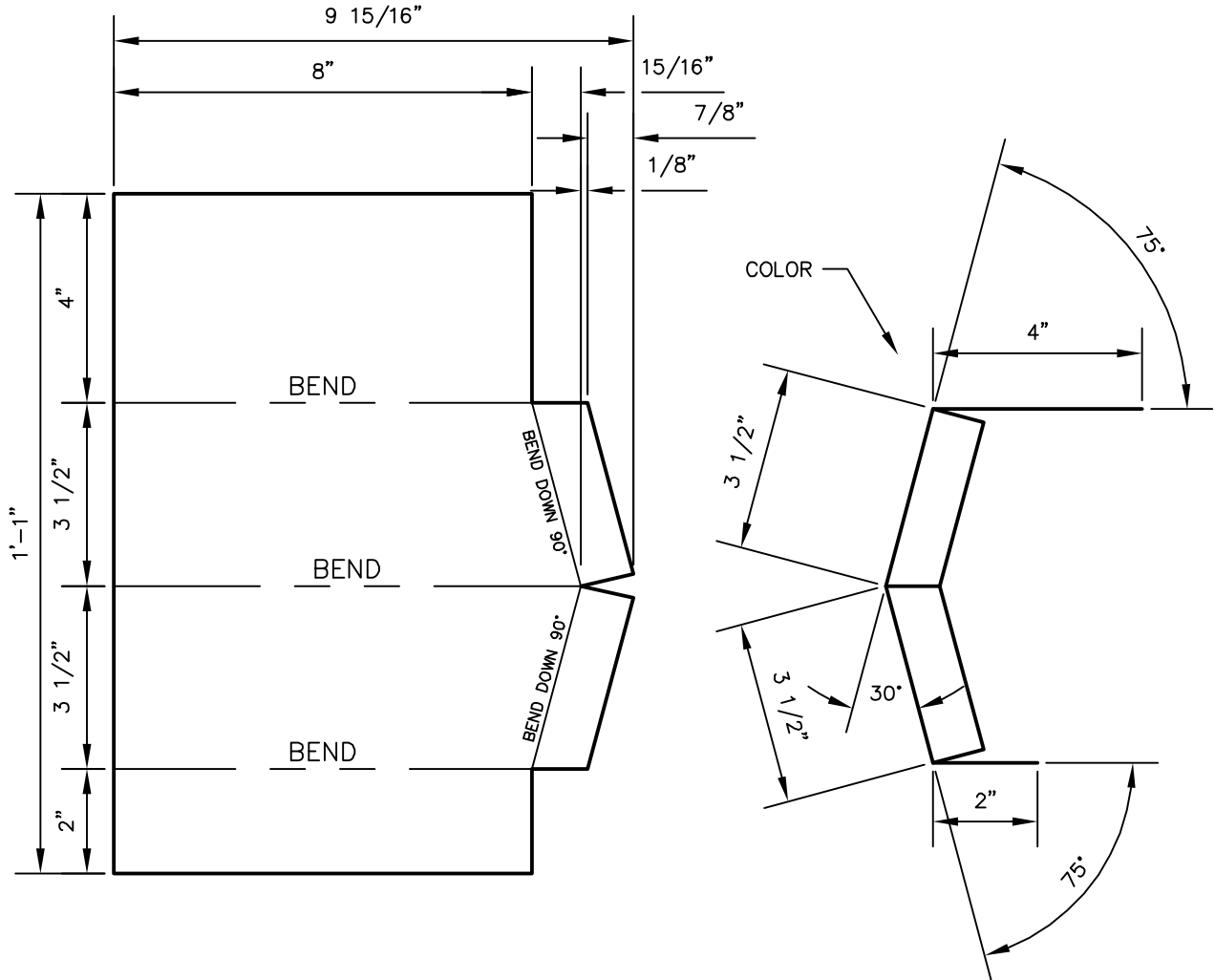

HIGH SIDE CORNER BOX - PATTERN (SIDEWALL)

(ASSEMBLE 1 RIGHT HAND & 1 LEFT HAND)
 (RIGHT HAND SHOWN & LEFT HAND OPP.)

PANEL PROFILES	GAUGE
MULTI-RIB	26
R-PANEL	26
U-PANEL	26
MIRAGE	24 or 26
MIRAGE II	24 or 26
MEGA-RIB	26

5-28-14 rev.
 7-26-11 rev.
 9-24-96

GIRTH: 9 15/16" X 1'-1"
 BENDS: AS SPECIFIED

223A

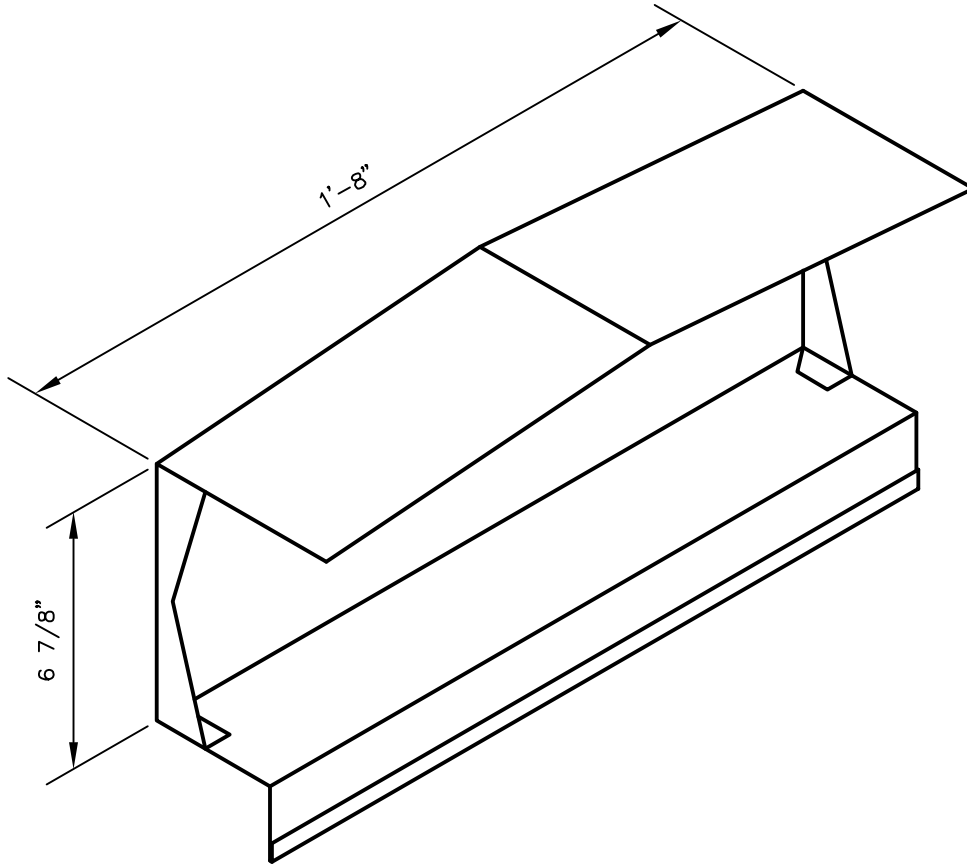

FIXED PEAK BOX ASSEMBLY - 1:12

PANEL PROFILES	GAUGE
MULTI-RIB	26
R-PANEL	26
U-PANEL	26
MEGA-RIB	26

9-04-13 rev.
7-26-11 rev.
2-20-04

GIRTH: SEE PATTERN: ITW-0148
BENDS: SEE PATTERN: ITW-0148

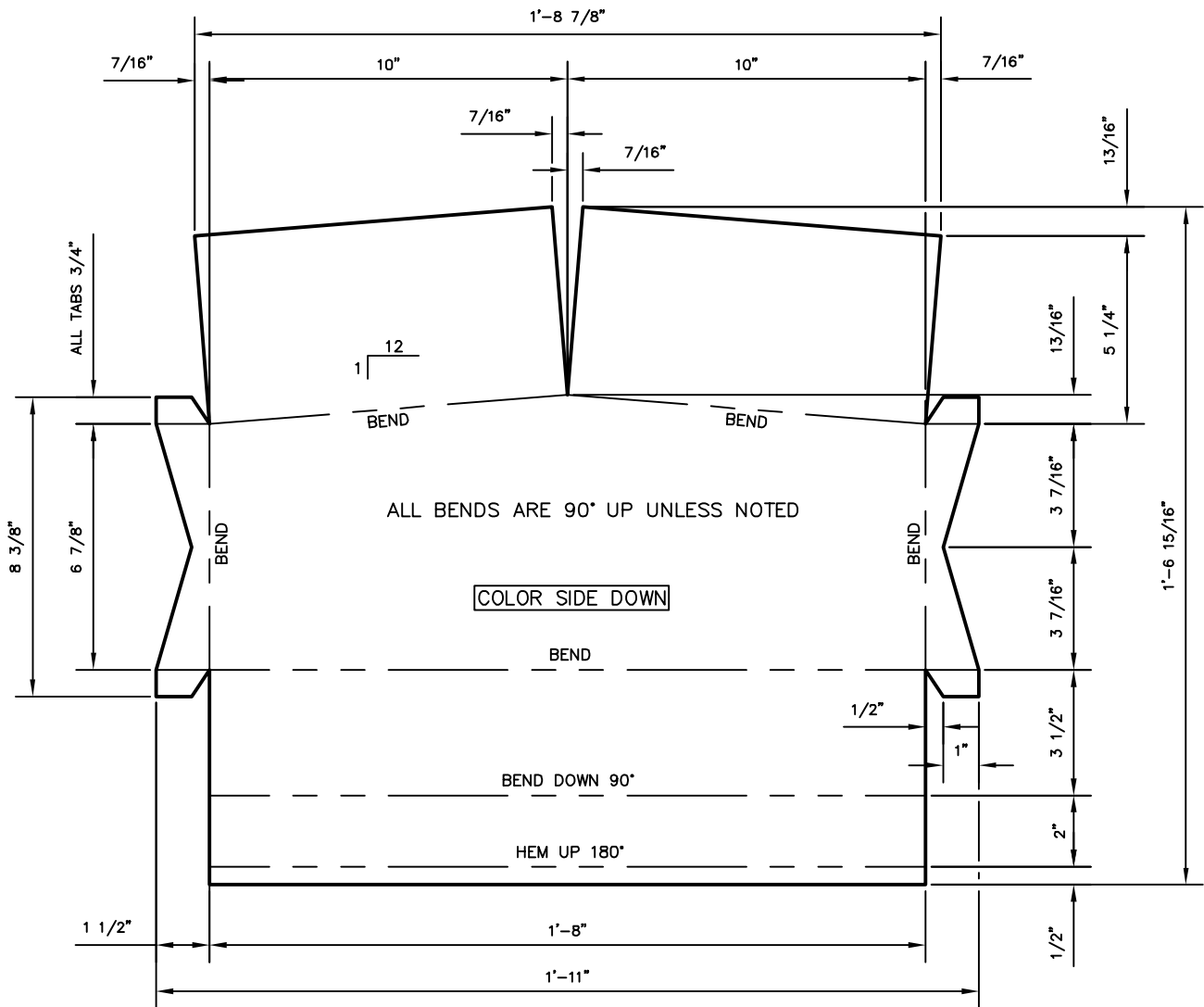

FIXED PEAK BOX PATTERN - 1:12

PANEL PROFILES	GAUGE
MULTI-RIB	26
R-PANEL	26
U-PANEL	26
MEGA-RIB	26

9-04-13 rev.
7-26-11 rev.
2-20-04

GIRTH: 1'-11 X 1'-6 15/16"
BENDS: 90° AND AS SPECIFIED

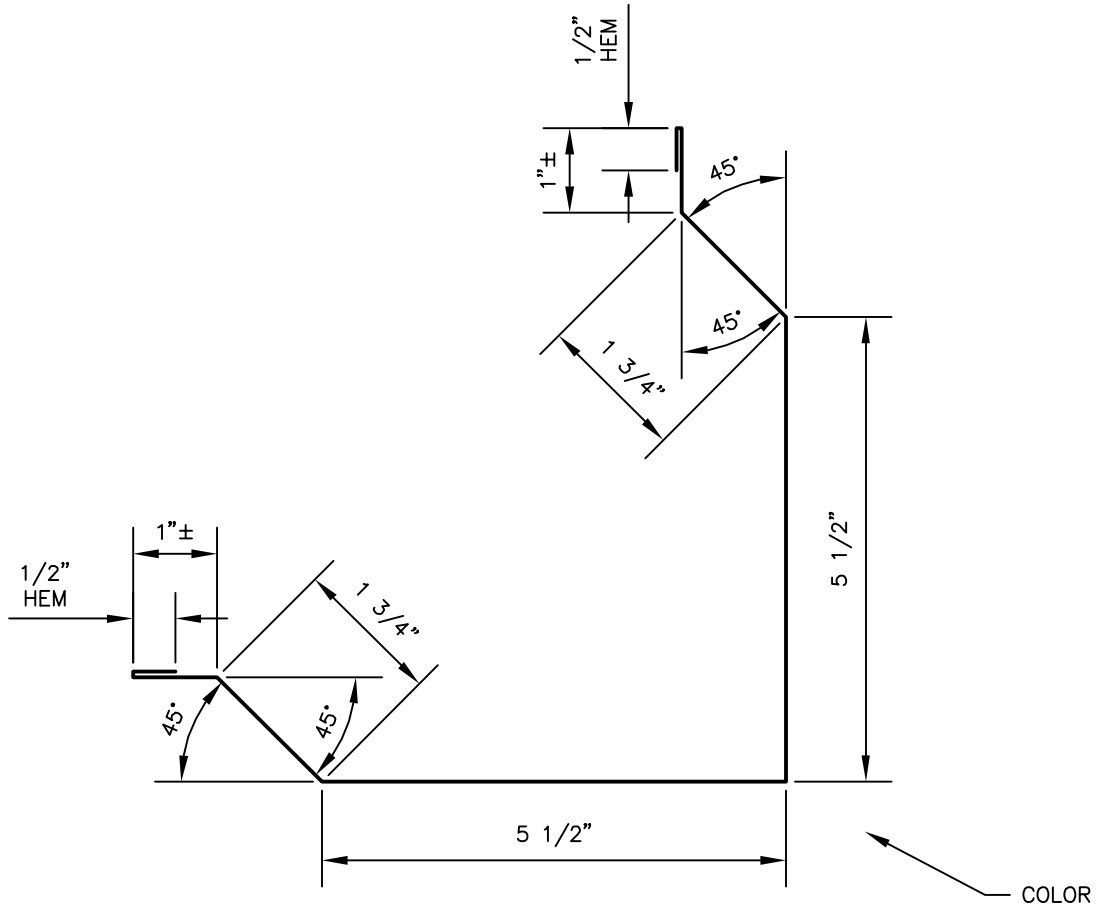

OUTSIDE CORNER TRIM

PANEL PROFILES	GAUGE
MULTI-V	26

6-18-13 rev.
10-13-11 rev.
9-03-96

GIRTH: 17 1/2"
BENDS: 90° AND AS SPECIFIED

225A

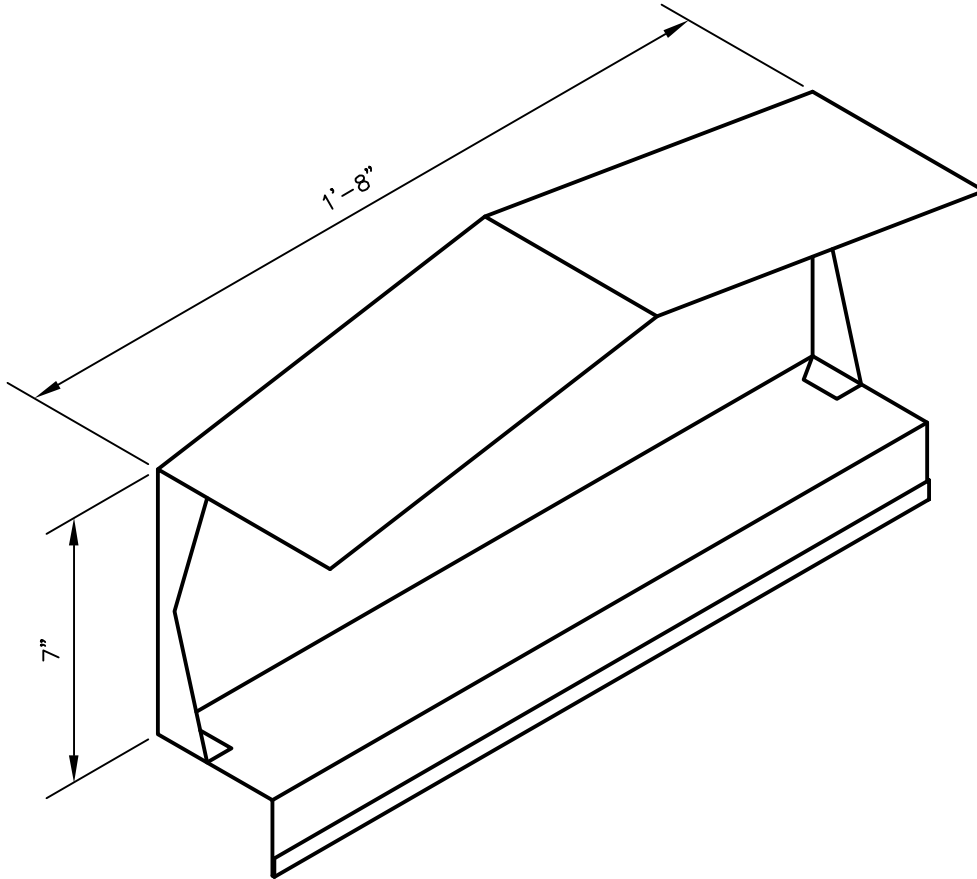

FIXED PEAK BOX ASSEMBLY - 2:12

PANEL PROFILES	GAUGE
MULTI-RIB	26
R-PANEL	26
U-PANEL	26
MEGA-RIB	26

8-26-13 rev.
7-26-11 rev.
2-20-04

GIRTH: SEE PATTERN: ITW-0152
BENDS: SEE PATTERN: ITW-0152

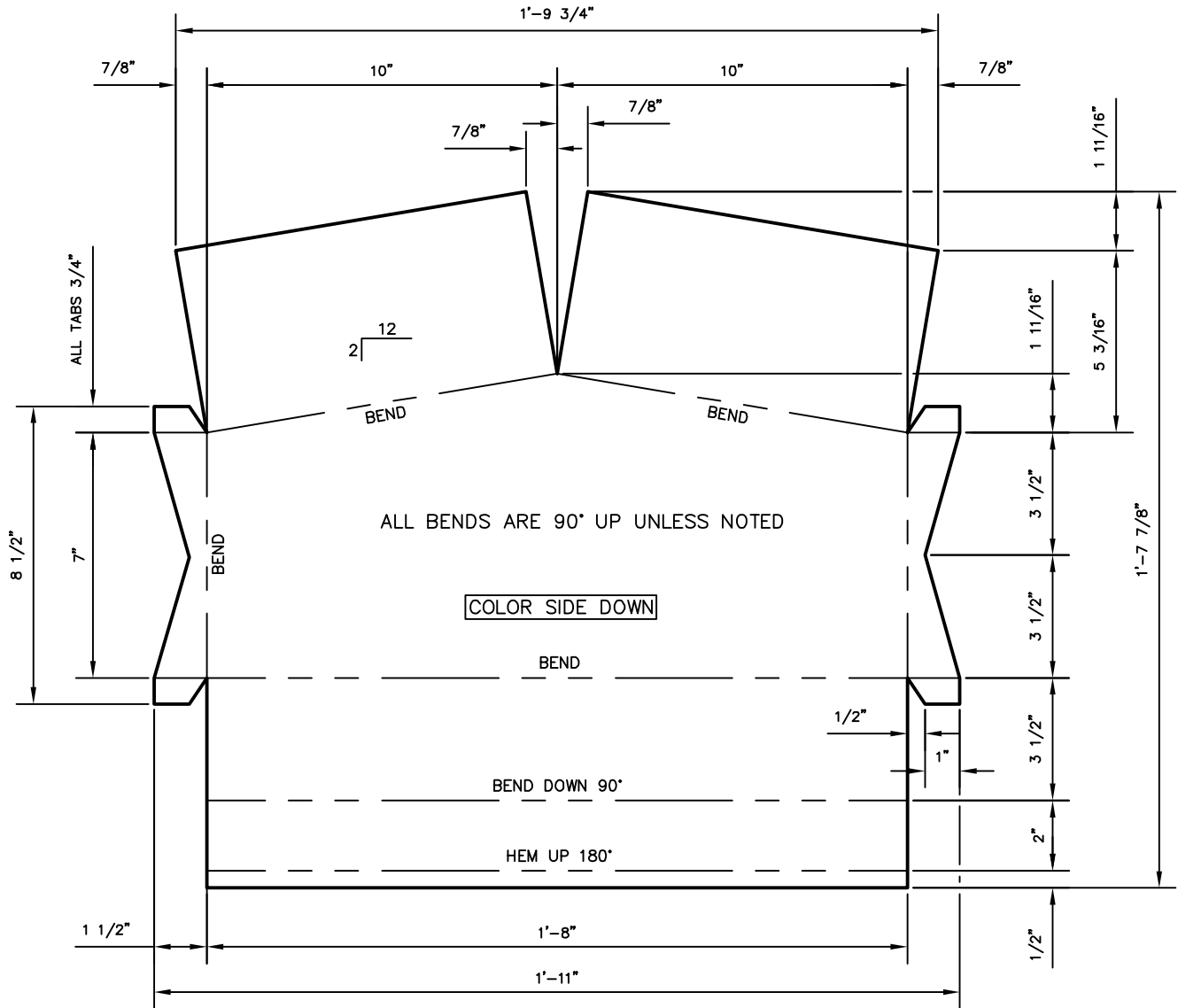

FIXED PEAK BOX PATTERN - 2:12

PANEL PROFILES	GAUGE
MULTI-RIB	26
R-PANEL	26
U-PANEL	26
MEGA-RIB	26

9-04-13 rev.
 7-26-11 rev.
 2-20-04

GIRTH: 1'-11" X 1'-7 7/8"
 BENDS: 90° AND AS SPECIFIED

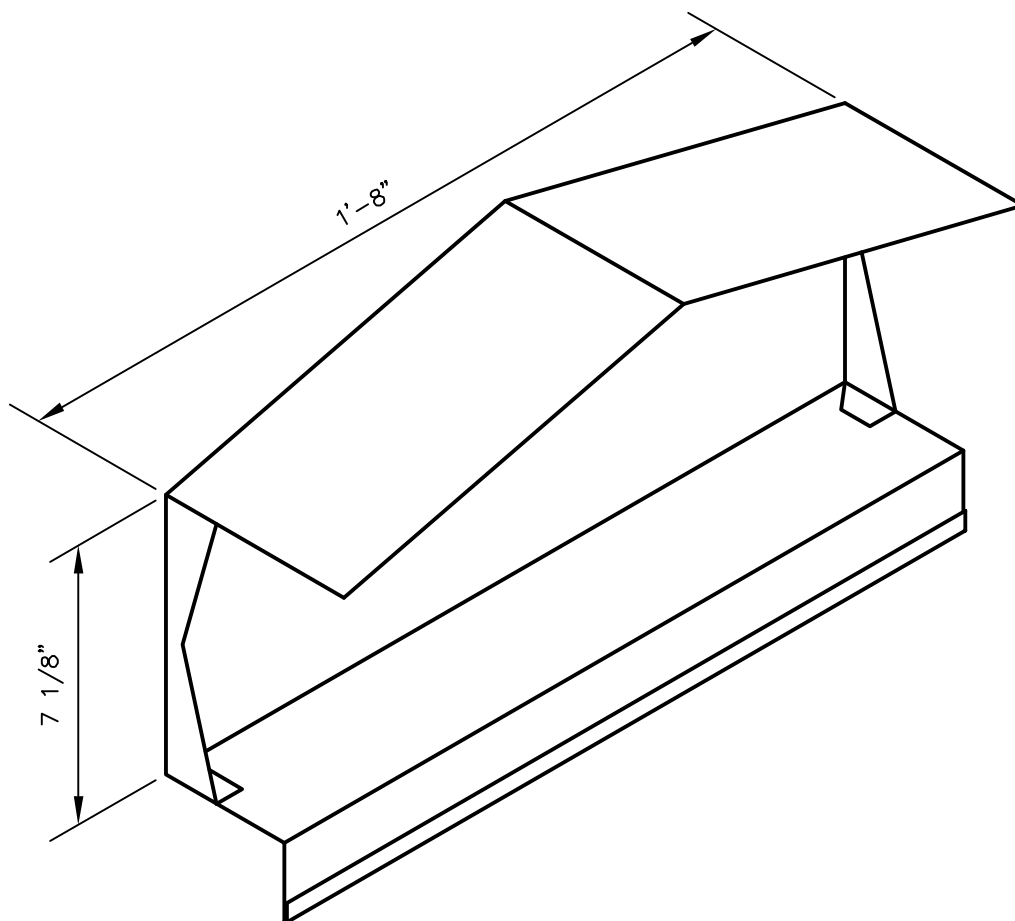

FIXED PEAK BOX ASSEMBLY - 3:12

PANEL PROFILES	GAUGE
MULTI-RIB	26
R-PANEL	26
U-PANEL	26
MEGA-RIB	26

8-26-13 rev.
 7-26-11 rev.
 2-20-04

GIRTH: SEE PATTERN: ITW-0154
 BENDS: SEE PATTERN: ITW-0154

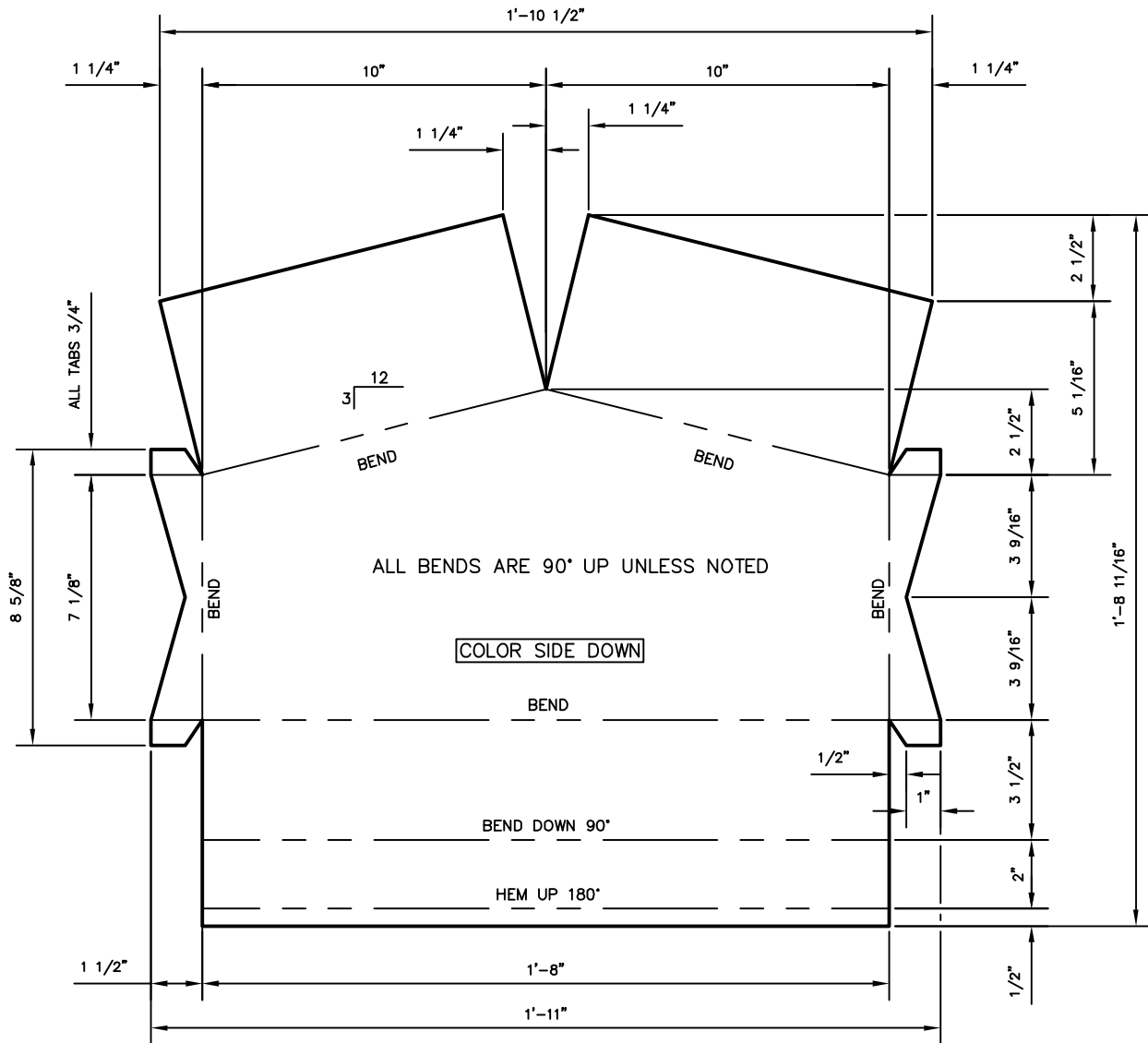

FIXED PEAK BOX PATTERN - 3:12

PANEL PROFILES	GAUGE
MULTI-RIB	26
R-PANEL	26
U-PANEL	26
MEGA-RIB	26

8-26-13 rev.
 7-26-11 rev.
 2-20-04

GIRTH: 1'-11" X 1'-8 11/16"
 BENDS: 90° AND AS SPECIFIED

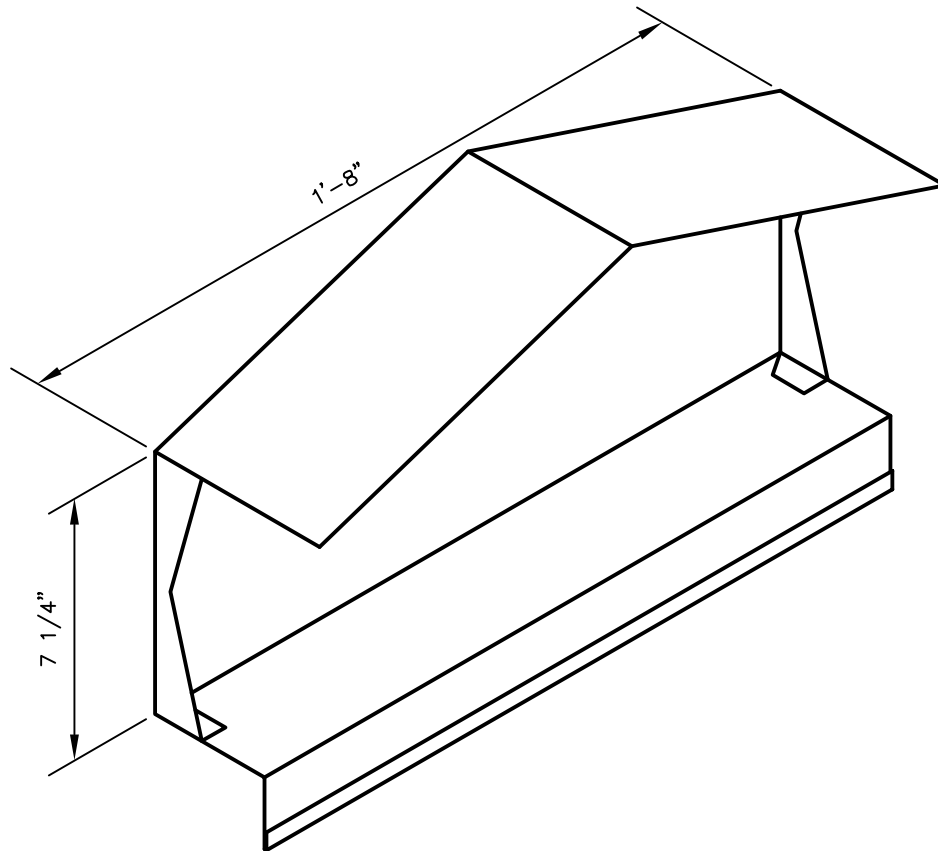

FIXED PEAK BOX ASSEMBLY - 4:12

PANEL PROFILES	GAUGE
MULTI-RIB	26
R-PANEL	26
U-PANEL	26
MEGA-RIB	26

8-26-13 rev.
7-26-11 rev.
2-20-04

GIRTH: SEE PATTERN: ITW-0156
BENDS: SEE PATTERN: ITW-0156

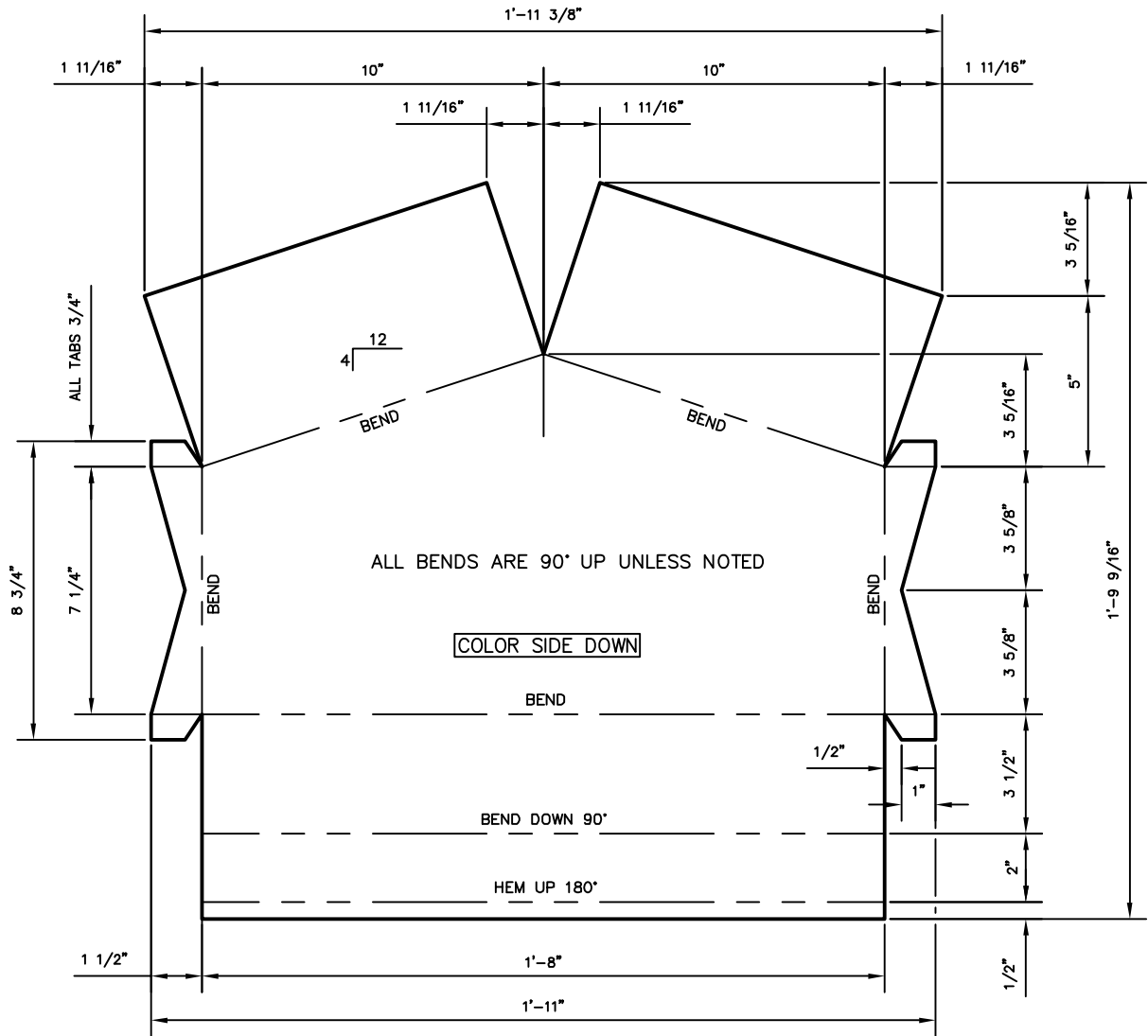

FIXED PEAK BOX PATTERN - 4:12

PANEL PROFILES	GAUGE
MULTI-RIB	26
R-PANEL	26
U-PANEL	26
MEGA-RIB	26

9-04-13 rev.
 7-26-11 rev.
 2-20-04

GIRTH: 1'-11 3/8" X 1'-9 9/16"
 BENDS: 90° AND AS SPECIFIED

231A

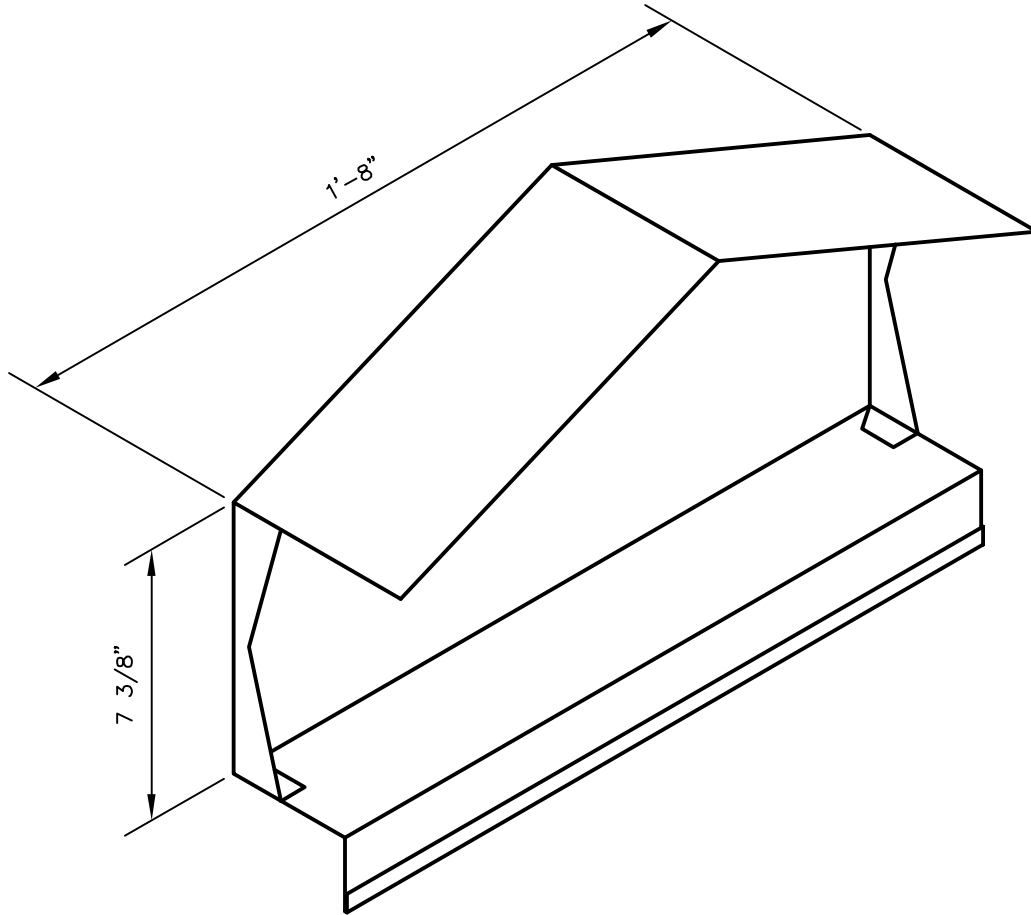

FIXED PEAK BOX ASSEMBLY - 5:12

PANEL PROFILES	GAUGE
MULTI-RIB	26
R-PANEL	26
U-PANEL	26
MEGA-RIB	26

9-04-13 rev.
7-26-11 rev.
2-20-04

GIRTH: SEE PATTERN: ITW-0158
BENDS: SEE PATTERN: ITW-0158

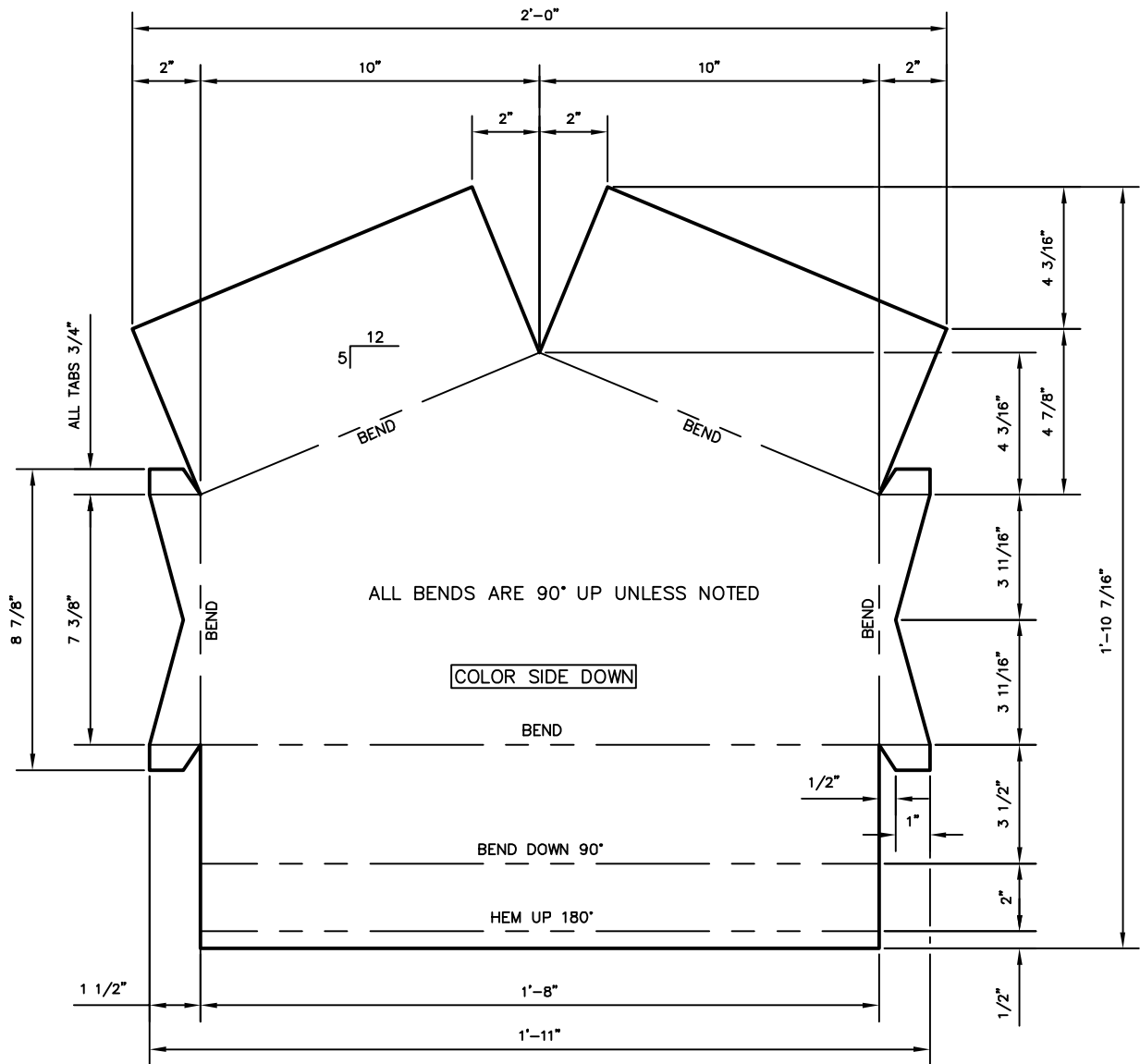

FIXED PEAK BOX PATTERN - 5:12

PANEL PROFILES	GAUGE
MULTI-RIB	26
R-PANEL	26
U-PANEL	26
MEGA-RIB	26

9-04-13 rev.
 7-26-11 rev.
 2-20-04

GIRTH: 2'-0" X 1'-10 7/16"
 BENDS: 90° AND AS SPECIFIED

233A

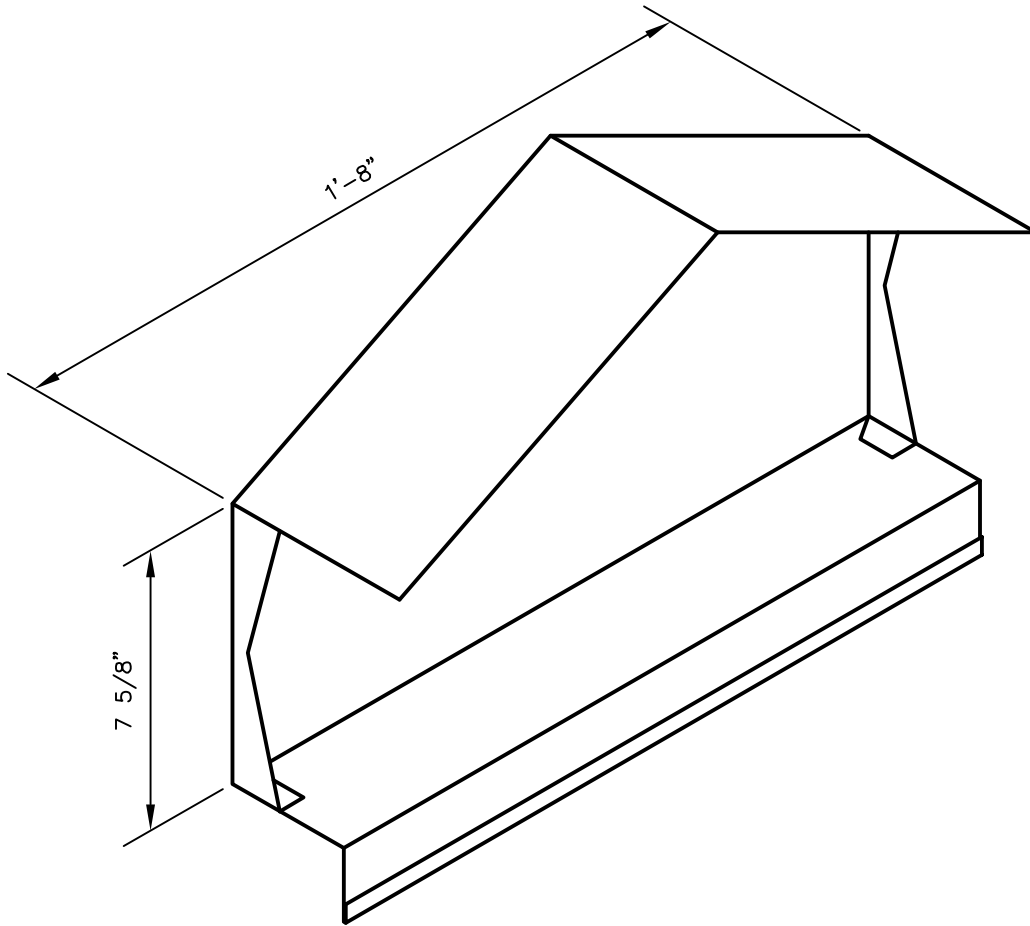

FIXED PEAK BOX ASSEMBLY - 6:12

PANEL PROFILES	GAUGE
MULTI-RIB	26
R-PANEL	26
U-PANEL	26
MEGA-RIB	26

9-04-13 rev.
7-26-11 rev.
2-20-04

GIRTH: SEE PATTERN: ITW-0160
BENDS: SEE PATTERN: ITW-0160

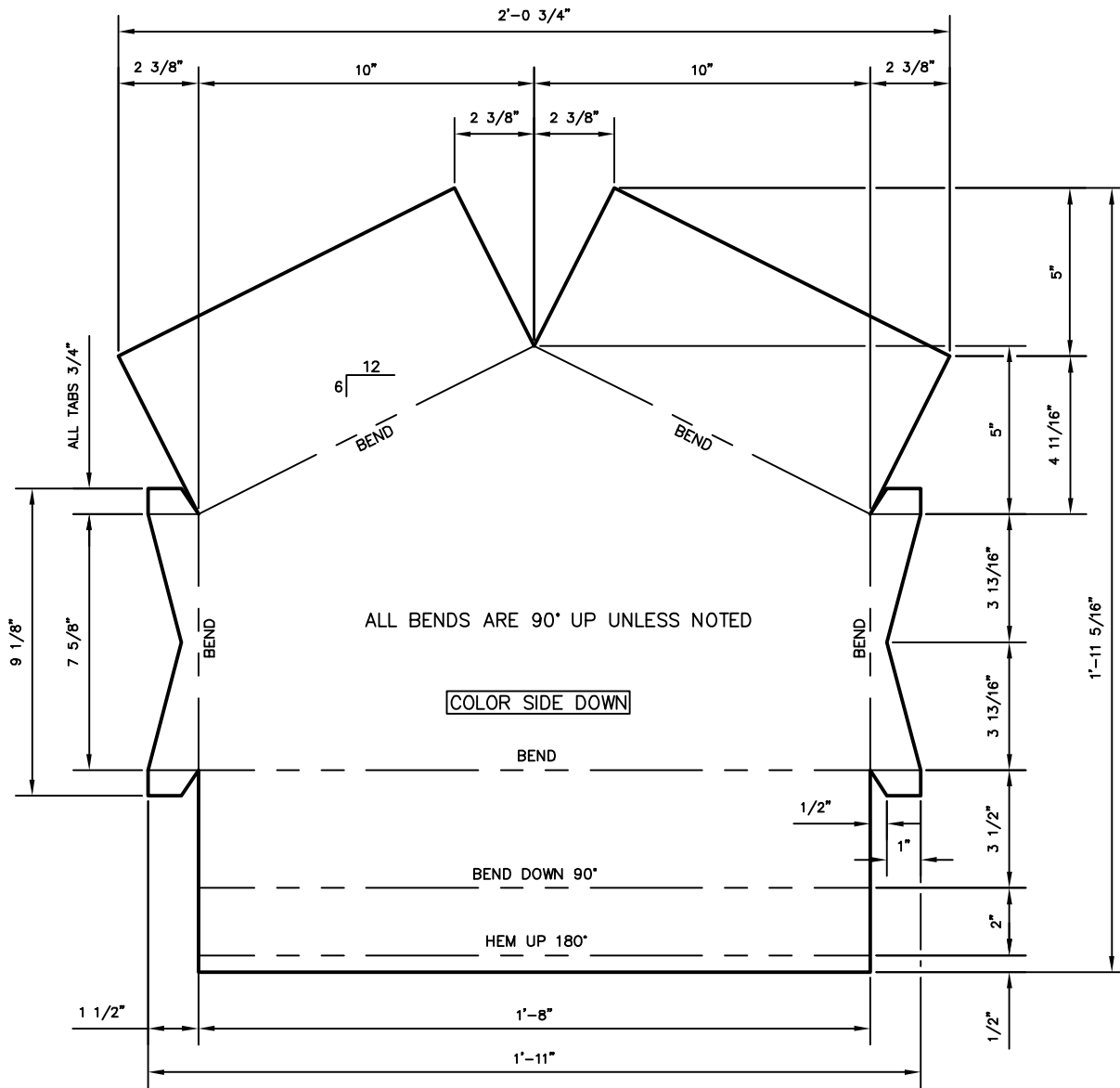

FIXED PEAK BOX PATTERN - 6:12

PANEL PROFILES	GAUGE
MULTI-RIB	26
R-PANEL	26
U-PANEL	26
MEGA-RIB	26

9-04-13 rev.
 7-26-11 rev.
 2-20-04

GIRTH: 2'-0 3/4" X 1'-11 5/16"
 BENDS: 90° AND AS SPECIFIED

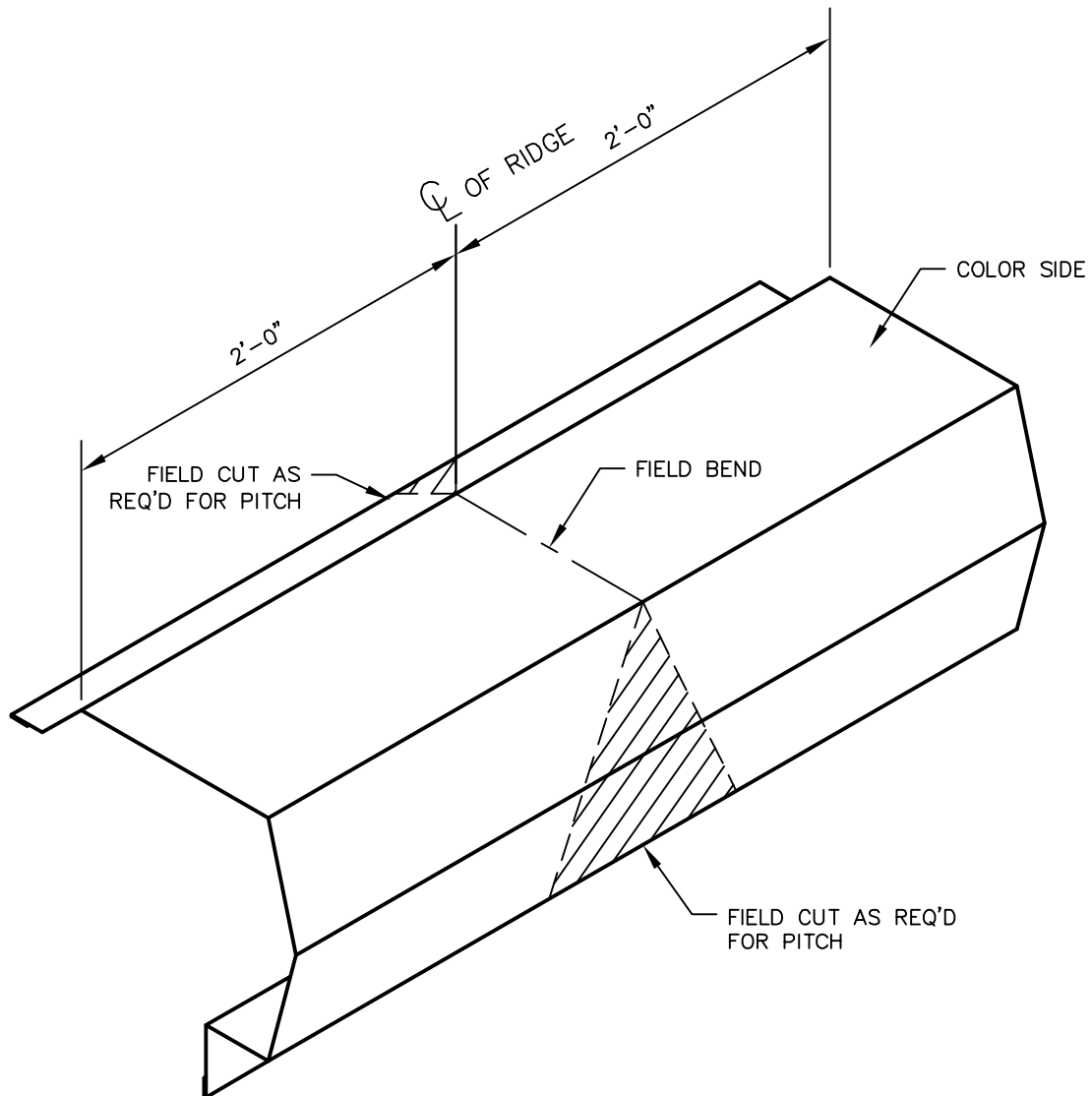

VARIABLE PEAK BOX ASSEMBLY

PANEL PROFILES	GAUGE
MULTI-RIB	26
R-PANEL	26
U-PANEL	26
MEGA-RIB	26

9-04-13 rev.
7-26-11 rev.
2-20-04

GIRTH: SEE PATTERN: ITW-0162
BENDS: SEE PATTERN: ITW-0162

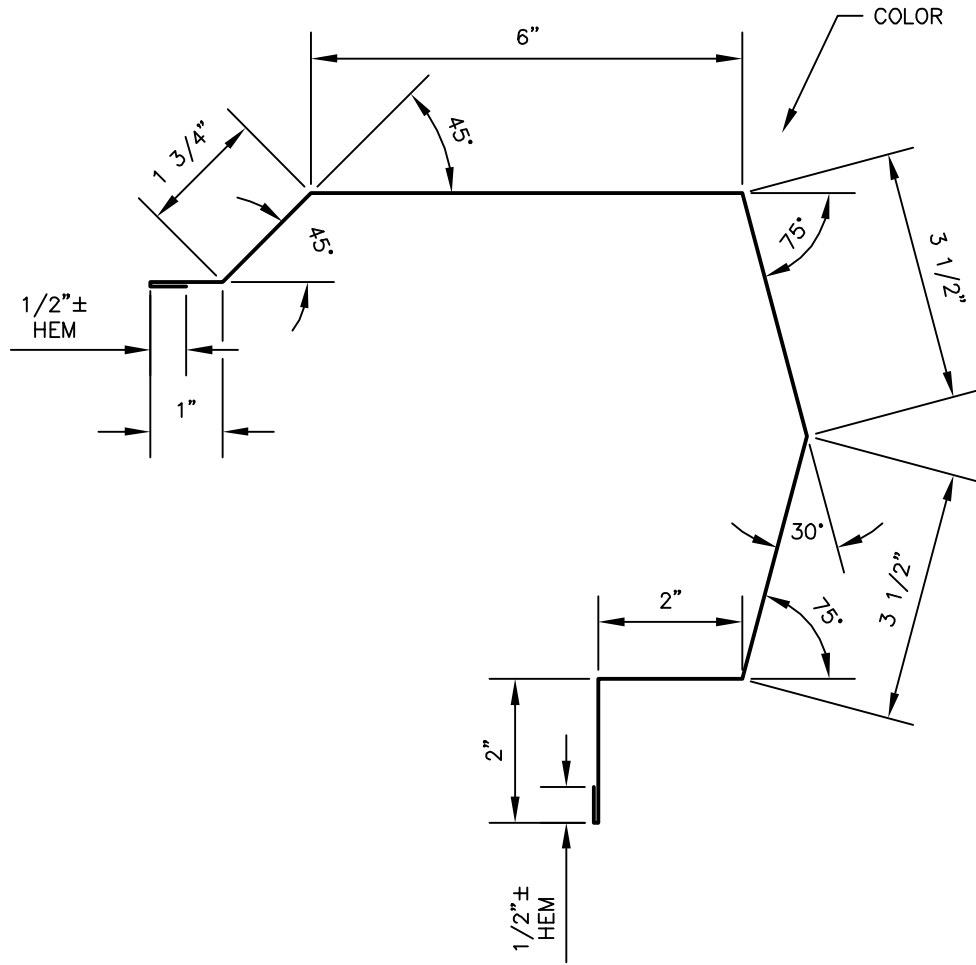

VARIABLE PEAK BOX PATTERN

PANEL PROFILES	GAUGE
MULTI-RIB	26
R-PANEL	26
U-PANEL	26
MEGA-RIB	26

9-04-13 rev.
 7-26-11 rev.
 2-20-04

GIRTH: 1'-8 3/4" X 4'-0" LONG
 BENDS: 90° AND AS SPECIFIED

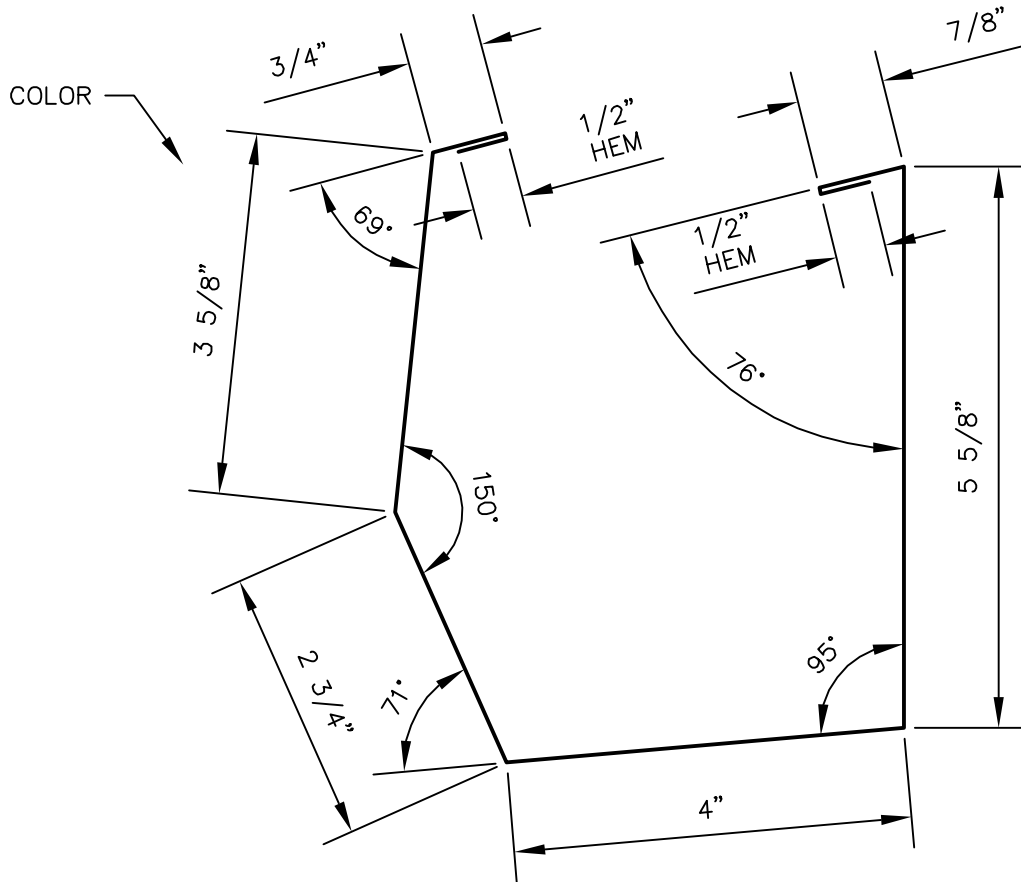

STANDARD GUTTER (2:12 - 4:12)

PANEL PROFILES	GAUGE
MULTI-RIB	26
R-PANEL	26
MEGA-RIB	26

6-18-13 rev.
 7-26-11 rev.
 2-20-04

GIRTH: 18 5/8"
 BENDS: AS SPECIFIED

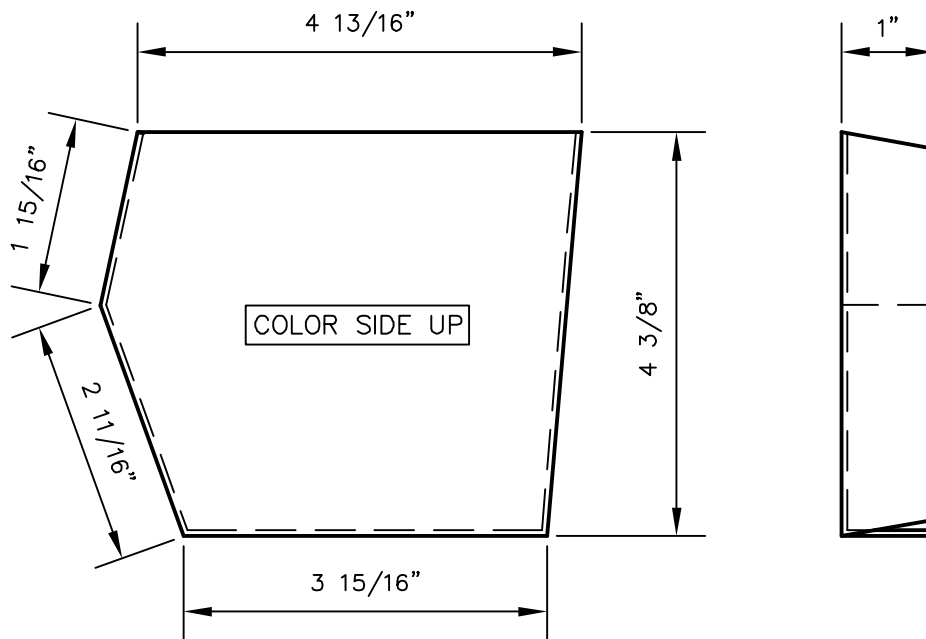

STANDARD GUTTER END CAP - ASSEMBLY

(2:12 - 4:12 PITCHES)

PANEL PROFILES	GAUGE
MULTI-RIB	26
R-PANEL	26
MEGA-RIB	26

6-18-13 rev.
7-26-11 rev.
9-10-07

GIRTH: SEE PATTERN: ITW-0165
BENDS: SEE PATTERN: ITW-0165

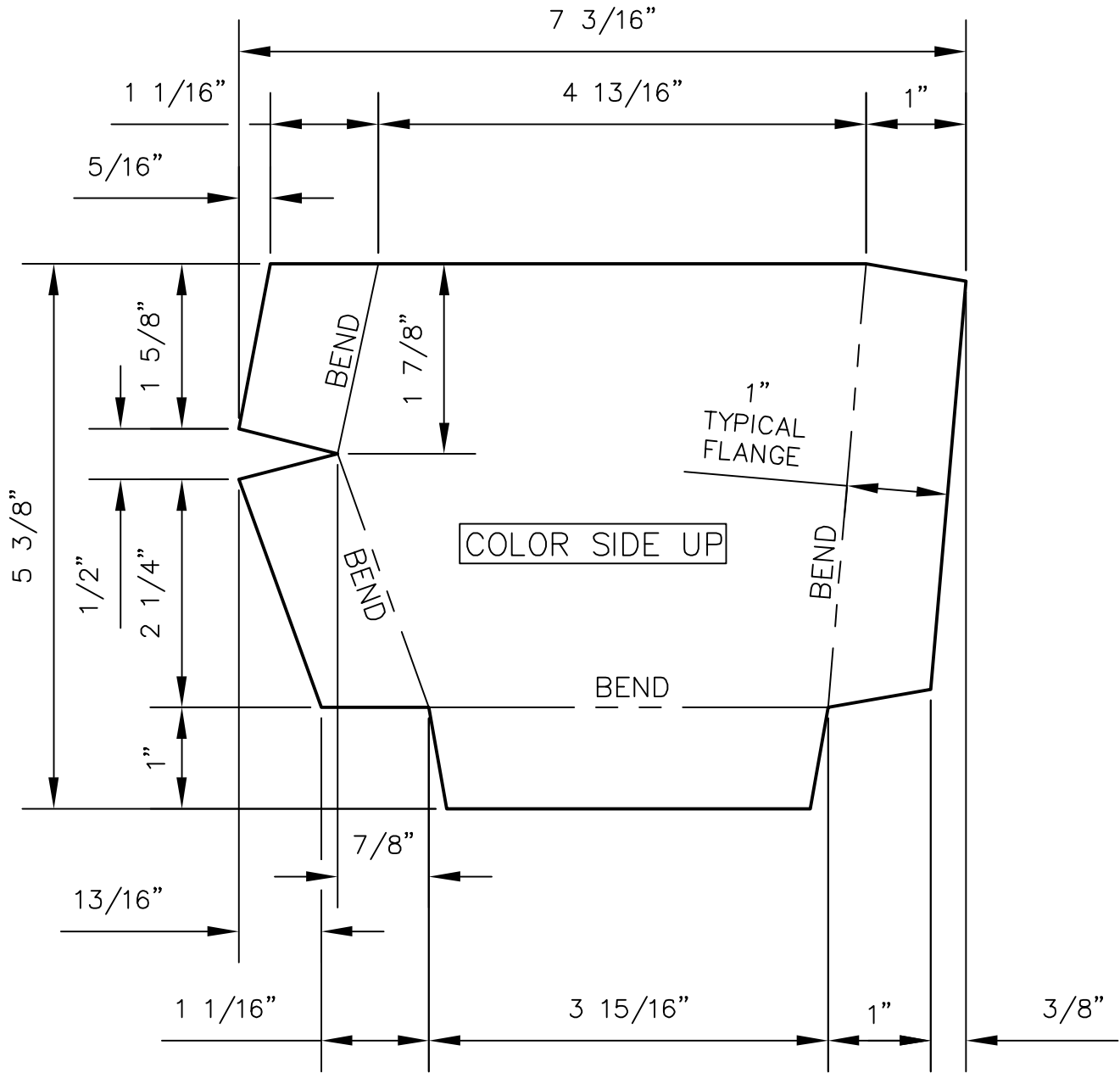

STANDARD GUTTER END CAP - PATTERN

(2:12 - 4:12 PITCHES)

PANEL PROFILES	GAUGE
MULTI-RIB	26
R-PANEL	26
MEGA-RIB	26

6-24-13 rev.
 9-23-11 rev.
 9-10-07

GIRTH: 7 3/16" X 5 3/8"
 BENDS: 90° DOWN AND AS SPECIFIED

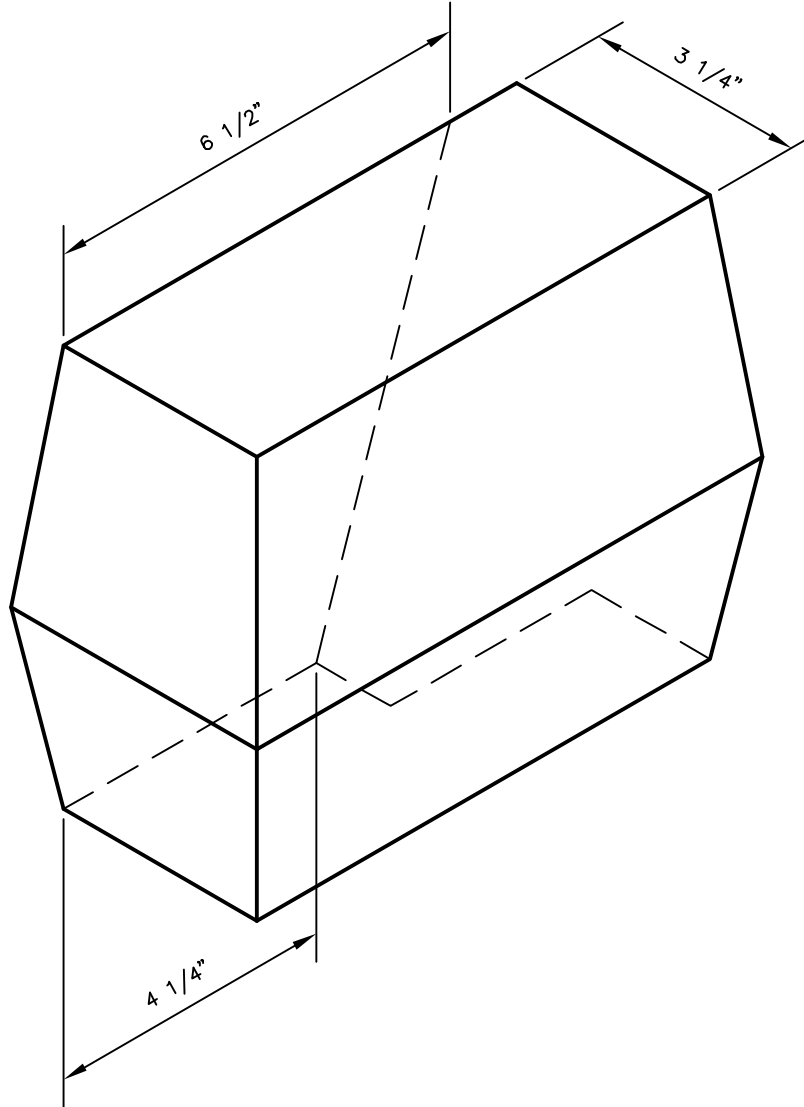

GUTTER CORNER BOX - (FINISHED)

(RIGHT HAND SHOWN - LEFT HAND OPP.)

(FOR 2:12 TO 4:12 PITCHES)

PANEL PROFILES	GAUGE
MULTI-RIB	24 or 26
R-PANEL	24 or 26
MEGA-RIB	24 or 26
U-PANEL	24 or 26

6-10-19 rev.
 8-27-14 rev.
 6-24-13 rev.
 7-26-11 rev.
 2-20-04

GIRTH: SEE PATTERN: ITW-0167
 BENDS: SEE PATTEN: ITW-0167

178B

178C

178D

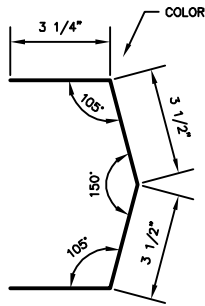

MAT'L: 26 GA.
GIRTH: 13 1/2" X 9 1/4"
BENDS: AS SPECIFIED

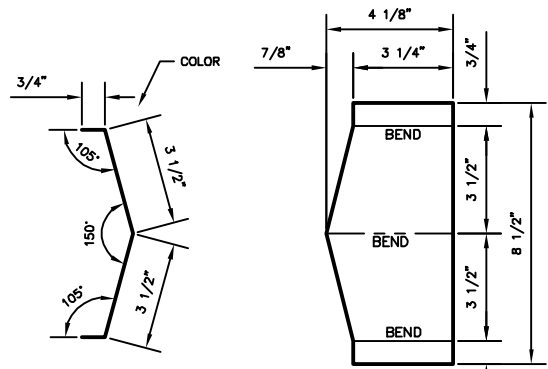
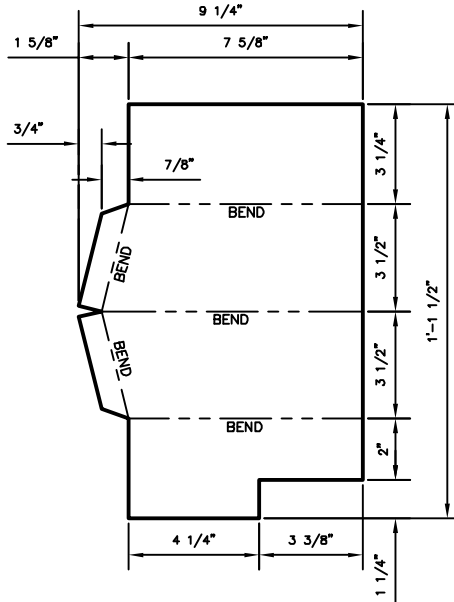

MAT'L: 26 GA.
GIRTH: 8 1/2" X 4 1/8"
BENDS: AS SPECIFIED

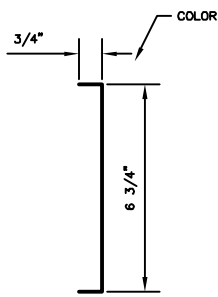

MAT'L: 26 GA.
GIRTH: 8 1/8" X 8 1/4"
BENDS: 90°

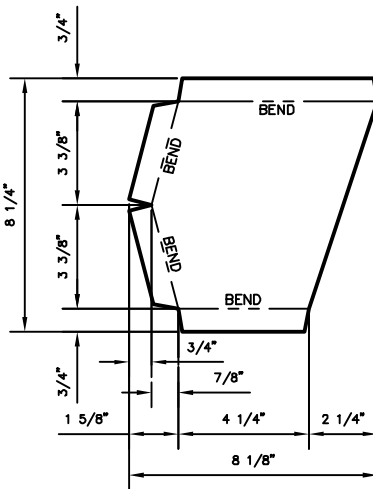

PANEL PROFILES	GAUGE
MULTI-RIB	24 or 26
R-PANEL	24 or 26
MEGA-RIB	24 or 26
U-PANEL	24 or 26

GUTTER CORNER BOX - PATTERNS

(RIGHT HAND SHOWN - LEFT HAND OPP.)
(2:12 - 4:12 PITCHES)

- 6-10-19 rev.
- 8-27-14 rev.
- 6-24-13 rev.
- 7-26-11 rev.
- 9-10-07

GIRTH: SEE ABOVE
BENDS: SEE ABOVE
SEE FINISHED: ITW-0166

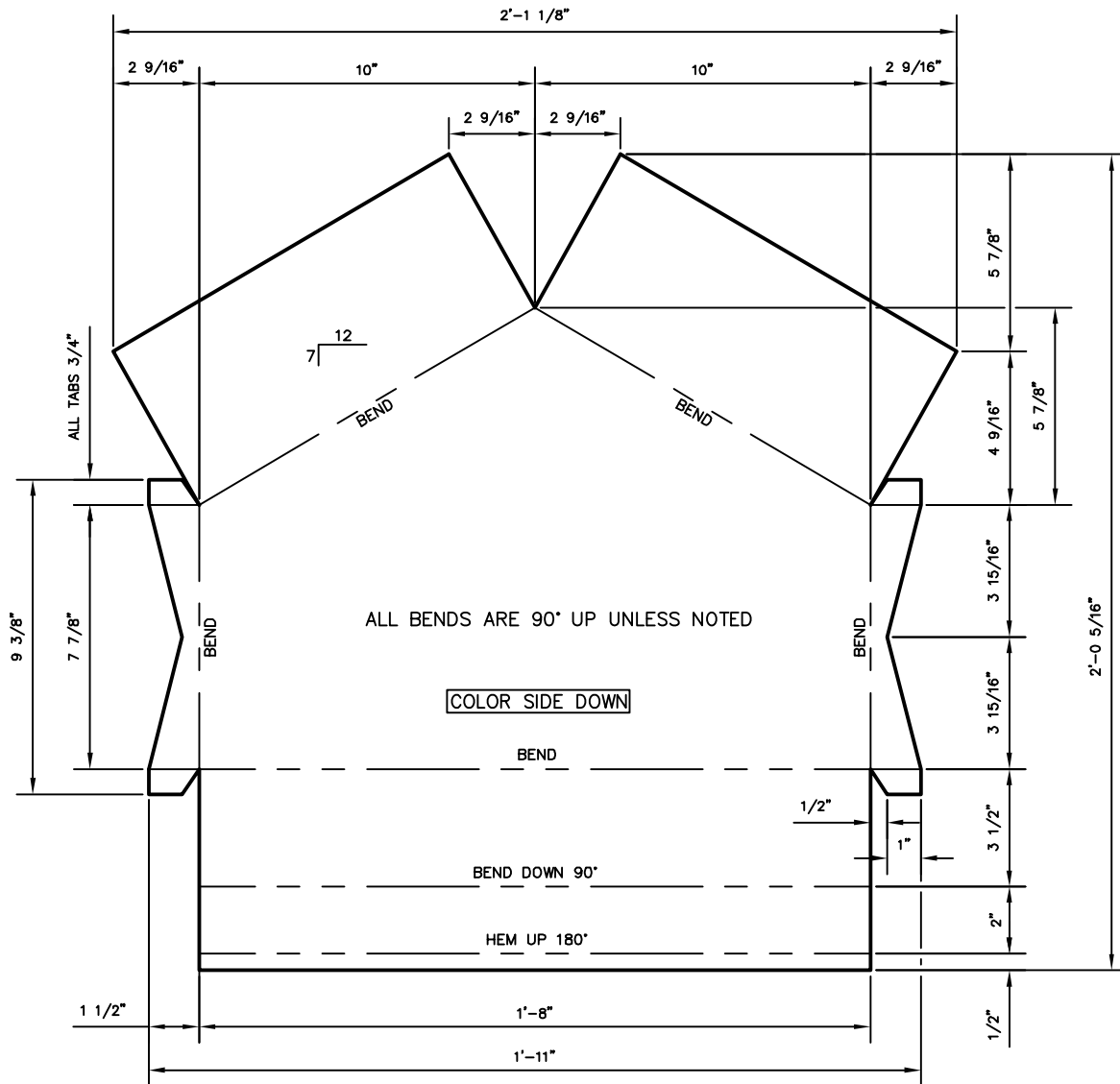

FIXED PEAK BOX - 7:12 (PATTERN)

PANEL PROFILES	GAUGE
MULTI-RIB	26
R-PANEL	26
U-PANEL	26
MEGA-RIB	26

9-04-13 rev.
 7-26-11 rev.
 1-13-09

GIRTH: 2'-1 1/8" X 2'-0 5/16"
 BENDS: 90° AND AS SPECIFIED
 SEE FINISHED: ITW-0169

235A

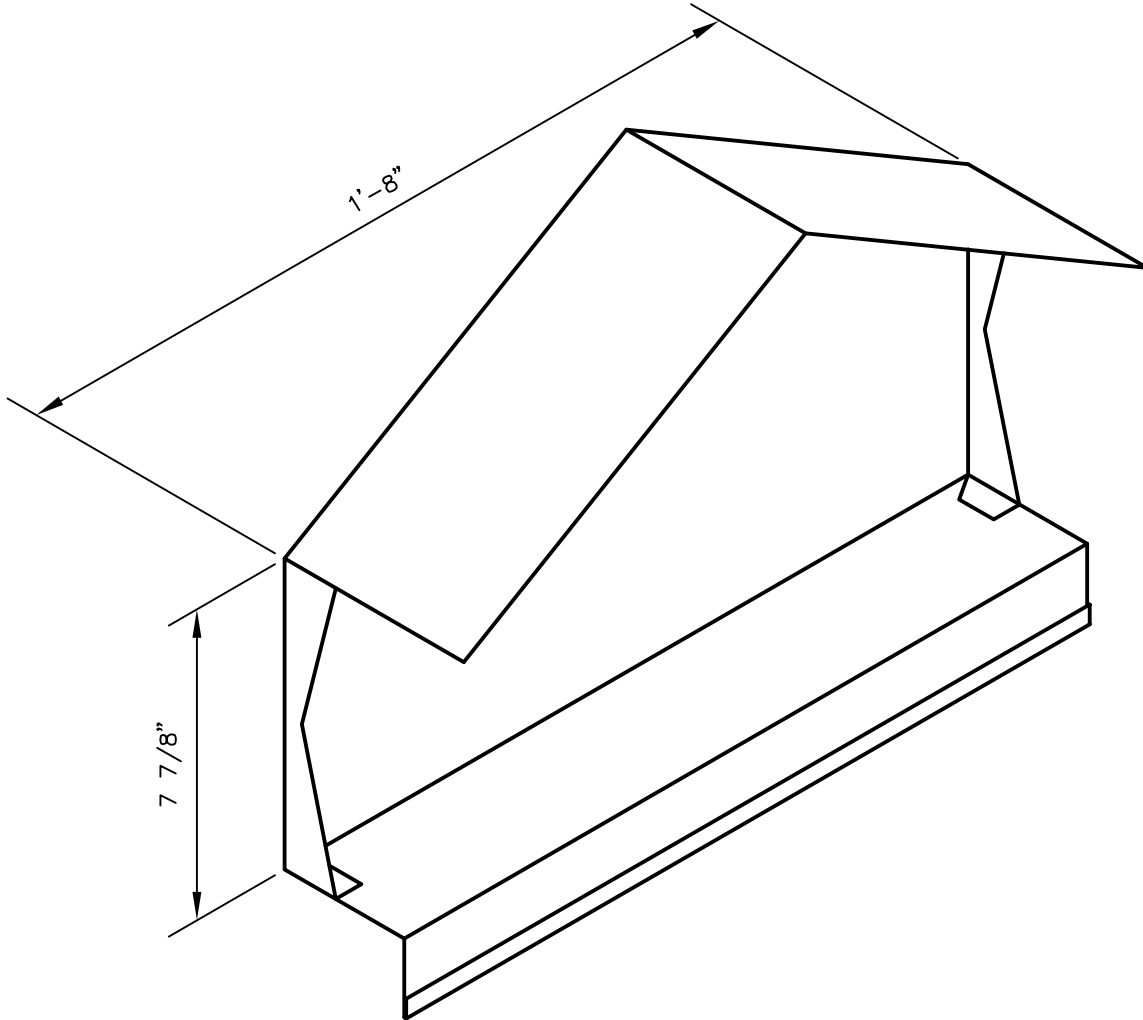

FIXED PEAK BOX - 7:12 (FINISHED)

PANEL PROFILES	GAUGE
MULTI-RIB	26
R-PANEL	26
U-PANEL	26
MEGA-RIB	26

9-04-13 rev.
7-26-11 rev.
2-20-04

GIRTH: SEE PATTERN: ITW-0168
BENDS: SEE PATTERN: ITW-0168

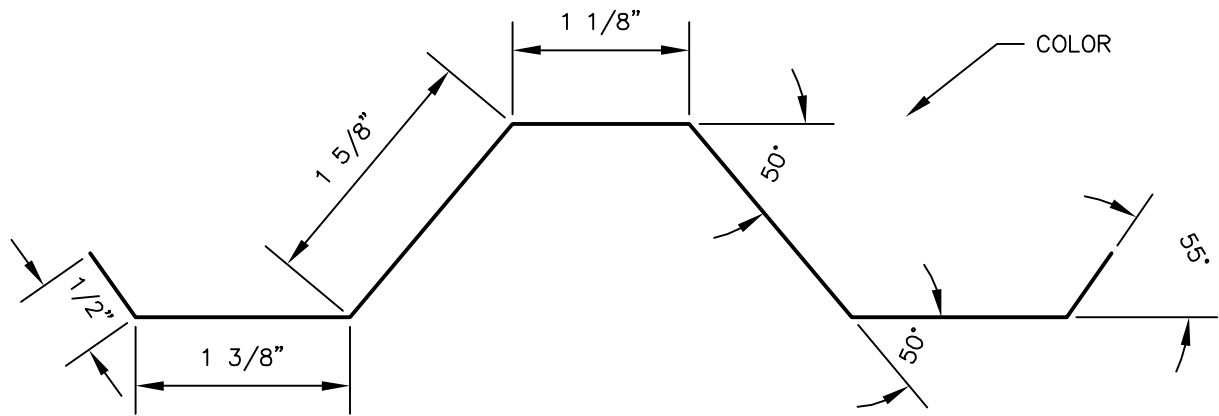

SKYLIGHT SIDE TRIM - UL90

(FOR USE WITH R-PANEL)

PANEL PROFILES	GAUGE
R-PANEL	26

GIRTH: 8 1/8"
BENDS: AS SPECIFIED

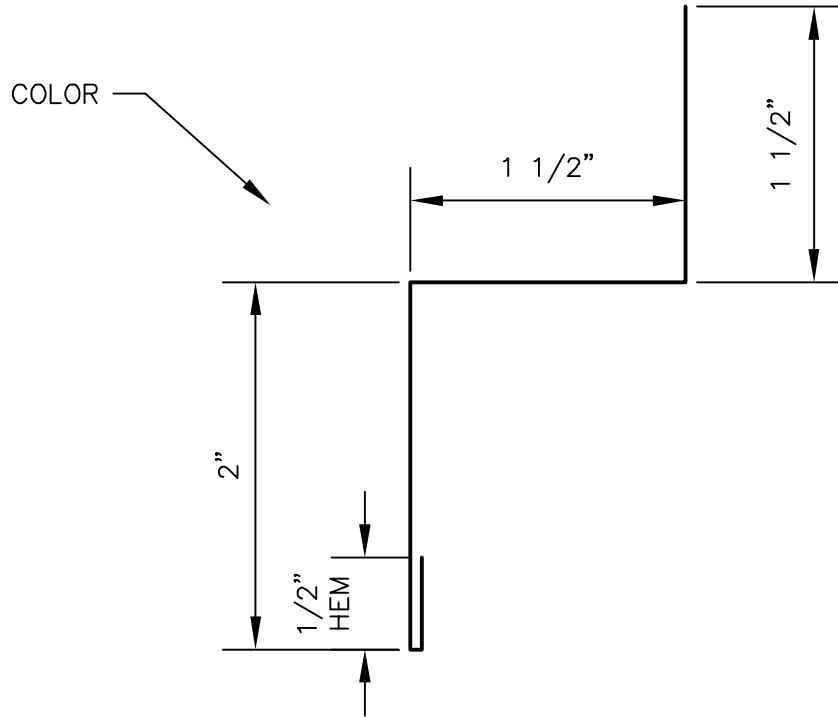

ALTERNATE WAINSCOAT TRIM

PANEL PROFILES	GAUGE
MULTI-RIB	26
MULTI-V	26
R-PANEL	26