

238T INDEX

<u>DWG #:</u>	<u>DESCRIPTION:</u>	<u>IMAGE #:</u>
MT-2	Ridge Cap	700
MT-3	Vented Ridge Cap	701
MT-5	Hip Cap	702
MT-7	Valley Trim (w/ Integral Clip)	703
MT-8	Valley Trim (w/o Clip)	704
MT-9	Transition Trim (w/ Integral Clip)	705
MT-10	Valley Trim	706
MT-17	238T Zee Closure	718
MT-17N	238T Notched Zee Closure	719
MT-25	High Eave Trim	726
MT-26	Standard Eave Drip Trim	727
MT-28	Alternate Eave Trim	729
MT-29	Alternate Eave Drip Trim	730
MT-31	Standard Rake Trim	732
MT-32	Alternate Rake Trim	733
MT-34	Standard Sidewall Trim	735
MT-35	Standard Headwall Trim	736
MT-36	Curved Rake Trim (2 pc system)	737
MT-37	Standard Cleat	738
MT-38	Standard Offset Cleat	739
MT-61	Standard Box Gutter	758
MT-62	Flanged Box Gutter	759
MT-63B	7" Box Gutter	760
MT-63C	7" Box Gutter (for 138T & 238T Panels)	841
MT-64	Round Face Gutter	761
MT-65	Half Round Gutter	762
MT-67	Gutter / Downspout Strap	763
MT-68	Gutter End Cap (for Standard & Flanged Box Gutter)	764
MT-69B	Gutter End Cap (for 7" Box Gutter)	765
MT-133	Perforated "J" Channel	786
MT-154	Vented Headwall Trim	796
MT-156	Rake Support Cleat	798
MT-157	238T Standard Eave / Rake Offset Flashing	799
MT-183	Rake Trim	830
MT-187	238T Retro Clip Eave Trim	834
MT-189	Floating Ridge Trim	836
MT-190	Floating Ridge Trim for Vented	837

238T INDEX (cont.)

<u>DWG #:</u>	<u>DESCRIPTION:</u>	<u>IMAGE #:</u>
MT-191	Floating Hip Trim	838
MT-192	Floating Headwall Trim	839
MT-238T-CLOS	238T Metal Closure @ Ridge	806
MT-238T-HIP	238T Metal Closure @ Hip	807

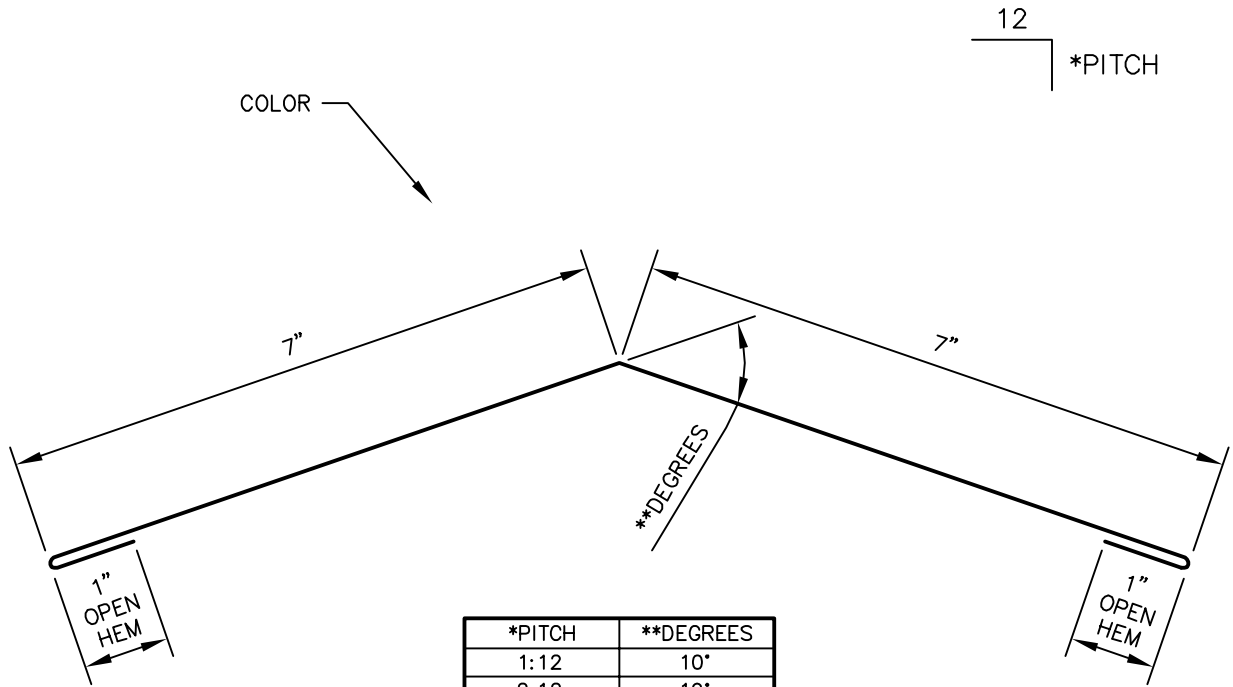

*PITCH	**DEGREES
1:12	10°
2:12	19°
3:12	28°
4:12	37°
5:12	45°
6:12	53°
7:12	61°
8:12	68°
9:12	74°
10:12	80°
11:12	85°
12:12	90°

RIDGE CAP

PANEL PROFILES	GAUGE
138T	24
238T	24
INSTALOC	24
MAXIMA 2"	24
MAXIMA 2" ADV	24
MAXIMA 2" ADV w/o SHOULDERS	24

GIRTH: 16"
BENDS: AS SPECIFIED

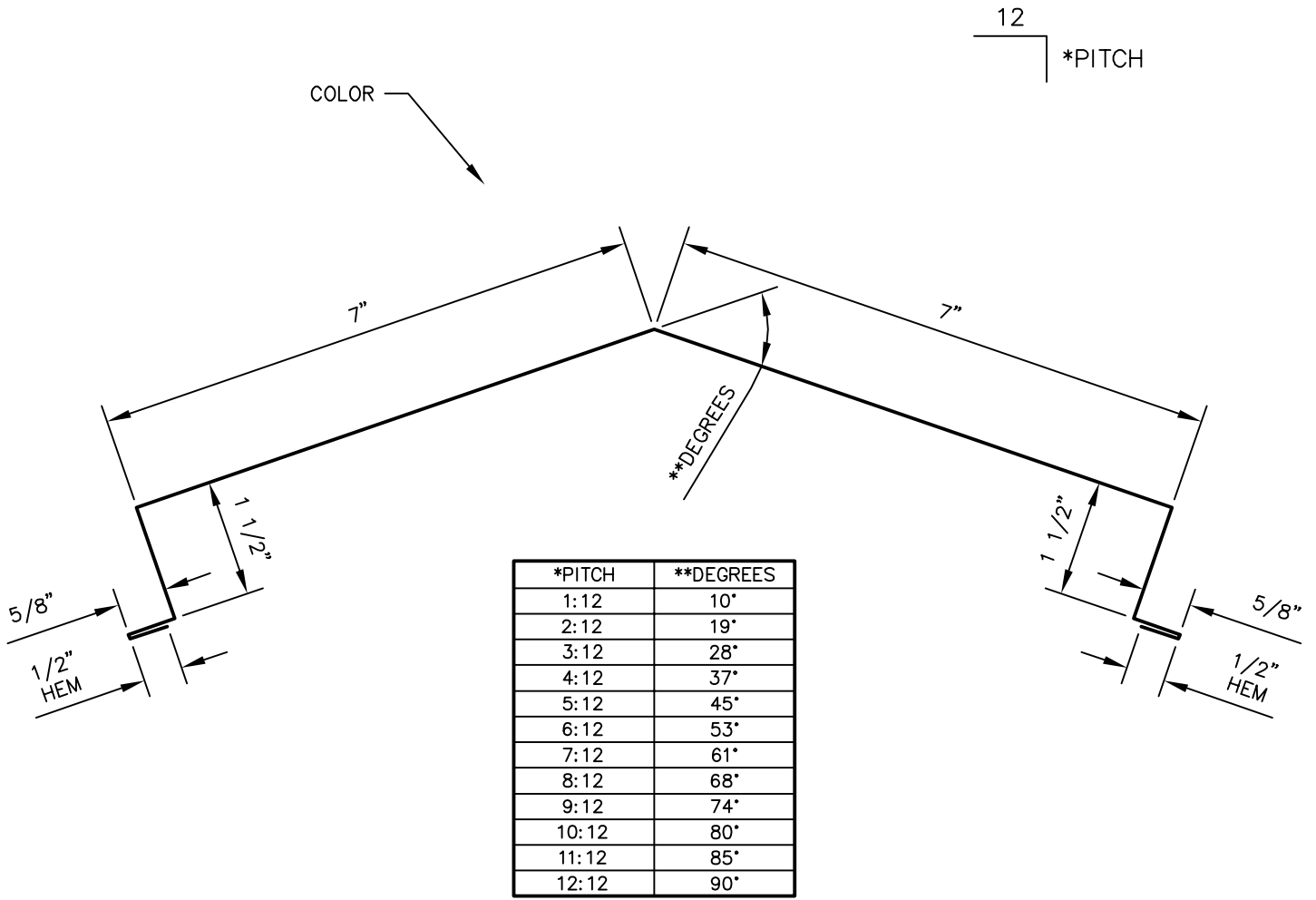

VENTED RIDGE CAP

PANEL PROFILES	GAUGE
138T	24
238T	24
INSTALOC	24
MAXIMA 2"	24
MAXIMA 2" ADV	24
MAXIMA 2" ADV w/o SHOULDERS	24

GIRTH: 19 1/4"
BENDS: 90° AND AS SPECIFIED

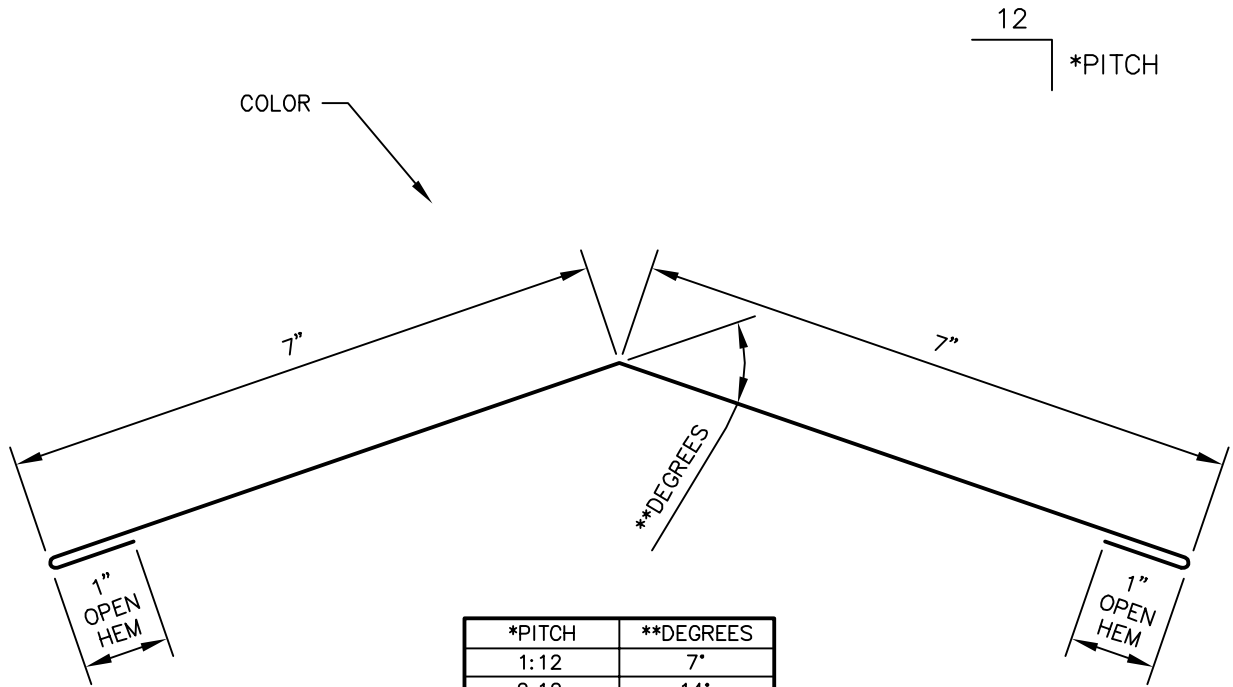

*PITCH	**DEGREES
1:12	7°
2:12	14°
3:12	20°
4:12	27°
5:12	33°
6:12	39°
7:12	45°
8:12	51°
9:12	57°
10:12	63°
11:12	69°
12:12	75°

HIP CAP

PANEL PROFILES	GAUGE
138T	24
238T	24
INSTALOC	24
MAXIMA 2"	24
MAXIMA 2" ADV	24
MAXIMA 2" ADV w/o SHOULDERS	24

GIRTH: 16"
BENDS: AS SPECIFIED



*PITCH	**DEGREES
1:12	48°
2:12	52°
3:12	55°
4:12	58°
5:12	61°
6:12	64°
7:12	68°
8:12	70°
9:12	73°
10:12	76°
11:12	79°
12:12	82°

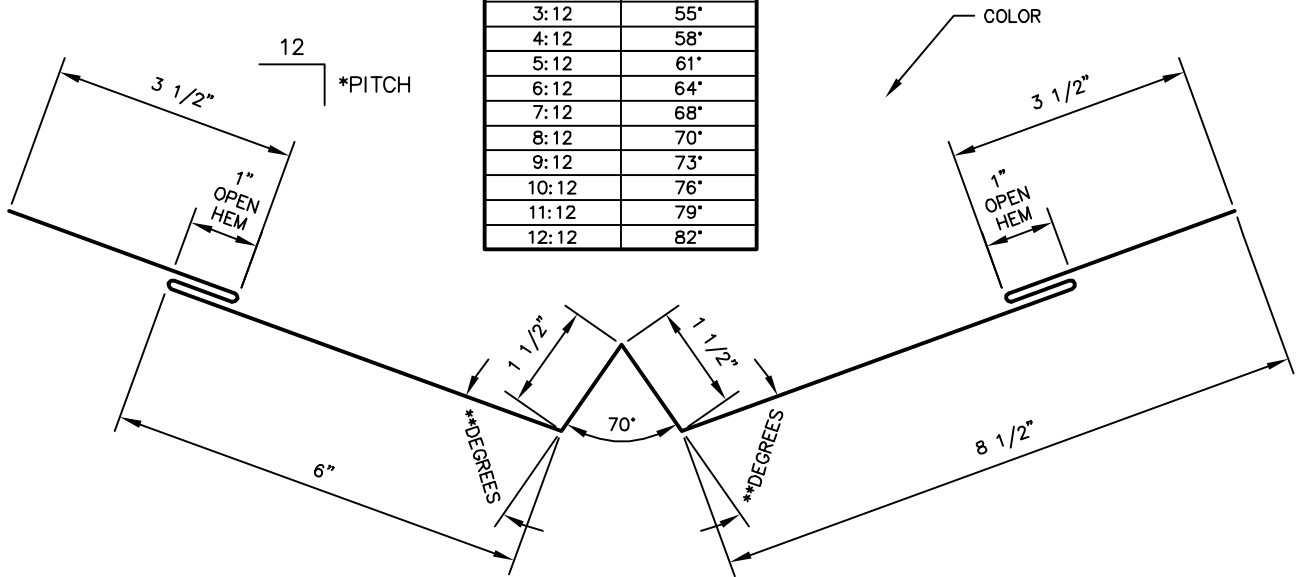

VALLEY TRIM
(w/ INTEGRAL CLEAT)

PANEL PROFILES	GAUGE
138T	24
238T	24
INSTALOC	24
MAXIMA 2"	24
MAXIMA 2" ADV	24
MAXIMA 2" ADV w/o SHOULDERS	24

GIRTH: 24"
BENDS: AS SPECIFIED



*PITCH	**DEGREES
1:12	48°
2:12	52°
3:12	55°
4:12	58°
5:12	61°
6:12	64°
7:12	68°
8:12	70°
9:12	73°
10:12	76°
11:12	79°
12:12	82°

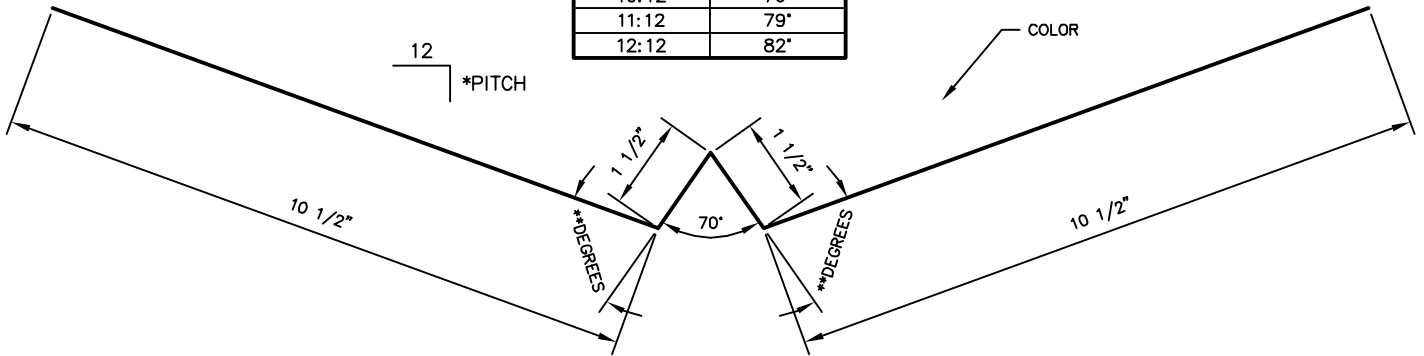

VALLEY TRIM
(w/o CLEAT)

PANEL PROFILES	GAUGE
138T	24
238T	24
INSTALOC	24
MAXIMA 2"	24
MAXIMA 2" ADV	24
MAXIMA 2" ADV w/o SHOULDERS	24

GIRTH: 24"
BENDS: AS SPECIFIED

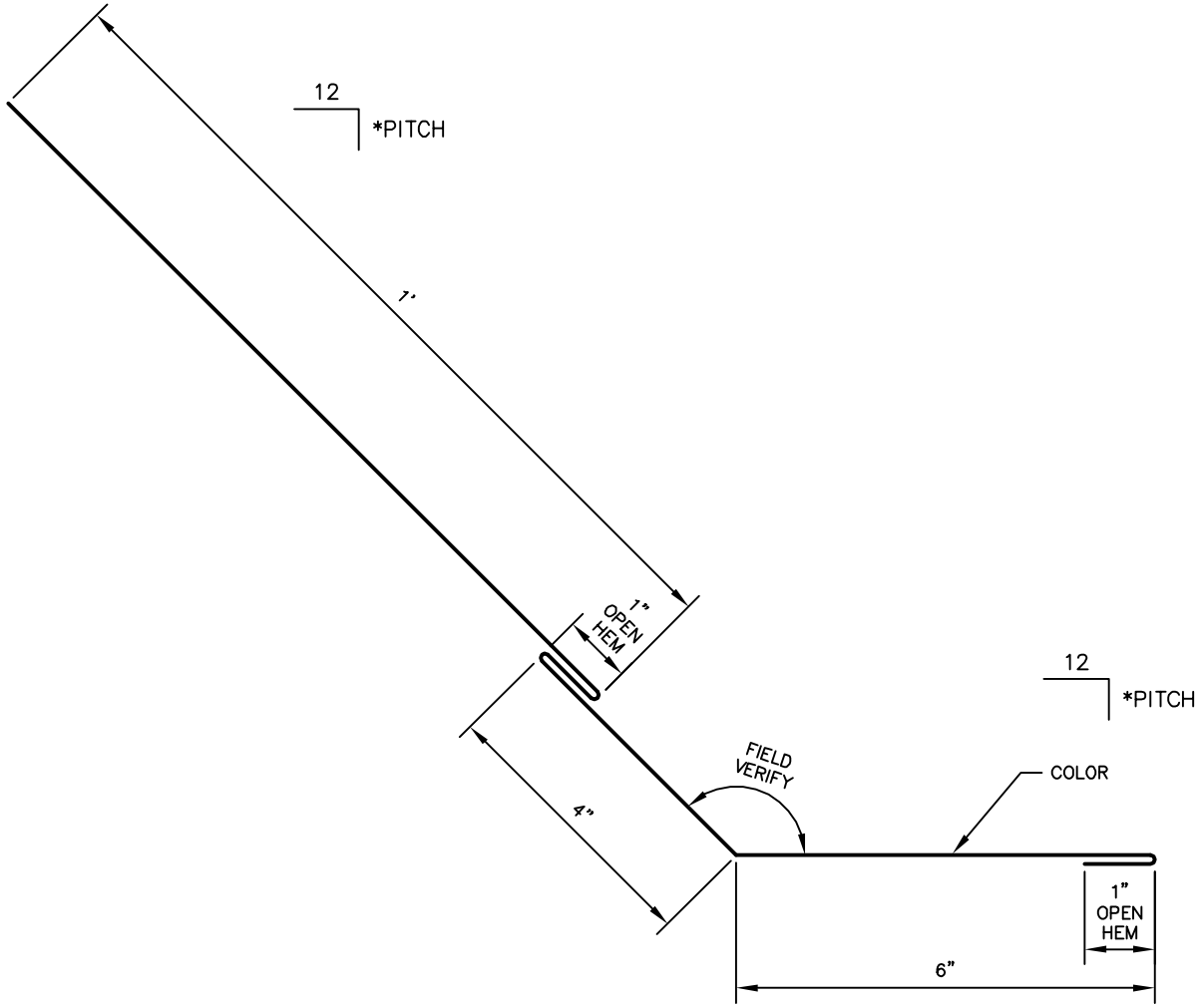

TRANSITION TRIM
(w/ INTEGRAL CLEAT)

PANEL PROFILES	GAUGE
138T	24
238T	24
INSTALOC	24
MAXIMA 2"	24
MAXIMA 2" ADV	24
MAXIMA 2" ADV w/o SHOULDERS	24

GIRTH: 24"
BENDS: AS SPECIFIED



*PITCH	**DEGREES
1:12	48°
2:12	52°
3:12	55°
4:12	58°
5:12	61°
6:12	64°
7:12	68°
8:12	70°
9:12	73°
10:12	76°
11:12	79°
12:12	82°

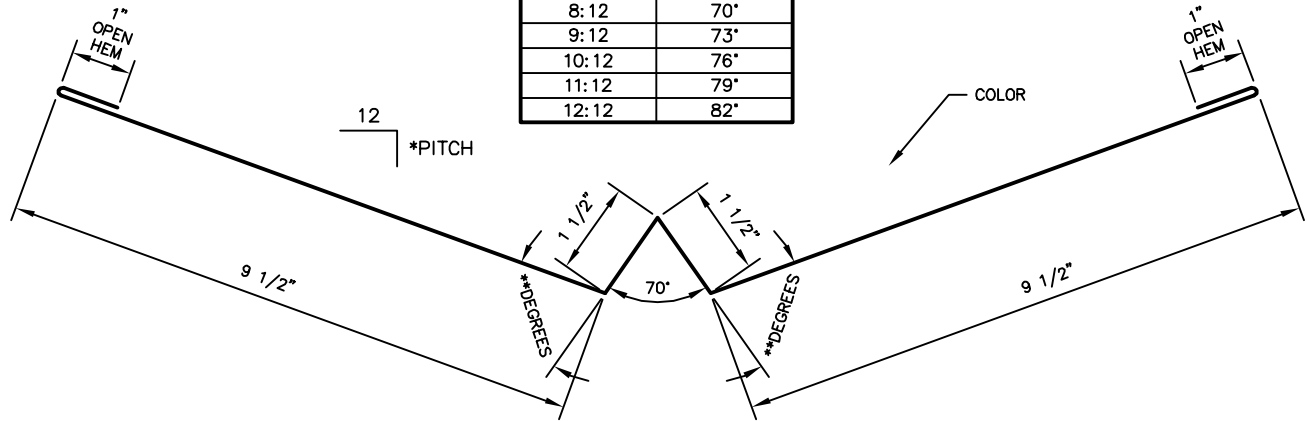

*USE WITH (2) MT-11 VALLEY CLIPS

VALLEY TRIM

PANEL PROFILES	GAUGE
138T	24
238T	24
INSTALOC	24
MAXIMA 2"	24
MAXIMA 2" ADV	24
MAXIMA 2" ADV w/o SHOULDERS	24

GIRTH: 24"
BENDS: AS SPECIFIED

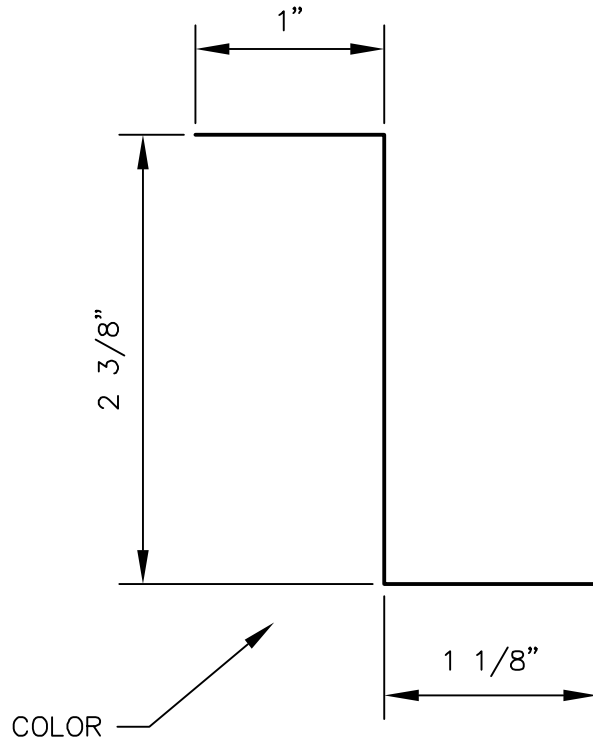

238T ZEE CLOSURE

PANEL PROFILES	GAUGE
238T	24

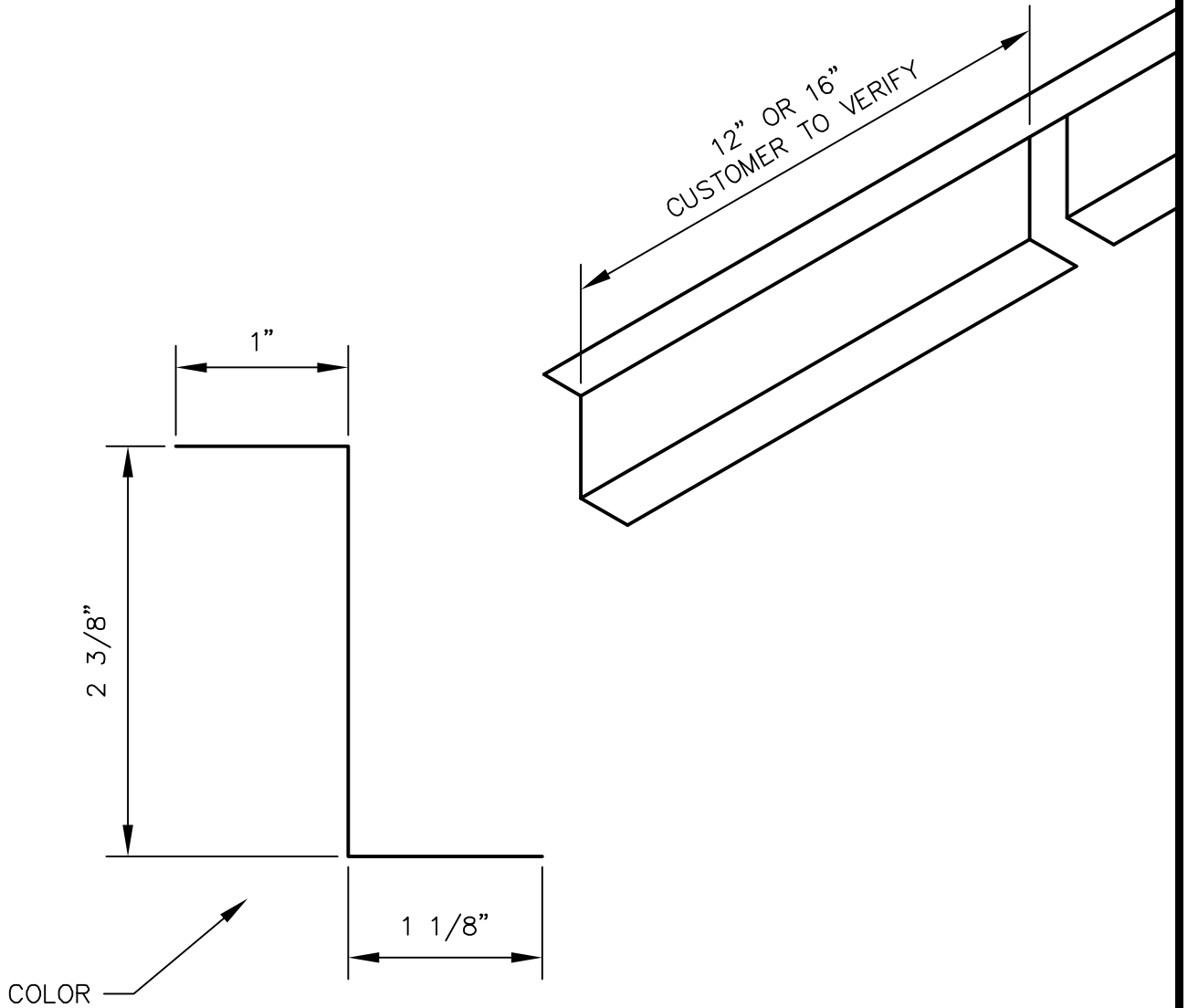

238T NOTCHED ZEE CLOSURE

PANEL PROFILES	GAUGE
238T	24

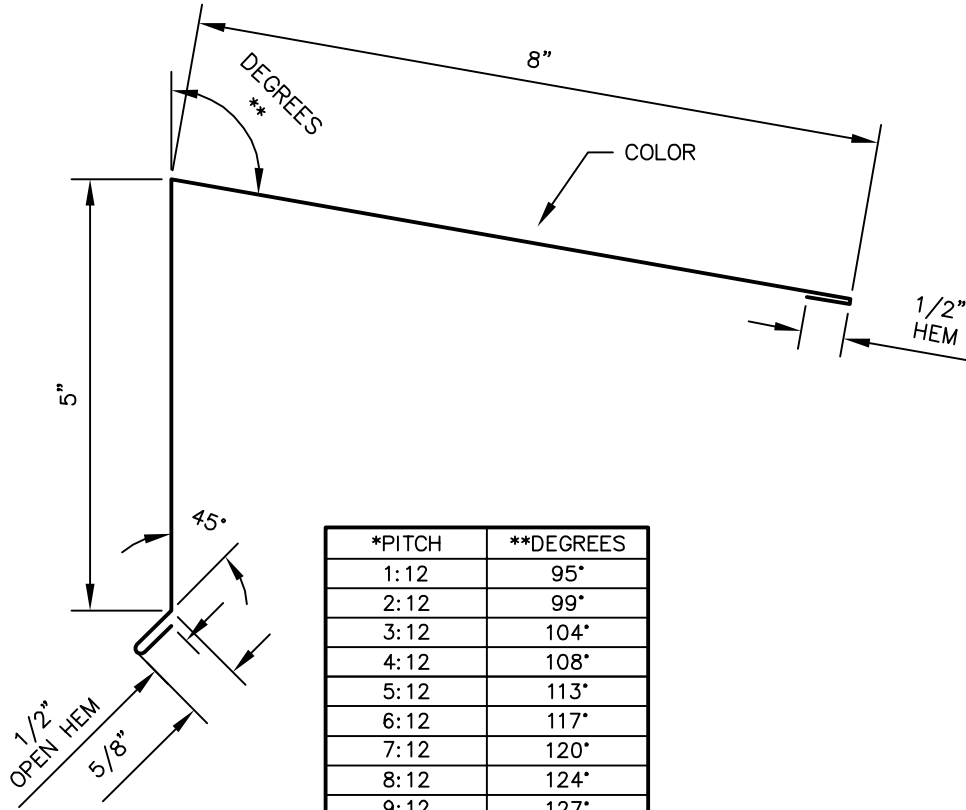
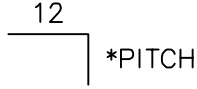

*PITCH	**DEGREES
1:12	95°
2:12	99°
3:12	104°
4:12	108°
5:12	113°
6:12	117°
7:12	120°
8:12	124°
9:12	127°
10:12	130°
11:12	133°
12:12	135°

HIGH EAVE TRIM

PANEL PROFILES	GAUGE
138T	24
238T	24
INSTALOC	24
MAXIMA 2"	24
MAXIMA 2" ADV	24
MAXIMA 2" ADV w/o SHOULDERS	24

GIRTH: 14 5/8"
BENDS: AS SPECIFIED

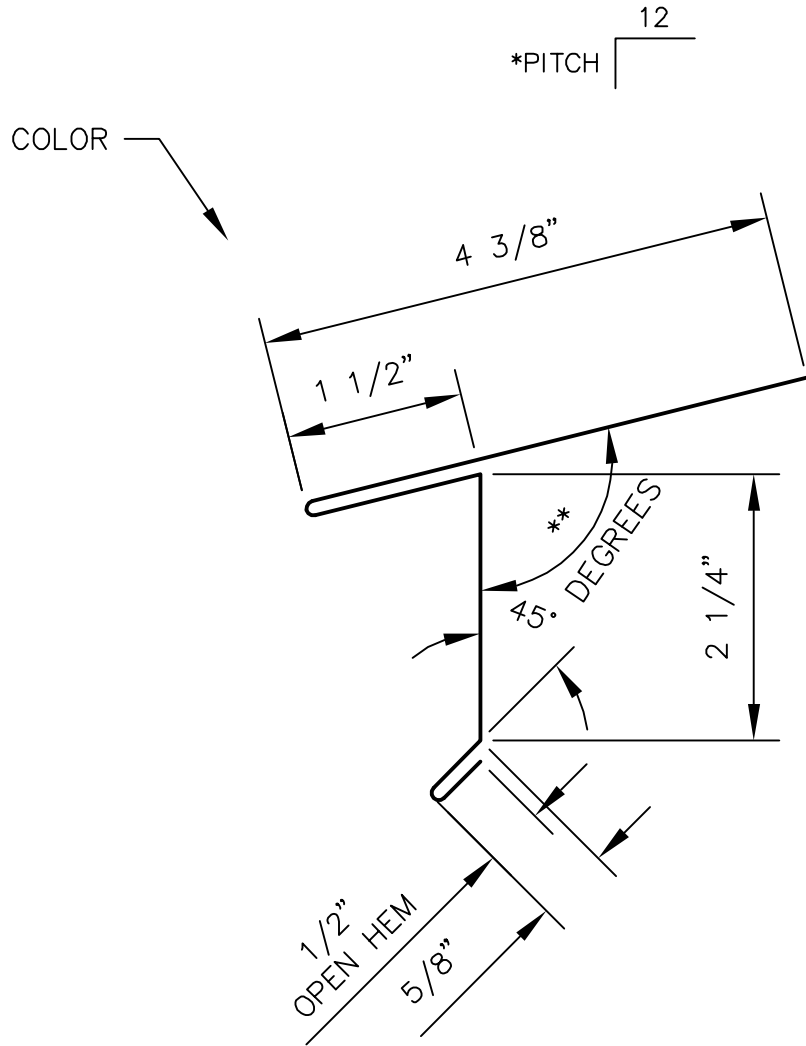

*PITCH	**DEGREES
1:12	95°
2:12	99°
3:12	104°
4:12	108°
5:12	113°
6:12	117°
7:12	120°
8:12	124°
9:12	127°
10:12	130°
11:12	133°
12:12	135°

STANDARD EAVE DRIP TRIM

PANEL PROFILES	GAUGE
138T	24
238T	24
INSTALOC	24
MAXIMA 2"	24
MAXIMA 2" ADV	24
MAXIMA 2" ADV w/o SHOULDERS	24

GIRTH: 9 1/4"
BENDS: AS SPECIFIED



USE WITH MT-38 OFFSET CLEAT

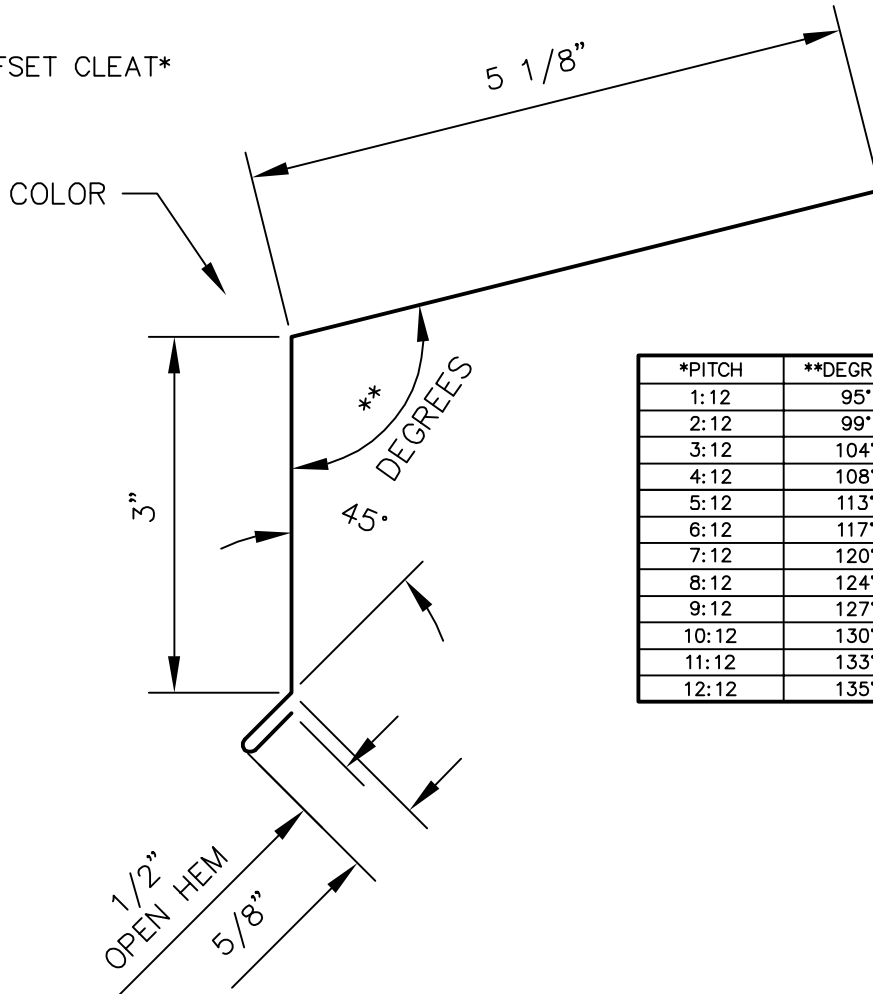

*PITCH	**DEGREES
1:12	95°
2:12	99°
3:12	104°
4:12	108°
5:12	113°
6:12	117°
7:12	120°
8:12	124°
9:12	127°
10:12	130°
11:12	133°
12:12	135°

ALTERNATE EAVE TRIM

PANEL PROFILES	GAUGE
138T	24
238T	24
INSTALOC	24
MAXIMA 2"	24
MAXIMA 2" ADV	24
MAXIMA 2" ADV w/o SHOULDERS	24

GIRTH: 9 1/4"
BENDS: AS SPECIFIED

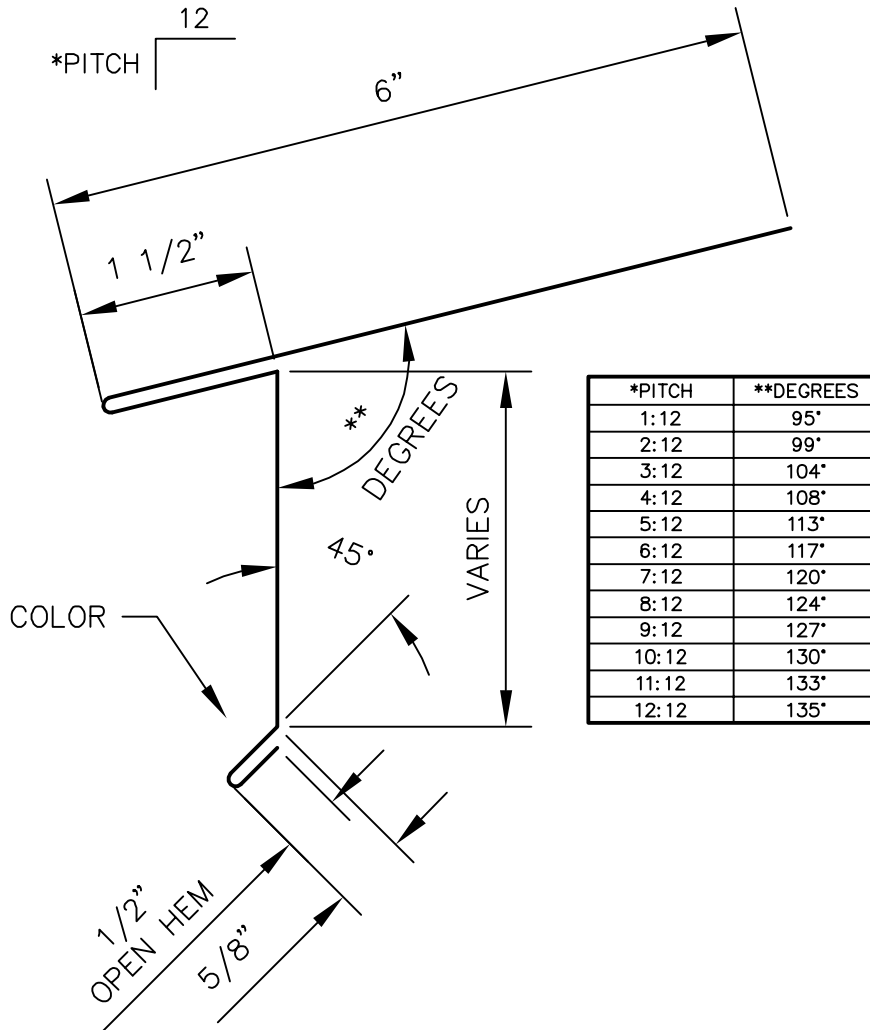

ALTERNATE EAVE DRIP TRIM

PANEL PROFILES	GAUGE
138T	24
238T	24
INSTALOC	24
MAXIMA 2"	24
MAXIMA 2" ADV	24
MAXIMA 2" ADV w/o SHOULDERS	24

GIRTH: VARIES
BENDS: AS SPECIFIED

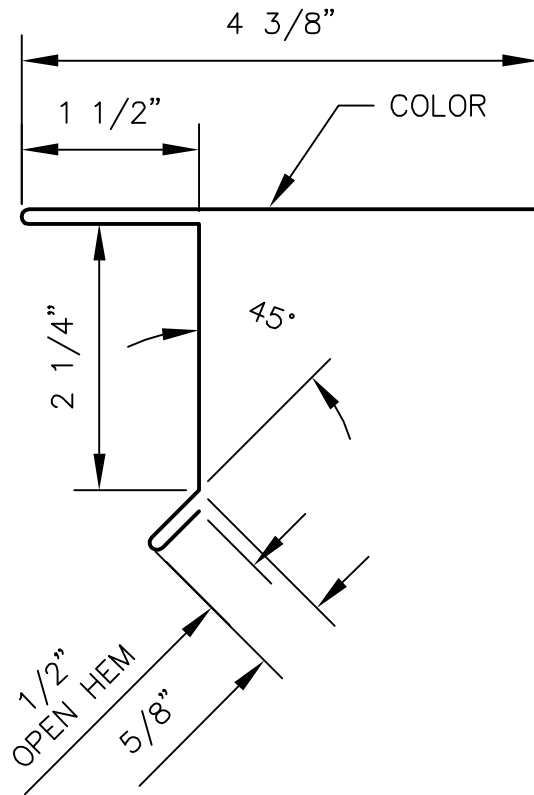

STANDARD RAKE TRIM

PANEL PROFILES	GAUGE
138T	24
238T	24
INSTALOC	24
MAXIMA 2"	24
MAXIMA 2" ADV	24
MAXIMA 2" ADV w/o SHOULDERS	24

GIRTH: 9 1/4"
 BENDS: 90° AND AS SPECIFIED

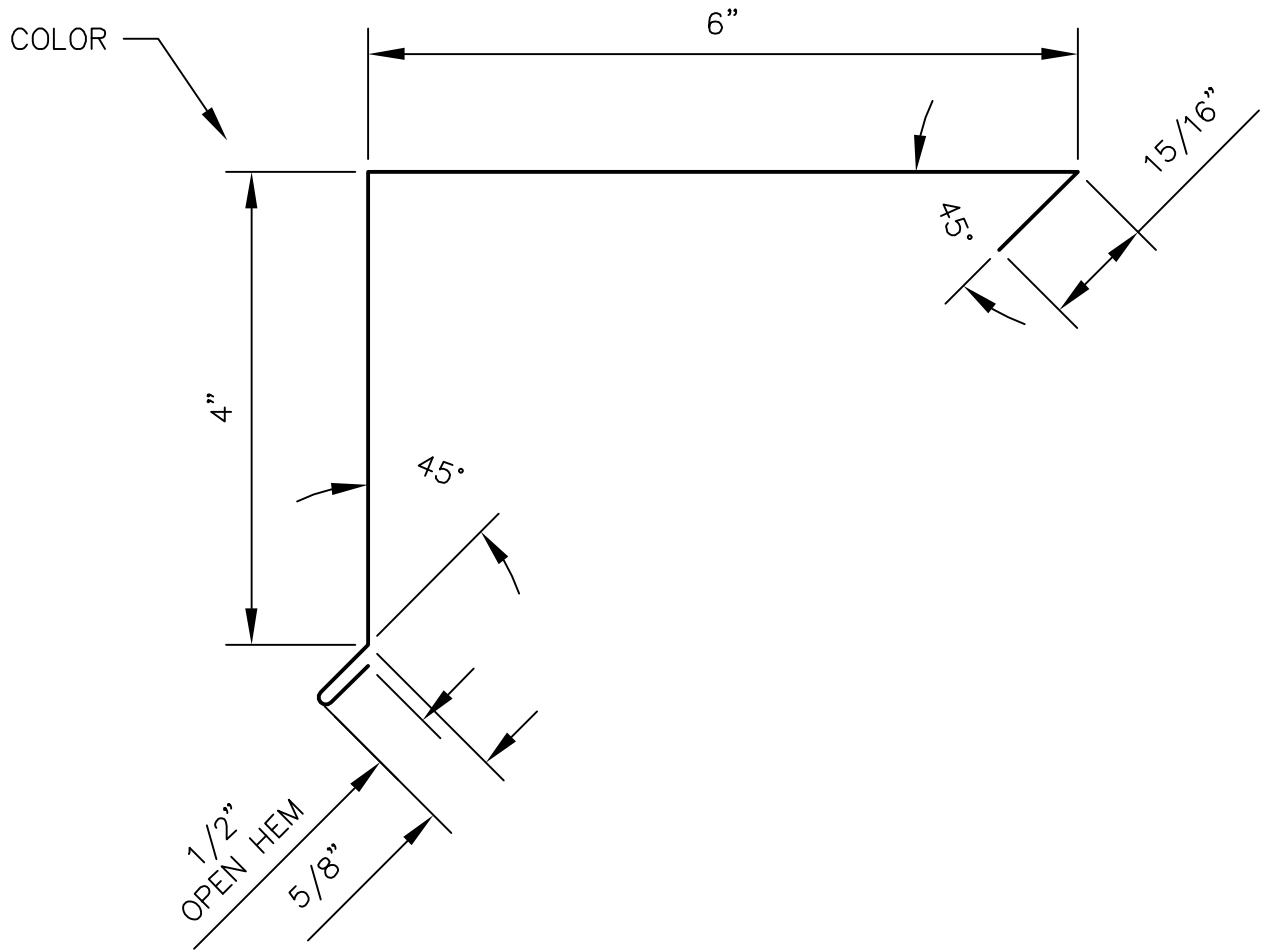

ALTERNATE RAKE TRIM

PANEL PROFILES	GAUGE
138T	24
238T	24
INSTALOC	24
MAXIMA 2"	24
MAXIMA 2" ADV	24
MAXIMA 2" ADV w/o SHOULDERS	24

GIRTH: 12 1/16"
 BENDS: 90° AND AS SPECIFIED

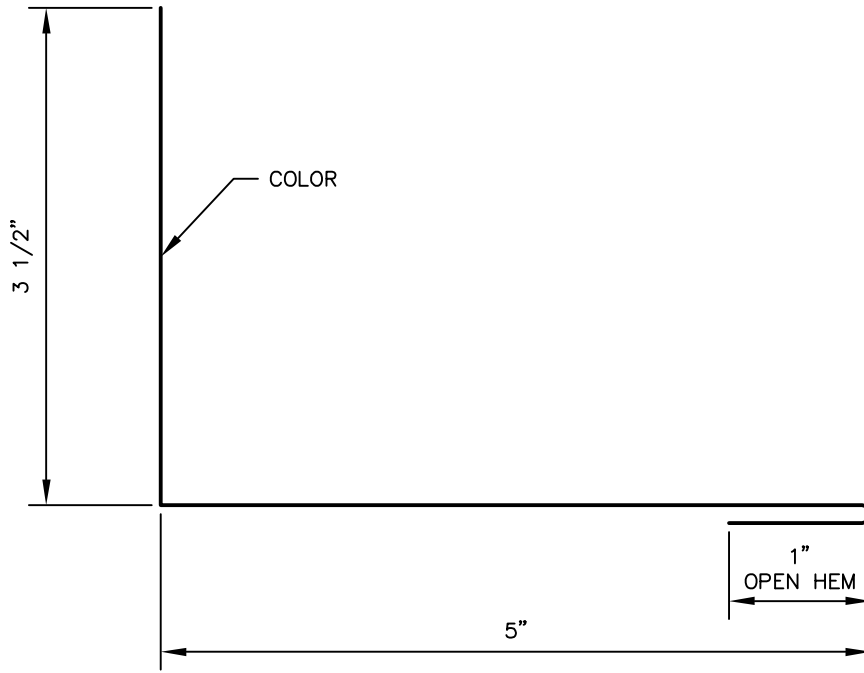

STANDARD SIDEWALL TRIM

PANEL PROFILES	GAUGE
138T	24
238T	24
INSTALOC	24
MAXIMA 2"	24
MAXIMA 2" ADV	24
MAXIMA 2" ADV w/o SHOULDERS	24

GIRTH: 9 1/2"
 BENDS: 90° AND AS SPECIFIED

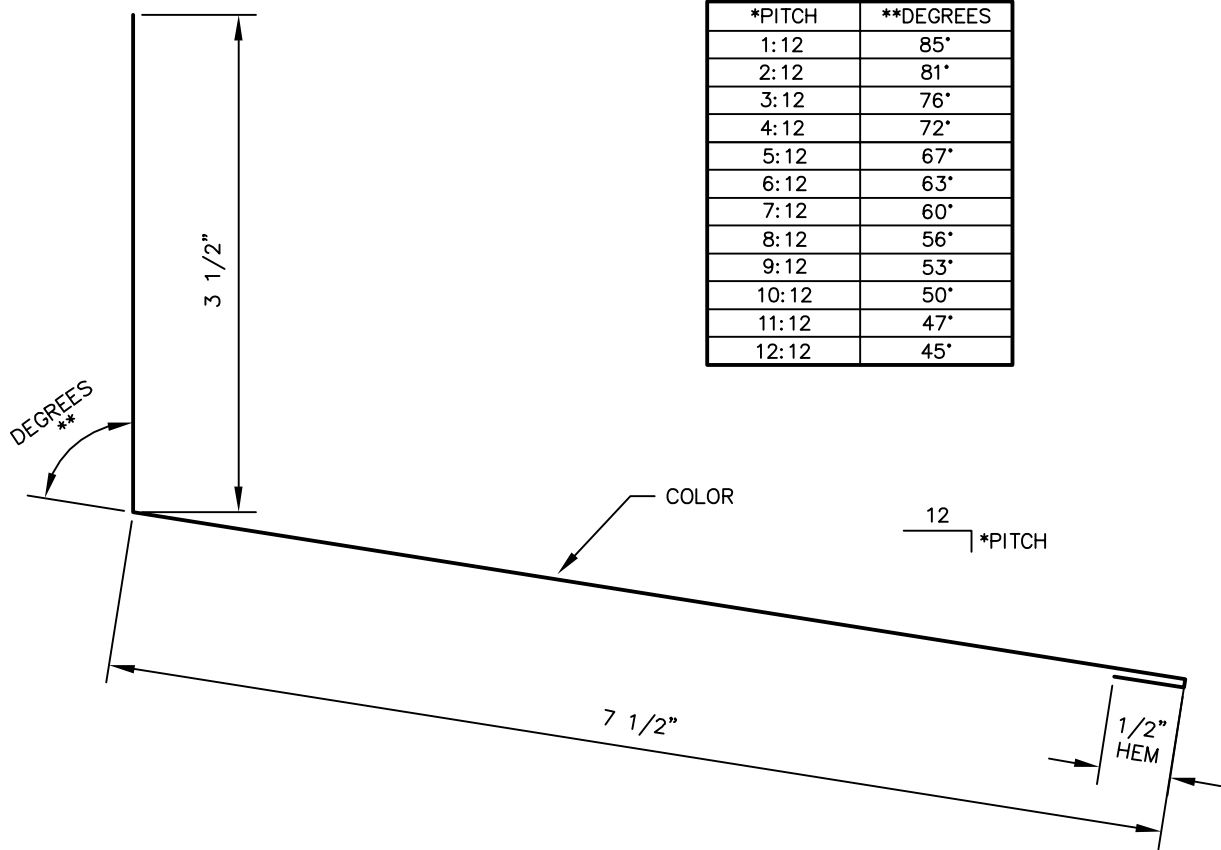

STANDARD HEADWALL TRIM

PANEL PROFILES	GAUGE
138T	24
238T	24
INSTALOC	24
MAXIMA 2"	24
MAXIMA 2" ADV	24
MAXIMA 2" ADV w/o SHOULDERS	24

GIRTH: 11 1/2"
 BENDS: 90° AND AS SPECIFIED

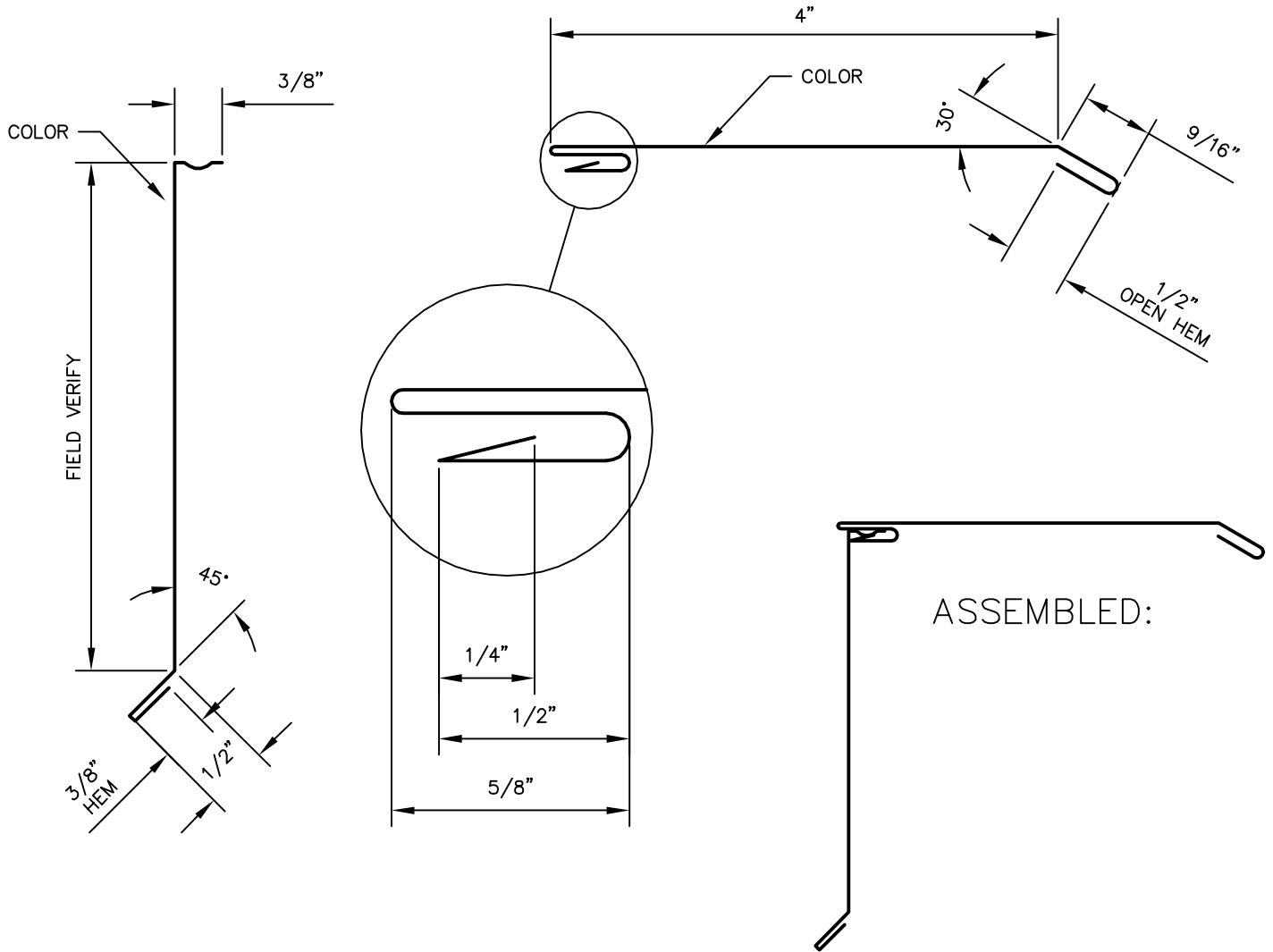

CURVED RAKE TRIM
(2 PIECE SYSTEM)

PANEL PROFILES	GAUGE
138T	24
238T	24
MAXIMA 2" ADV	24
MAXIMA 2" ADV w/o SHOULDERS	24

GIRTH: VARIES
BENDS: 90° AND AS SPECIFIED

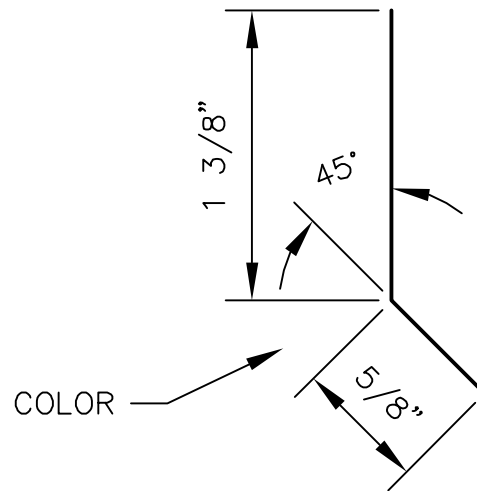

STANDARD CLEAT

PANEL PROFILES	GAUGE
138T	24
238T	24
INSTALOC	24
MAXIMA 2"	24
MAXIMA 2" ADV	24
MAXIMA 2" ADV w/o SHOULDERS	24

GIRTH: 2"
BENDS: AS SPECIFIED

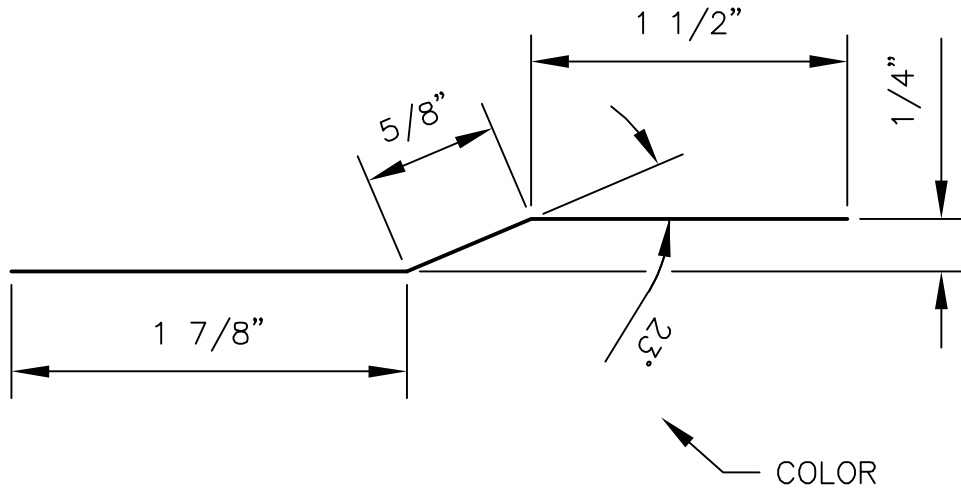

STANDARD OFFSET CLEAT

PANEL PROFILES	GAUGE
138T	24
238T	24
INSTALOC	24

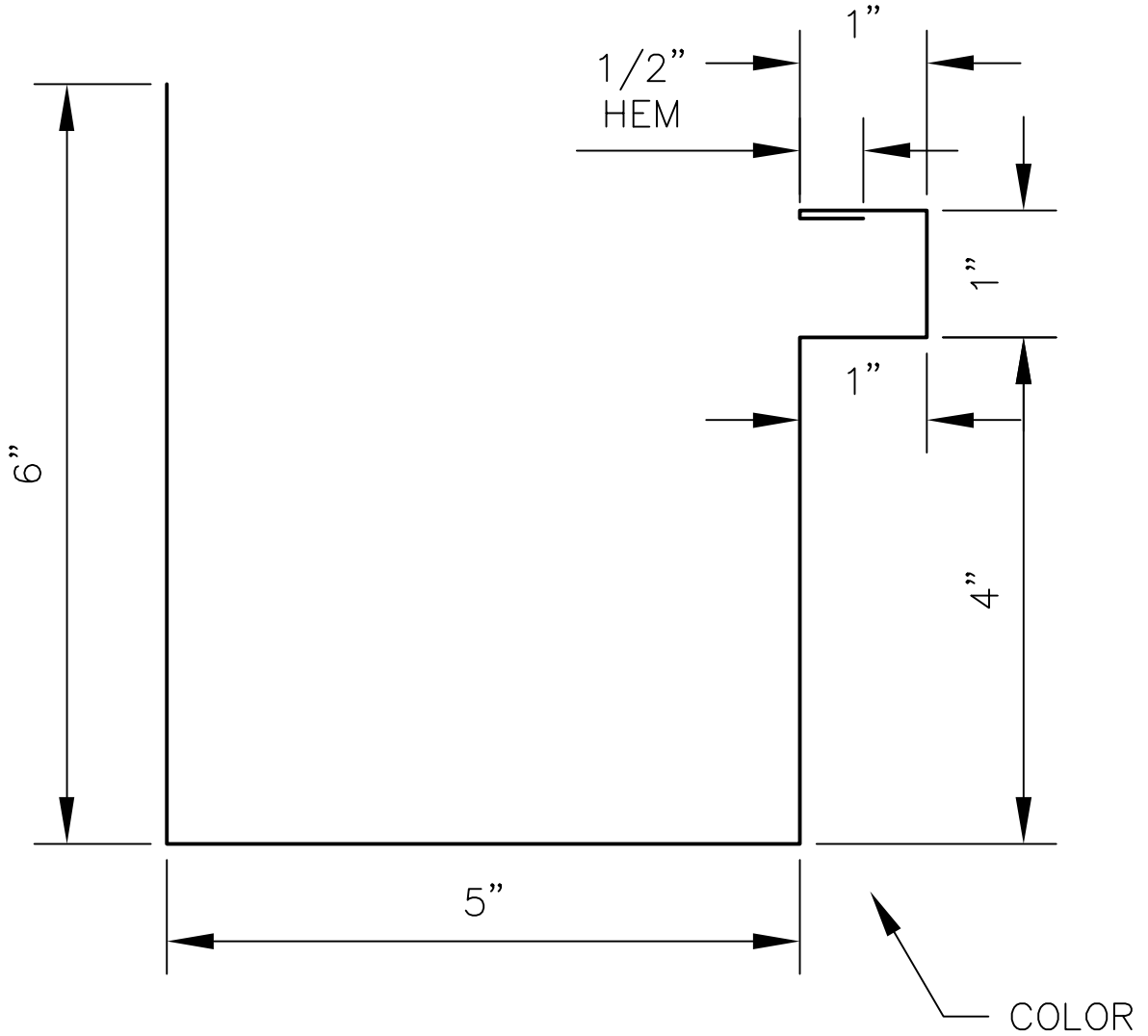

STANDARD BOX GUTTER

PANEL PROFILES	GAUGE
13BT	24
23BT	24
INSTALOC	24
MAXIMA 2"	24
MAXIMA 2" ADV	24
MAXIMA 2" ADV w/o SHOULDERS	24

GIRTH: 18 1/2"
 BENDS: 90° AND AS SPECIFIED

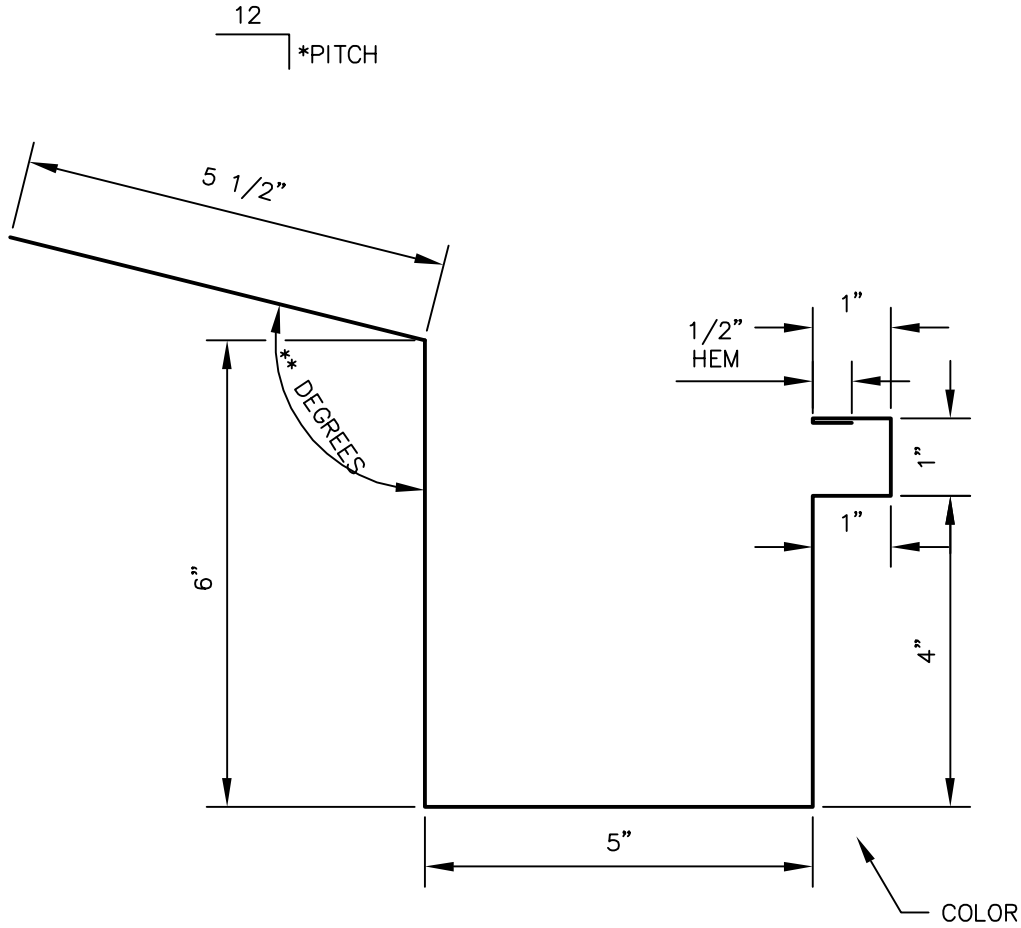

*PITCH	**DEGREES
1:12	95°
2:12	99°
3:12	104°
4:12	108°
5:12	113°
6:12	117°
7:12	120°
8:12	124°
9:12	127°
10:12	130°
11:12	133°
12:12	135°

FLANGED BOX GUTTER

PANEL PROFILES	GAUGE
138T	24
238T	24
INSTALOC	24
MAXIMA 2"	24
MAXIMA 2" ADV	24
MAXIMA 2" ADV w/o SHOULDERS	24

GIRTH: 24"
BENDS: 90° AND AS SPECIFIED

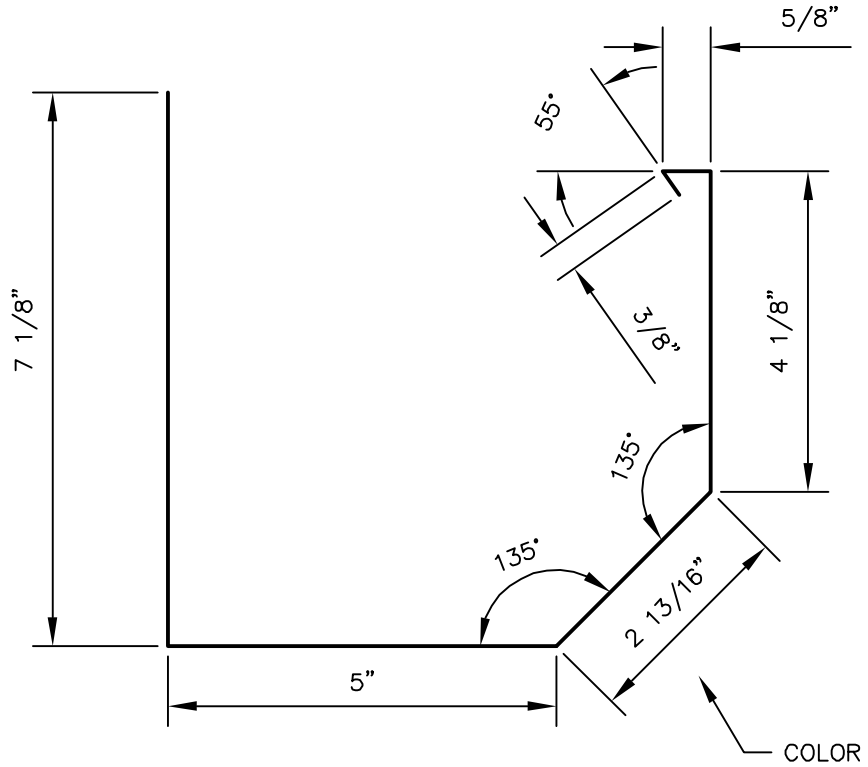

7" BOX GUTTER

PANEL PROFILES	GAUGE
138T	24
238T	24
INSTALOC	24
MAXIMA 2"	24
MAXIMA 2" ADV	24
MAXIMA 2" ADV w/o SHOULDERS	24

GIRTH: 20 1/16"
 BENDS: 90° AND AS SPECIFIED

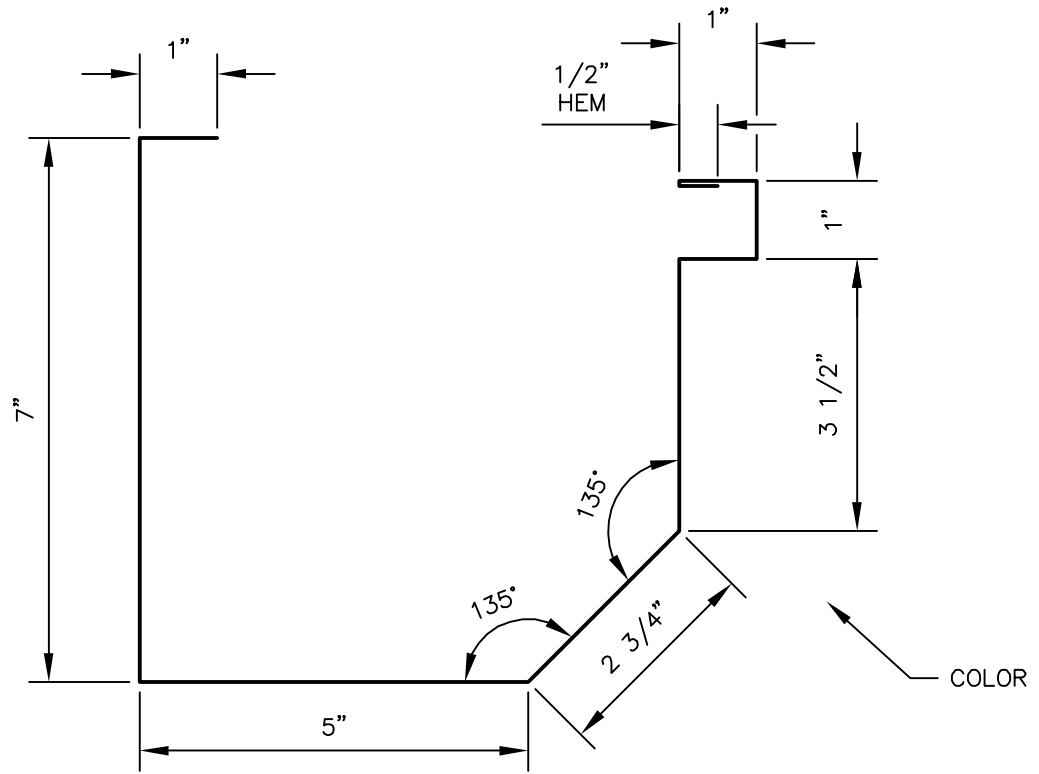

7" BOX GUTTER
(FOR 138T & 238T PANELS)

PANEL PROFILES	GAUGE
138T	24
238T	24

7-18-17 rev.
3-2-17

GIRTH: 22 3/4"
BENDS: 90° AND AS SPECIFIED



*PITCH	**DEGREES
1:12	95°
2:12	99°
3:12	104°
4:12	108°
5:12	113°
6:12	117°
7:12	120°
8:12	124°
9:12	127°
10:12	130°
11:12	133°
12:12	135°

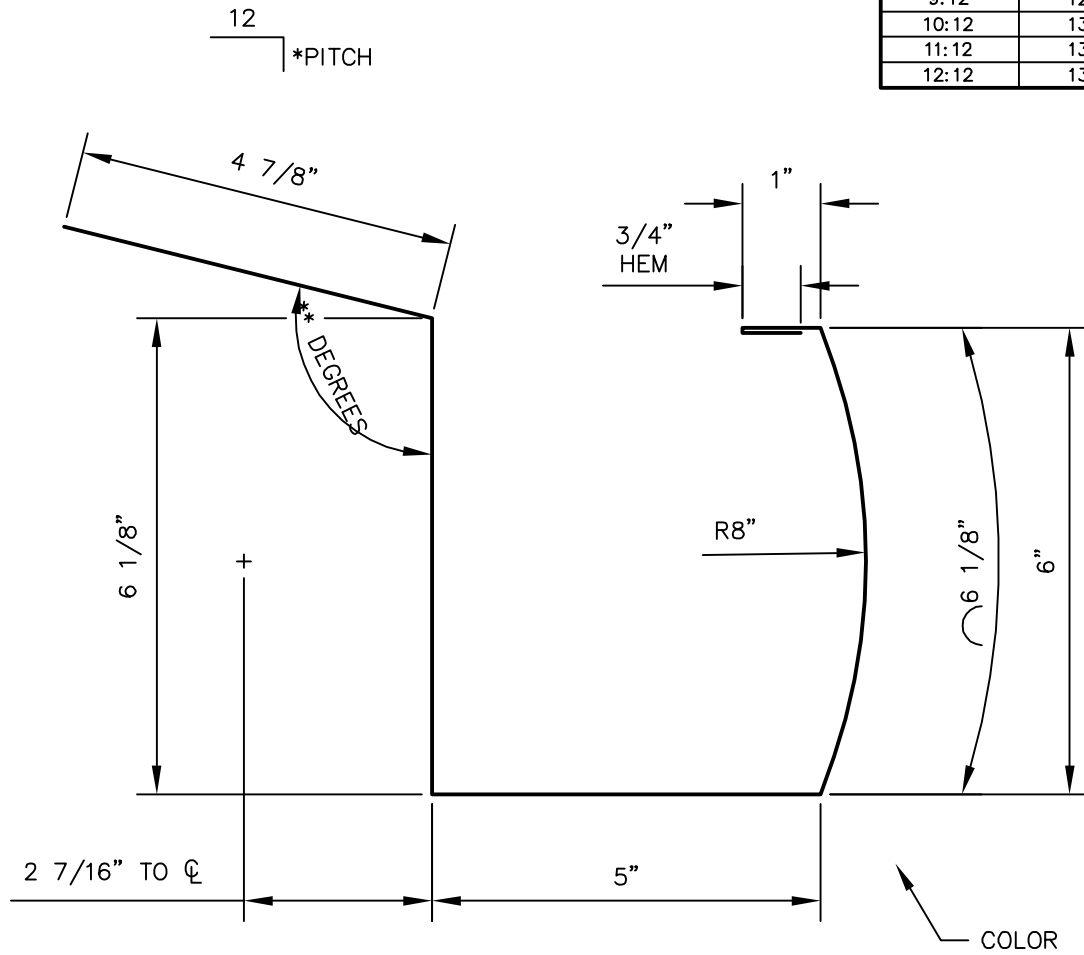

ROUND FACE GUTTER

PANEL PROFILES	GAUGE
138T	24
238T	24
INSTALOC	24
MAXIMA 2"	24
MAXIMA 2" ADV	24
MAXIMA 2" ADV w/o SHOULDERS	24

GIRTH: 24"
BENDS: 90° AND AS SPECIFIED



*PITCH	**DEGREES
1:12	95°
2:12	99°
3:12	104°
4:12	108°
5:12	113°
6:12	117°
7:12	120°
8:12	124°
9:12	127°
10:12	130°
11:12	133°
12:12	135°

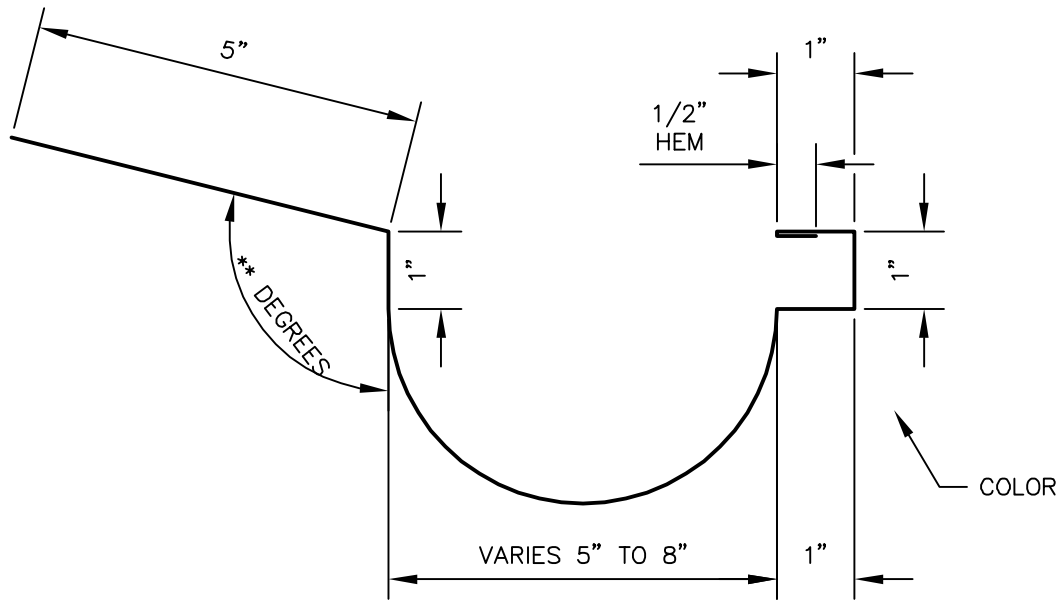
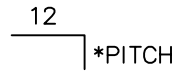

HALF ROUND GUTTER

PANEL PROFILES	GAUGE
138T	24
238T	24
INSTALOC	24
MAXIMA 2"	24
MAXIMA 2" ADV	24
MAXIMA 2" ADV w/o SHOULDERS	24

GIRTH: VARIES
BENDS: 90° AND AS SPECIFIED

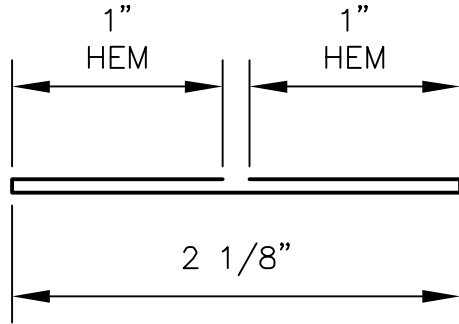

← COLOR

GUTTER/DOWNSPOUT STRAP

PANEL PROFILES	GAUGE
138T	24
238T	24
INSTALOC	24
MAXIMA 2"	24
MAXIMA 2" ADV	24
MAXIMA 2" ADV w/o SHOULDERS	24

GIRTH: 4 1/8" X 10"
BENDS: AS SPECIFIED

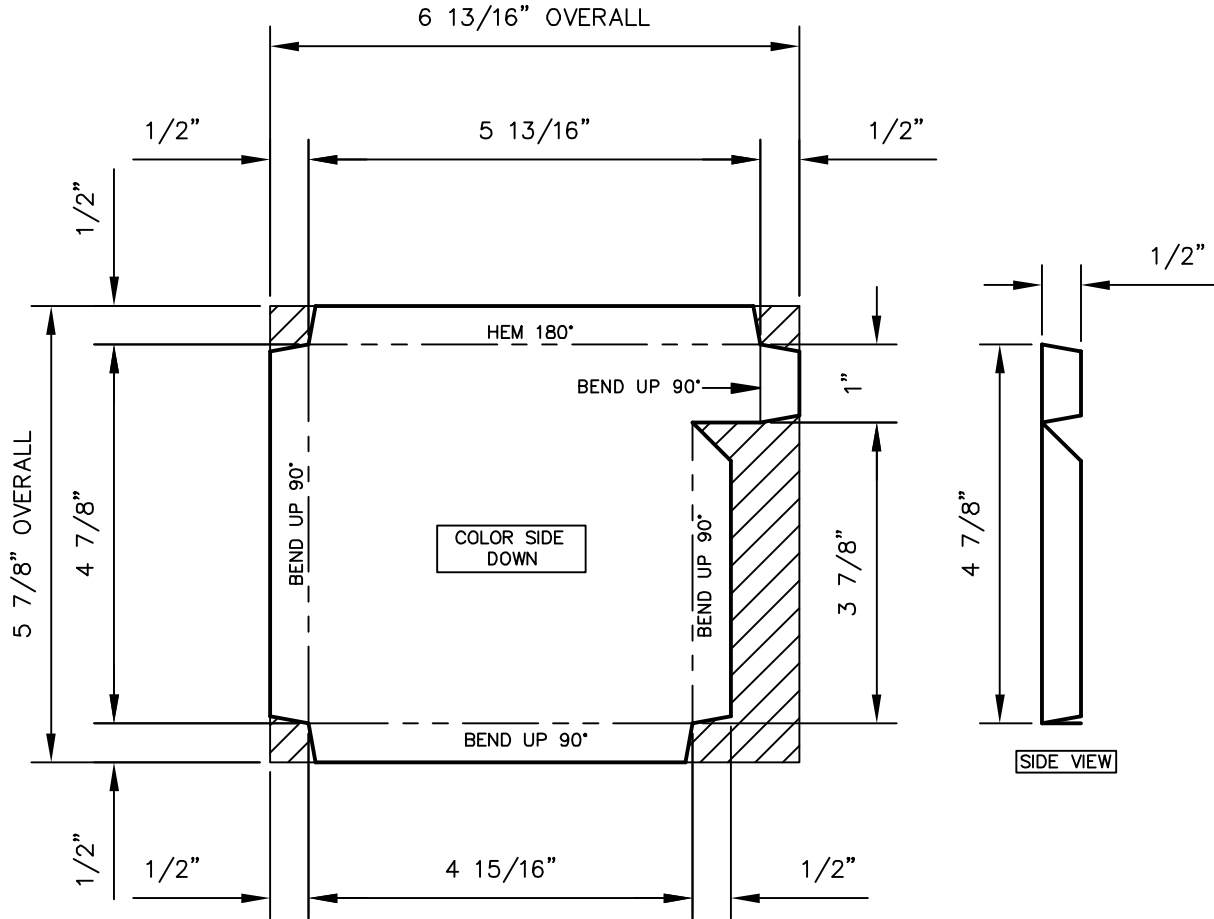

MT-68R= RIGHT END CAP
 MT-68L= LEFT END CAP

GUTTER END CAP

(FITS STANDARD BOX GUTTER & FLANGED BOX GUTTER)

(LEFT HAND SHOWN)

(RIGHT HAND OPP.)

PANEL PROFILES	GAUGE
138T	24
238T	24
INSTALOC	24
MAXIMA 2"	24
MAXIMA 2" ADV	24
MAXIMA 2" ADV w/o SHOULDERS	24

GIRTH: 6 13/16" X 5 7/8"
 BENDS: 90° AND AS SPECIFIED

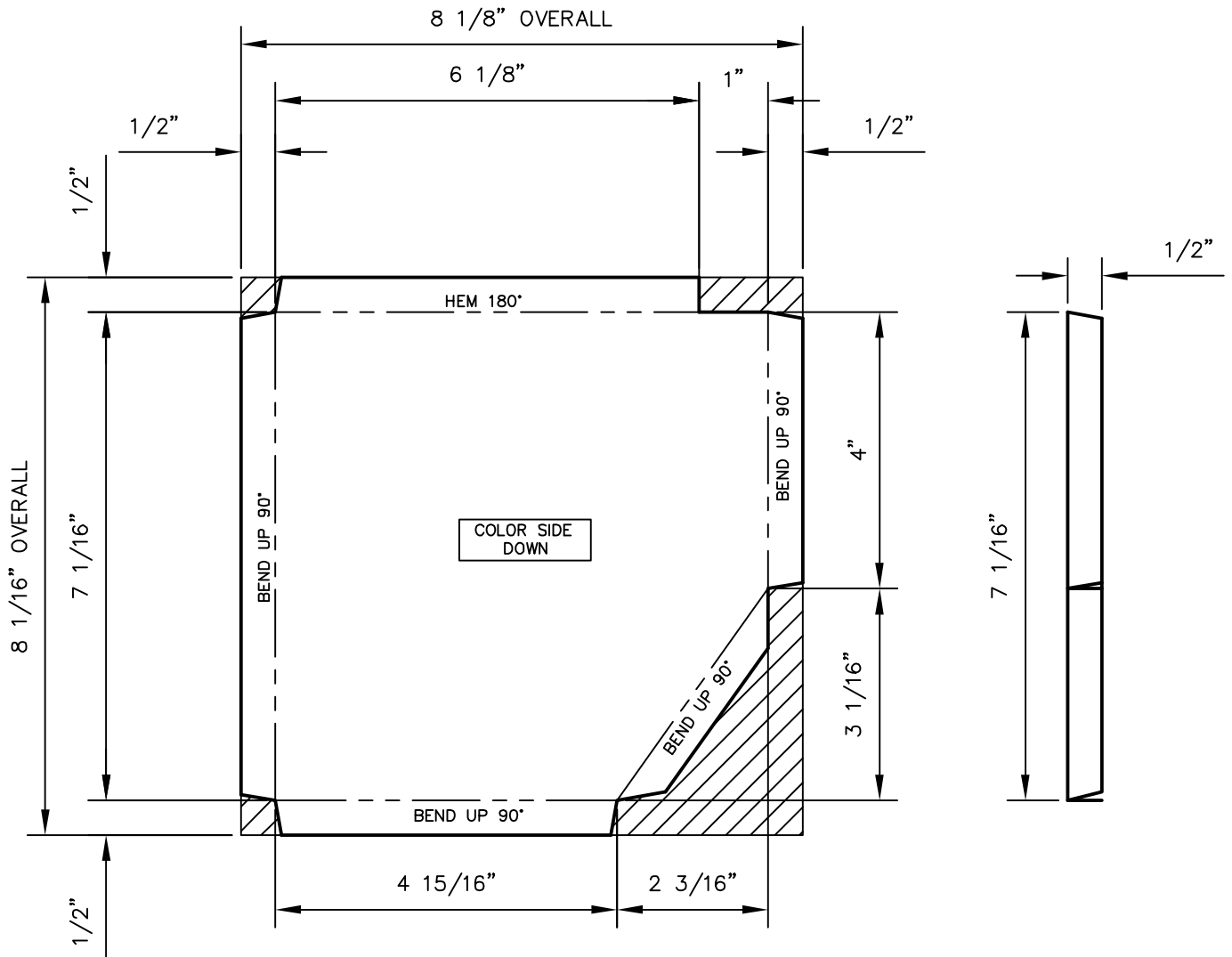

MT-69R= RIGHT END CAP
 MT-69L= LEFT END CAP

GUTTER END CAP

(FITS 7" BOX GUTTER)

(LEFT HAND SHOWN)

(RIGHT HAND OPP.)

PANEL PROFILES	GAUGE
138T	24
238T	24
INSTALOC	24
MAXIMA 2"	24
MAXIMA 2" ADV	24
MAXIMA 2" ADV w/o SHOULDERS	24

GIRTH: 8 1/8" X 8 1/16"
 BENDS: 90° AND AS SPECIFIED



PERFORATIONS DIFFERENT AT HOUSTON PLANT

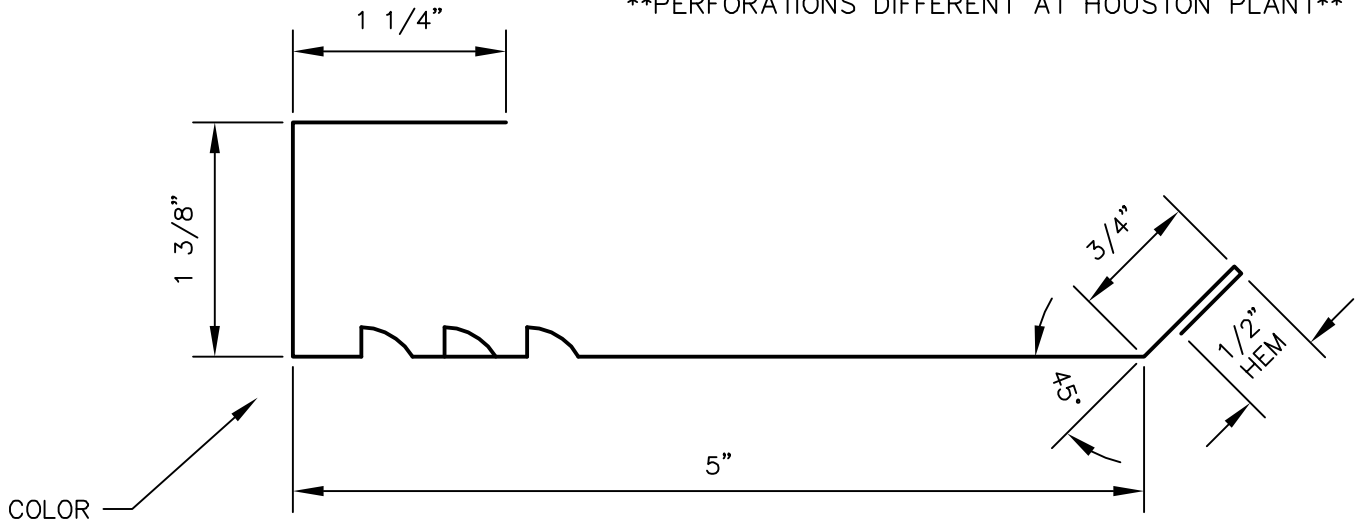

PERFORATED "J" CHANNEL

(USE WITH MT-3 VENTED RIDGE CAP & MT-154 VENTED HEADWALL)

PANEL PROFILES	GAUGE
138T	24
238T	24
INSTALOC	24
MAXIMA 2"	24
MAXIMA 2" ADV	24
MAXIMA 2" ADV w/o SHOULDERS	24

GIRTH: 8 7/8"
BENDS: 90° AND AS SPECIFIED



*PITCH	**DEGREES
1:12	85°
2:12	81°
3:12	76°
4:12	72°
5:12	67°
6:12	63°
7:12	60°
8:12	56°
9:12	53°
10:12	50°
11:12	47°
12:12	45°

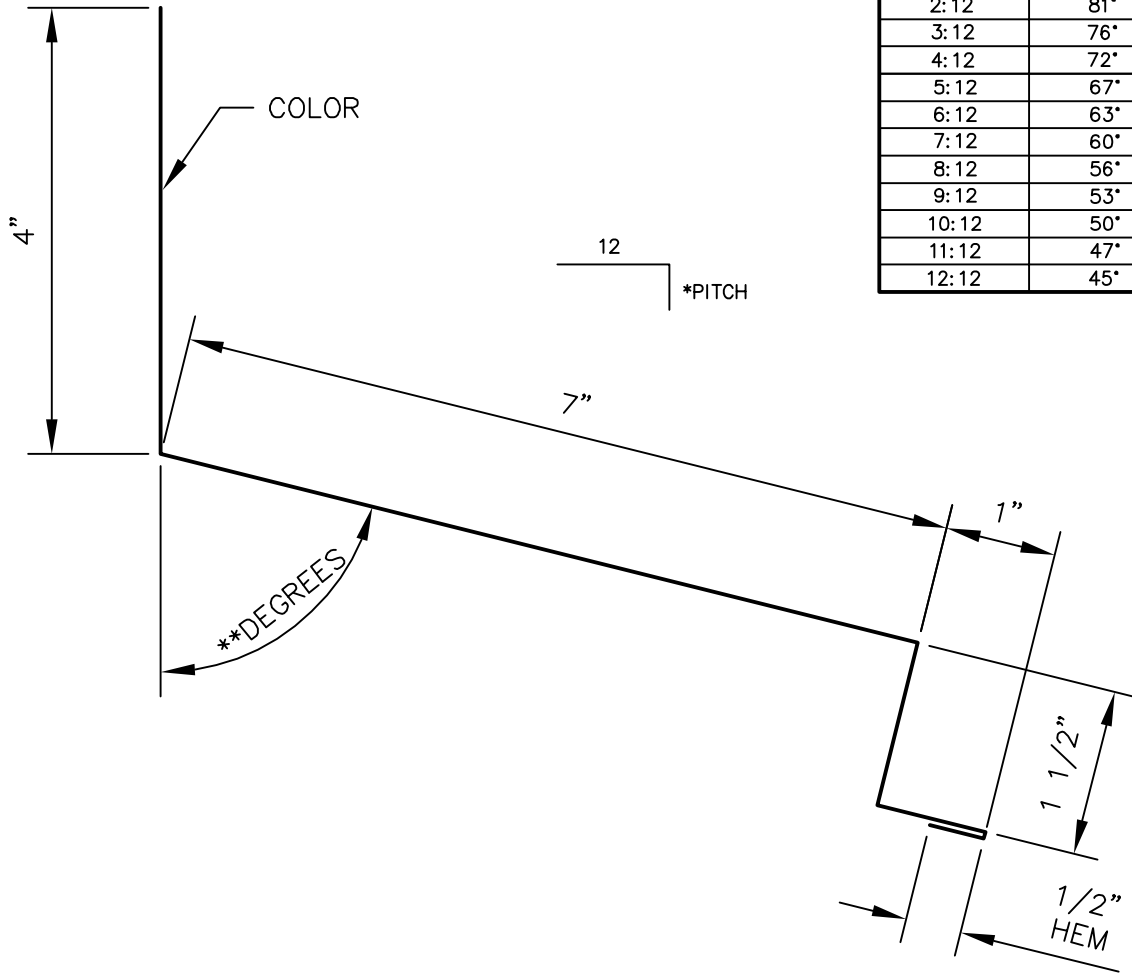

VENTED HEADWALL TRIM
 (USE WITH MT-133 PERFORATED "J" CHANNEL)

PANEL PROFILES	GAUGE
138T	24
238T	24
INSTALOC	24
MAXIMA 2"	24
MAXIMA 2" ADV	24
MAXIMA 2" ADV w/o SHOULDERS	24

GIRTH: 14"
 BENDS: 90° AND AS SPECIFIED

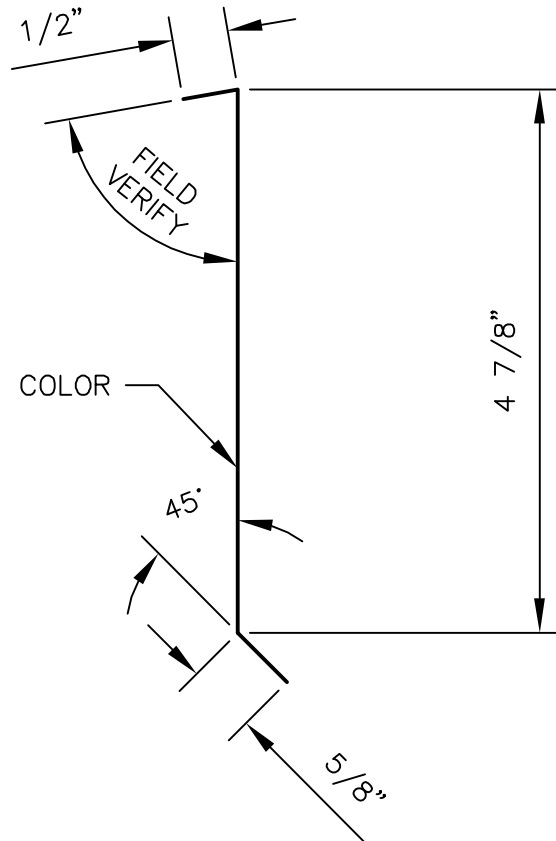

RAKE SUPPORT CLEAT

PANEL PROFILES	GAUGE
138T	24
238T	24
INSTALOC	24
MAXIMA 2"	24
MAXIMA 2" ADV	24
MAXIMA 2" ADV w/o SHOULDERS	24

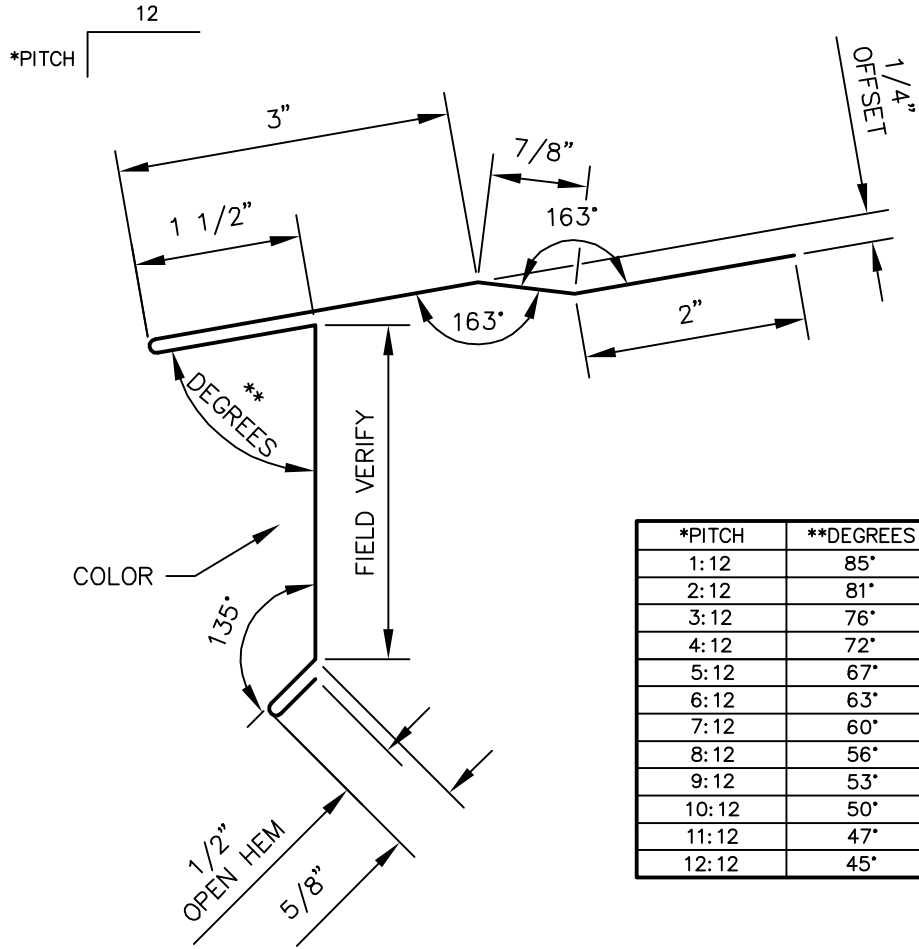

*PITCH	**DEGREES
1:12	85°
2:12	81°
3:12	76°
4:12	72°
5:12	67°
6:12	63°
7:12	60°
8:12	56°
9:12	53°
10:12	50°
11:12	47°
12:12	45°

238T STANDARD EAVE/RAKE OFFSET FLASHING

PANEL PROFILES	GAUGE
238T	24

GIRTH: VARIES
BENDS: AS SPECIFIED

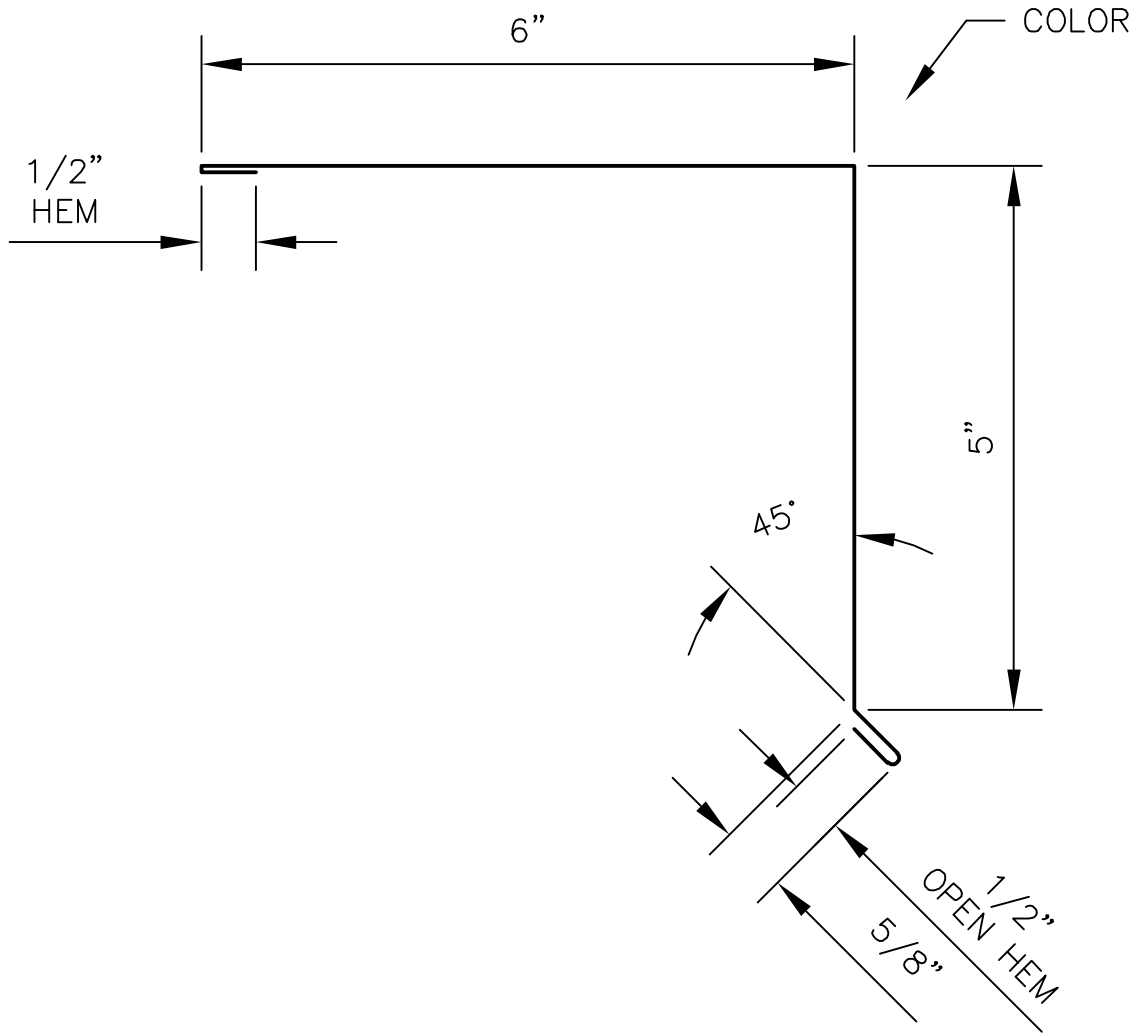

RAKE TRIM

PANEL PROFILES	GAUGE
138T	24
238T	24

7-17-18 rev.
1-19-17

GIRTH: 12 5/8"
BENDS: 90° AND AS SPECIFIED

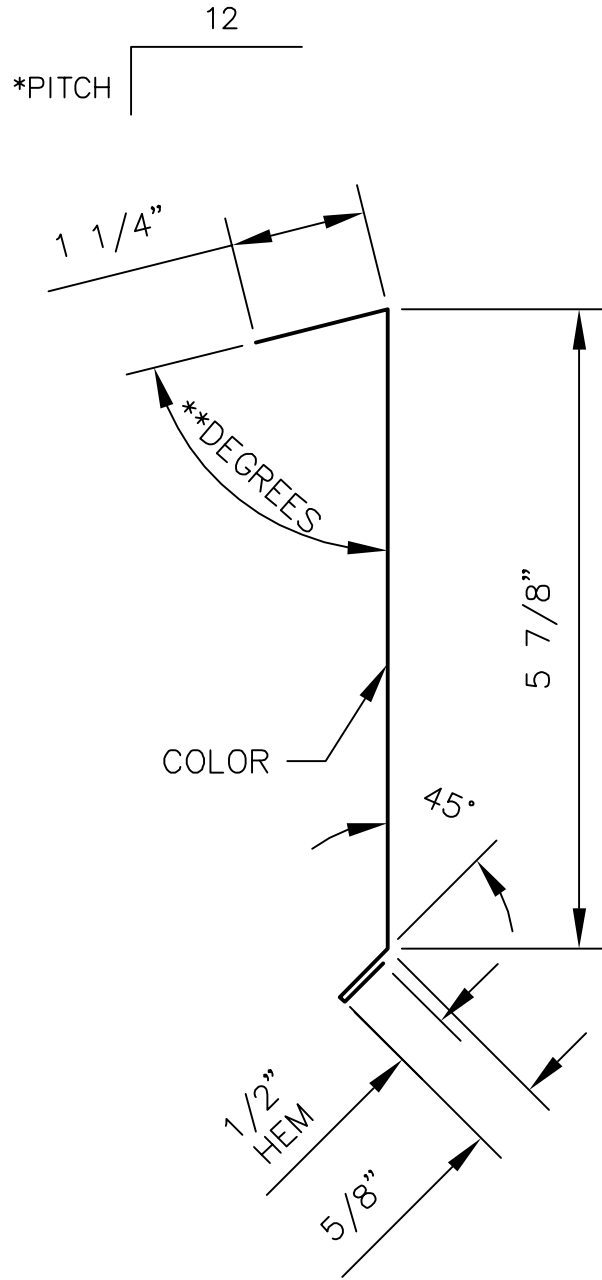

*PITCH	**DEGREES
1:12	85°
2:12	81°
3:12	76°
4:12	72°
5:12	67°
6:12	63°
7:12	60°
8:12	56°
9:12	53°
10:12	50°
11:12	47°
12:12	45°

238T RETRO CLIP EAVE TRIM

PANEL PROFILES	GAUGE
238T	24

GIRTH: 8 1/4"
BENDS: AS SPECIFIED

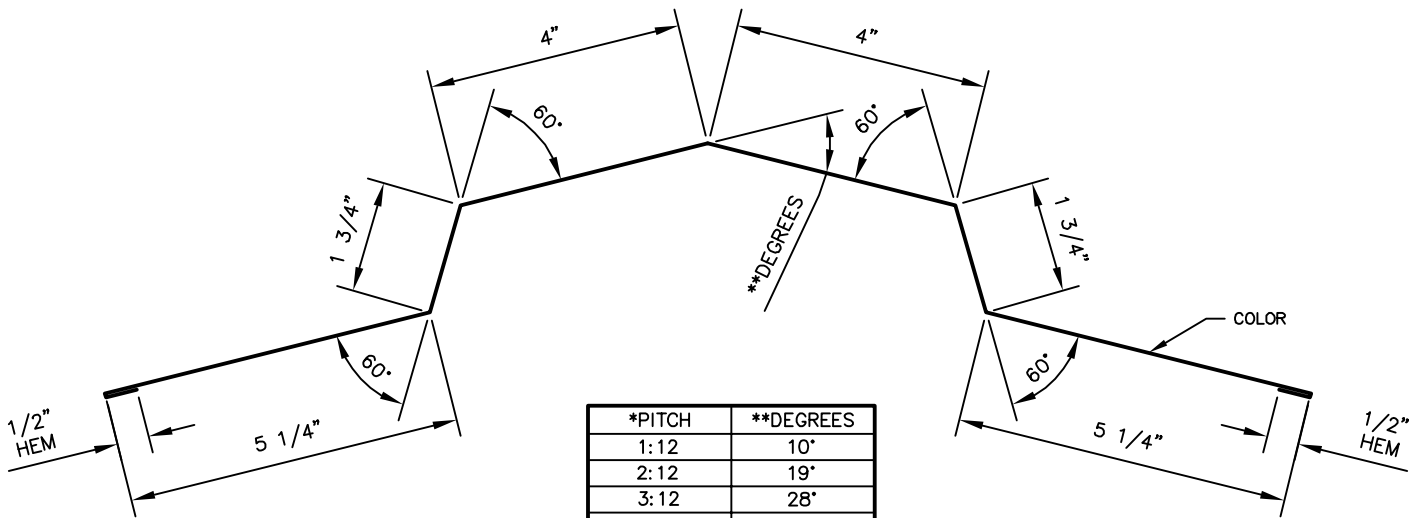
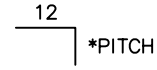

*PITCH	**DEGREES
1:12	10°
2:12	19°
3:12	28°
4:12	37°
5:12	45°
6:12	53°
7:12	61°
8:12	68°
9:12	74°
10:12	80°
11:12	85°
12:12	90°

FLOATING RIDGE TRIM

PANEL PROFILES	GAUGE
138T	24
238T	24
MAXIMA 2"	24
MAXIMA 2" ADV	24
MAXIMA 2" ADV w/o SHOULDERS	24

GIRTH: 23"
BENDS: AS SPECIFIED

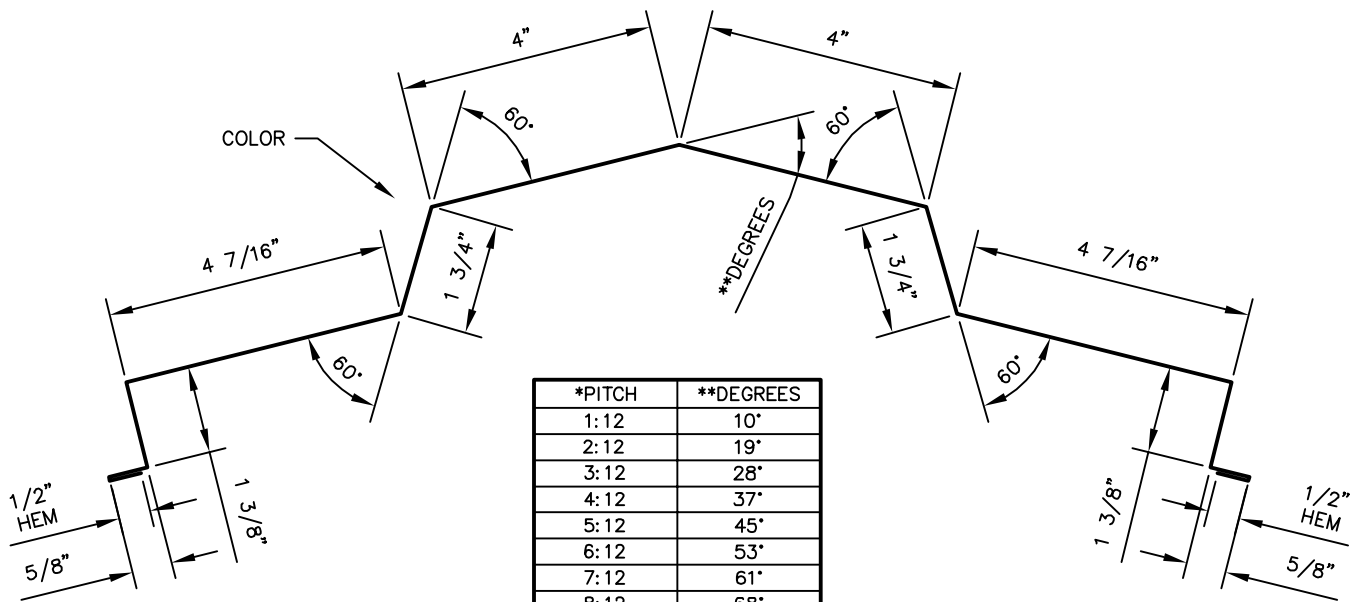
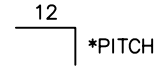

*PITCH	**DEGREES
1:12	10°
2:12	19°
3:12	28°
4:12	37°
5:12	45°
6:12	53°
7:12	61°
8:12	68°
9:12	74°
10:12	80°
11:12	85°
12:12	90°

FLOATING RIDGE TRIM for VENTED

PANEL PROFILES	GAUGE
138T	24
238T	24
MAXIMA 2"	24
MAXIMA 2" ADV	24
MAXIMA 2" ADV w/o SHOULDERS	24

GIRTH: 25 3/8"
 BENDS: 90° AND AS SPECIFIED

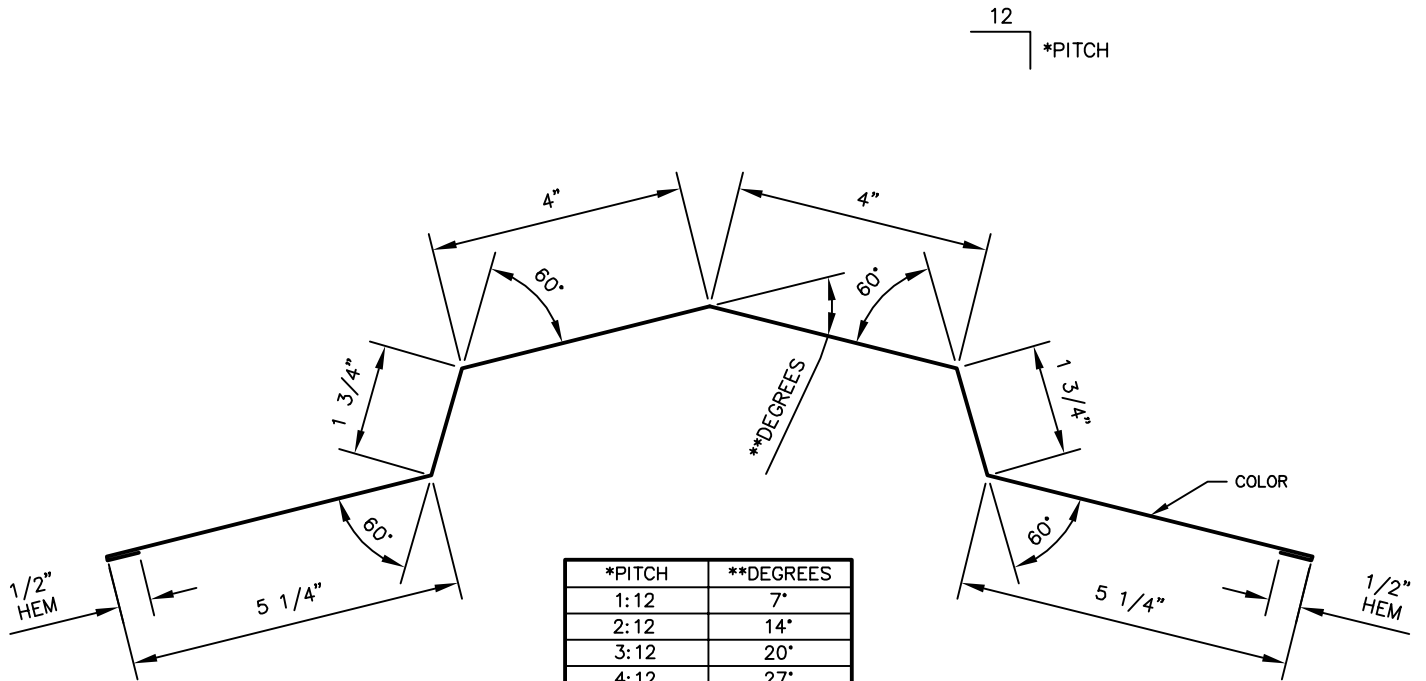

FLOATING HIP TRIM

PANEL PROFILES	GAUGE
138T	24
238T	24
MAXIMA 2"	24
MAXIMA 2" ADV	24
MAXIMA 2" ADV w/o SHOULDERS	24

GIRTH: 23"
BENDS: AS SPECIFIED

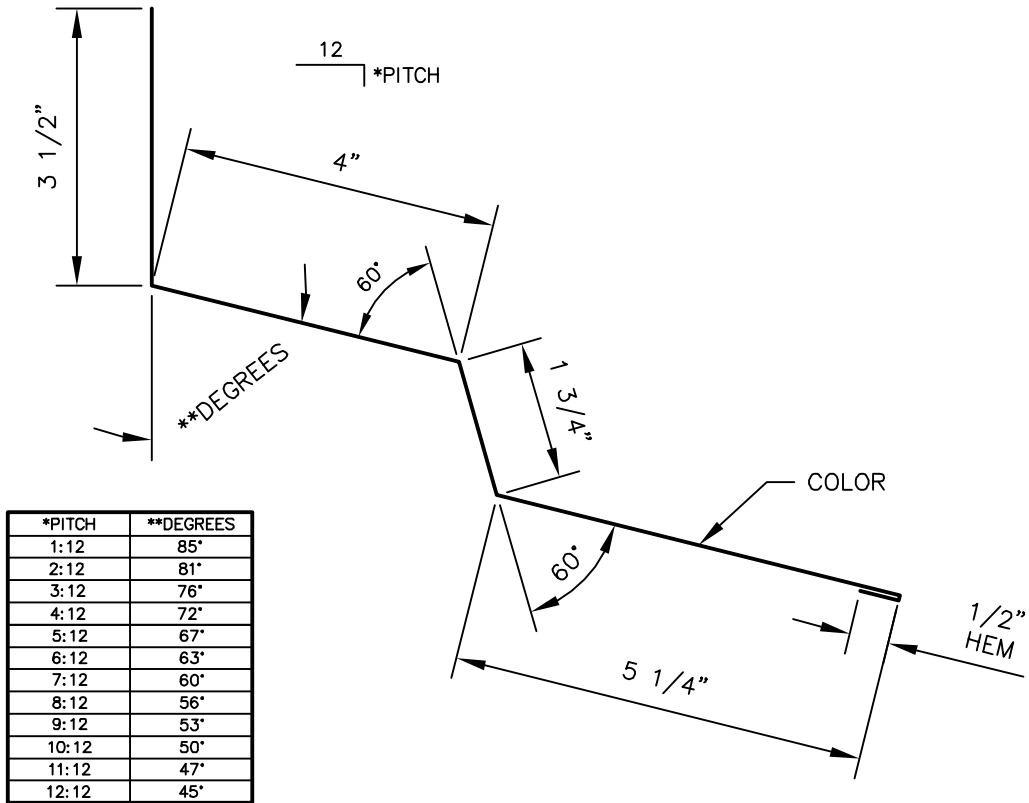

FLOATING HEADWALL TRIM

PANEL PROFILES	GAUGE
138T	24
238T	24
MAXIMA 2"	24
MAXIMA 2" ADV	24
MAXIMA 2" ADV w/o SHOULDERS	24

GIRTH: 15"
BENDS: AS SPECIFIED

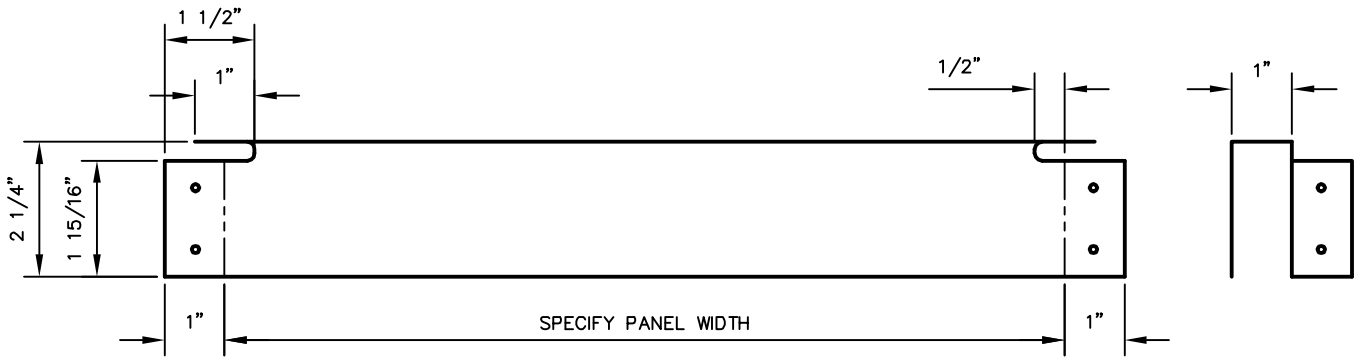

238T METAL CLOSURE @ RIDGE

(USE WITH PRE-FABRICATED FOAM INSERT)

PANEL PROFILES	GAUGE
238T	24

GIRTH: 5 1/2"
BENDS: 90°

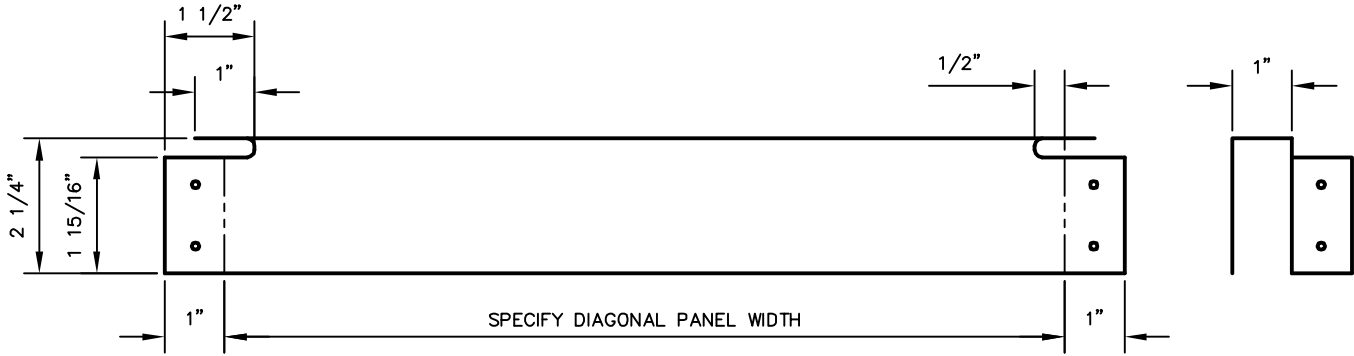

238T METAL CLOSURE @ HIP
 (USE WITH PRE-FABRICATED FOAM INSERT)

PANEL PROFILES	GAUGE
238T	24

GIRTH: 5 1/2"
 BENDS: 90°